

Expansion Joint Profiles

Expert solutions for joints

2023-24

Since 1999

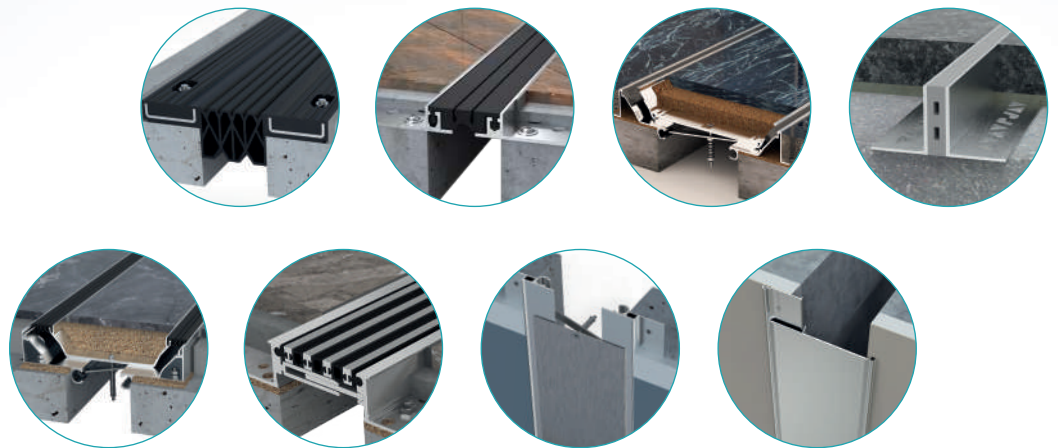

For information



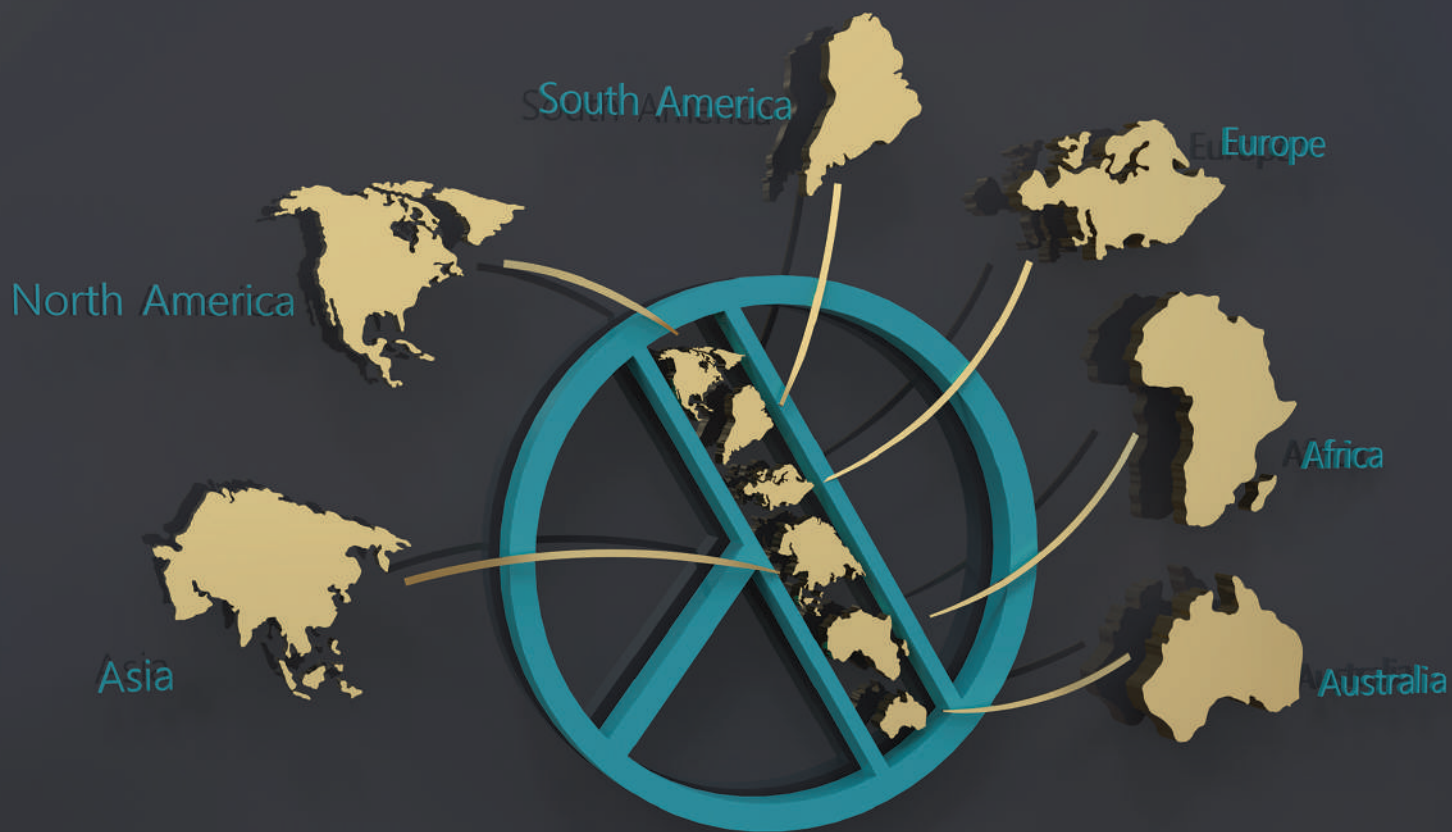

We build solutions !

waterslag and copping systems
aluminium louvres and solar shading systems
ceramic, terrazo and drywall profiles

aluminium & PVC skirting profiles

transition and elevation difference profiles

rubber & TPE wall and corner guard system

wall and corner protection systems

star nosing profiles

tangible surfaces tactile paving fire and water barriers

glass rail systems

mechanic facade systems

stainless steel protection systems

movement joint profiles

shrinkage and crack control joint products

PVC + wooden + aluminium composite deck systems

elastic PVC skirtings

expansion joint profiles

arfen adjustable door frames

entrance mat system



Arfen Köprü Yapı Teknolojileri Ltd. Şti. / İZMİT



Arfen İnşaat A.Ş. / İSTANBUL



Arfen Alüminyum A.Ş. / TEKİRDAĞ

As ARFEN, We've started our journey since 1999. We have three manufacturing factories over two continents in total of 15000 m2 closed area. We produce construction Expansion Joint Profiles, Bridge Expansion Joint Profiles, Wall and Corner Protection systems, Decoration Profiles and Entrance mat systems for our country and the World. ARFEN is able to meet the World standards and requirements of the sector. We are keen and eager on continuously developing and growing with our valuable business partners.

CONTENTS

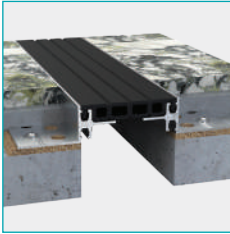

GASKETED FLOOR, WALL, CEILING PROFILES

Economic Expansion Joint Profiles- suitable for pedestrian load and light vehicle loads.

PAGE
07-25

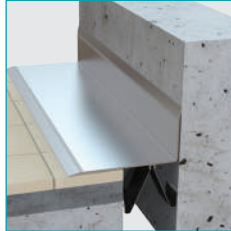

FLOOR, WALL, CEILING COVER PROFILES

One sided screwed or steel spring Expansion Joint Profiles are used in applications for gross concrete walls or ceilings.

PAGE
26-29

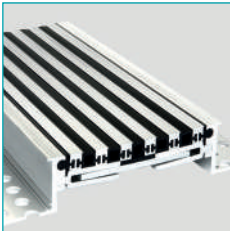

300 SERIES FLOOR, WALL AND CEILING PROFILES

Composition of Aluminium profiles and TPE inserted Expansion Joint Profiles are suitable for shopping centres, light industrial structures, warehouses, hospitals, airports and metro stations. Suitable to places where subjected light to medium vehicle load and intense pedestrian load.

PAGE
30-37

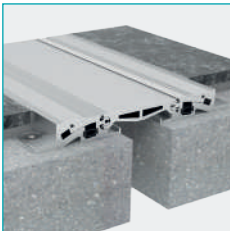

HEAVY DUTY HYGIENIC EXPANSION JOINT PROFILES

ARFEN 700 and 800 series of Expansion Joint Profiles and Sinus type floor profiles are resistant to heavy loads. They are perfectly performed at shopping malls, hospitals, industrial buildings and etc. with their hygienic and decorative structures.

PAGE
38-49

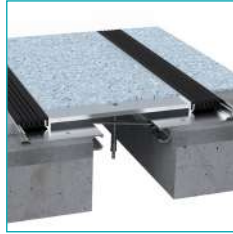
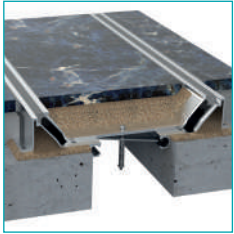

SEISMIC FLOOR, WALL AND CEILING PROFILES

Seismic Expansion Joint Profiles have high movement capacity and can easily be applied to large gaps. Suitable for many types of floor coverings.

PAGE
50-69

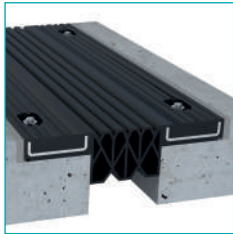
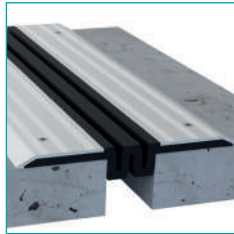

CARPARK EXPANSION JOINT PROFILES

Composition of rubber, steel and aluminium carpark Expansion Joint Profiles are sound dampen (silent) and ideal for carpark projects.

PAGE
70-77

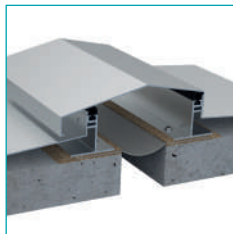

COMPLETE WATERTIGHT EXPANSION JOINT PROFILES

These Expansion Joint Profiles are used in wet areas, terraces and open carparks where subjected to water. They are easily used with isolation materials.

PAGE
78-95

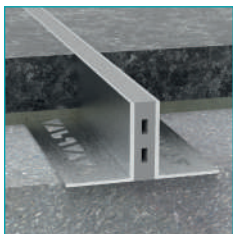
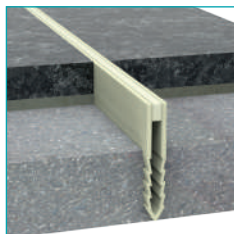

MOVEMENT JOINT PROFILES

Movement joint profiles are designed to avoid cracks in ceramic or granite floors because of expansion due to hot weather. They can be used for both internal and external areas.

PAGE
96-101

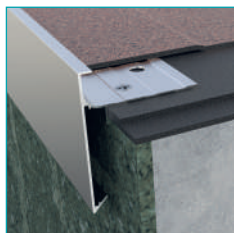

INSULATION FLASHING AND COPING SYSTEMS

insulation flashing and coping systems are used at the end points of waterproofing applications.

PAGE
102-107

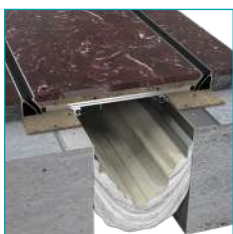

FIRE AND WATER BARRIERS

Different type of HYDROFLEX and FIRE BARRIERS designed to stop the water and fire in Expansion Joint Profile areas.

PAGE
108-118

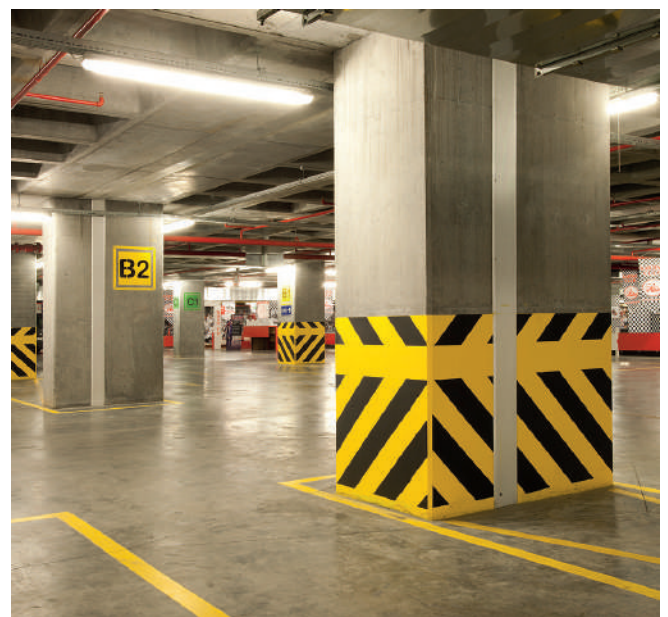



AR 200DT
Wall Ceiling Cover
Expansion Joint Profiles

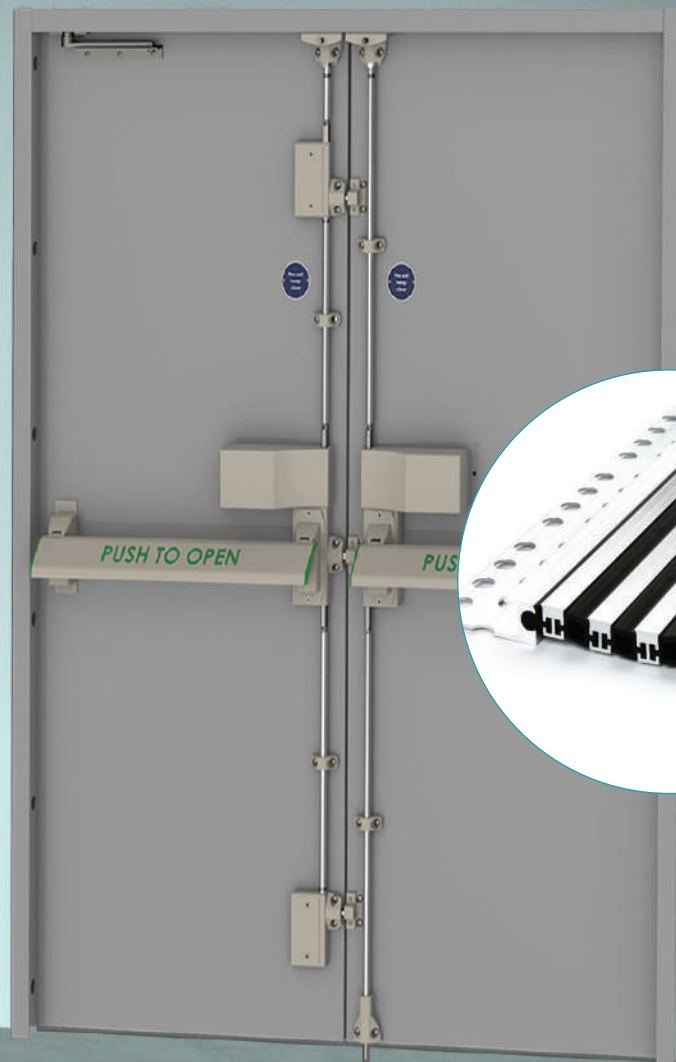

AR 211-100
Flush Mounted
Wall And Ceiling Profiles

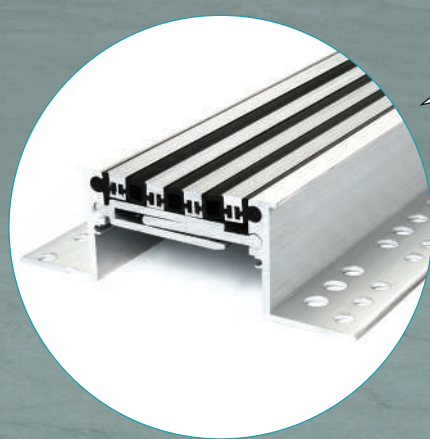
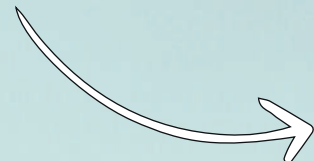
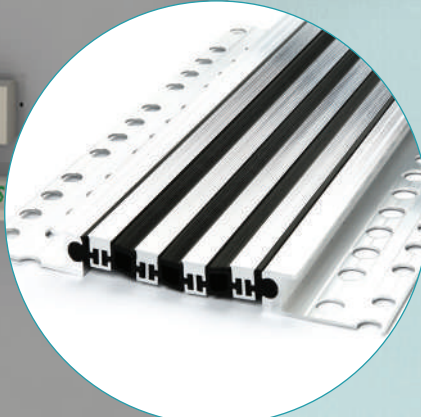

AR 303-100
Flush Mounted Floor
Expansion Joint Profiles

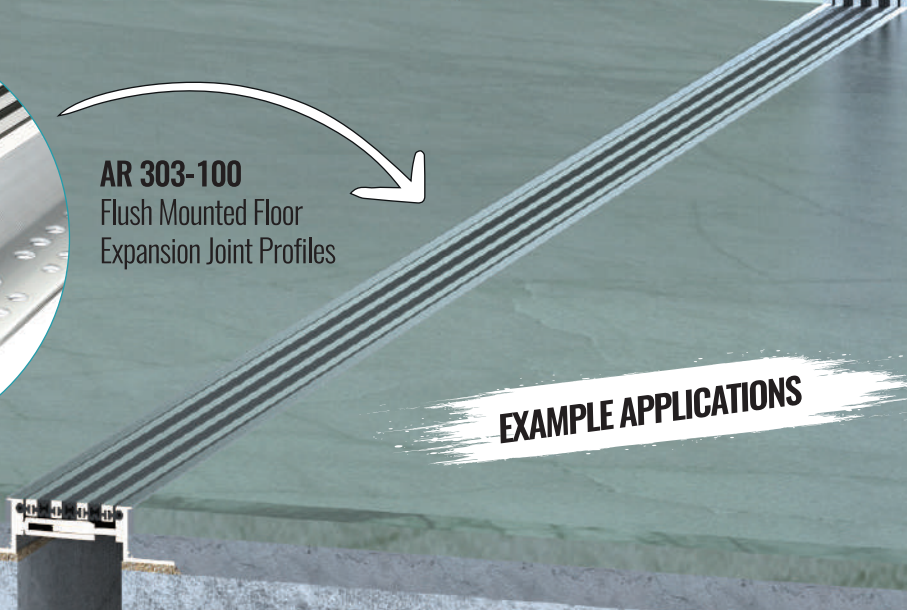
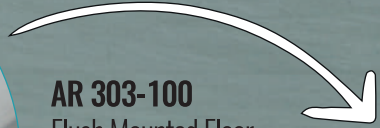

EXAMPLE APPLICATIONS

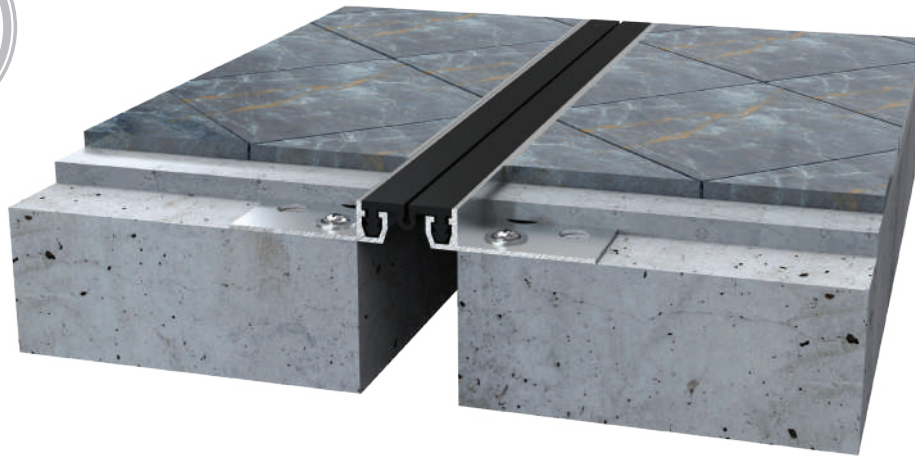

» AR100-030

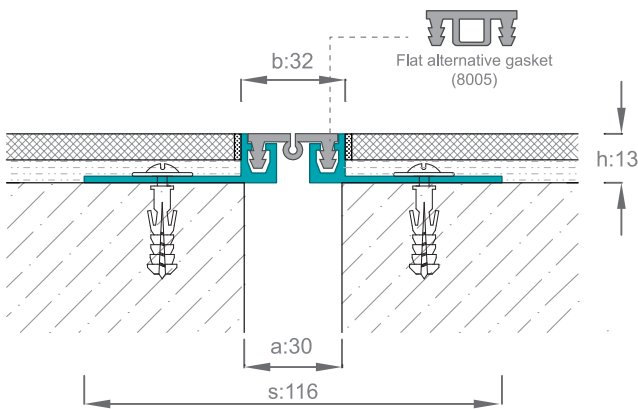

» AR100-030K

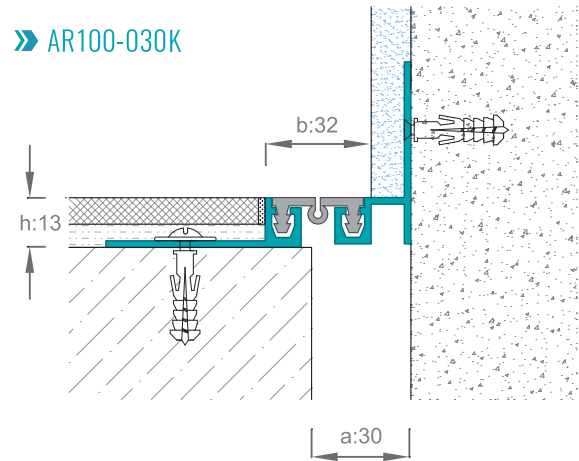

» AR102-030

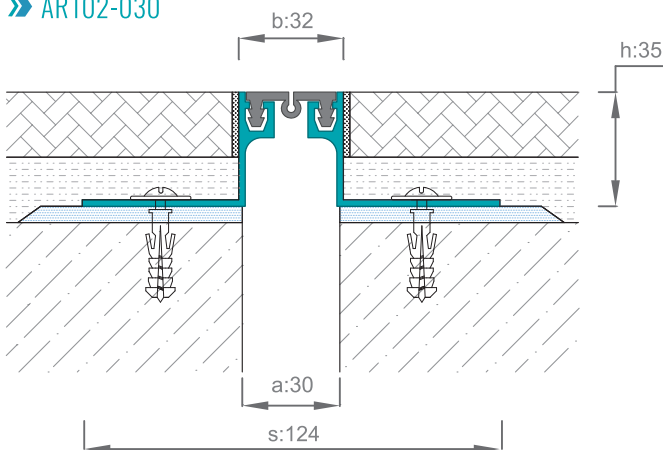

» AR120-030

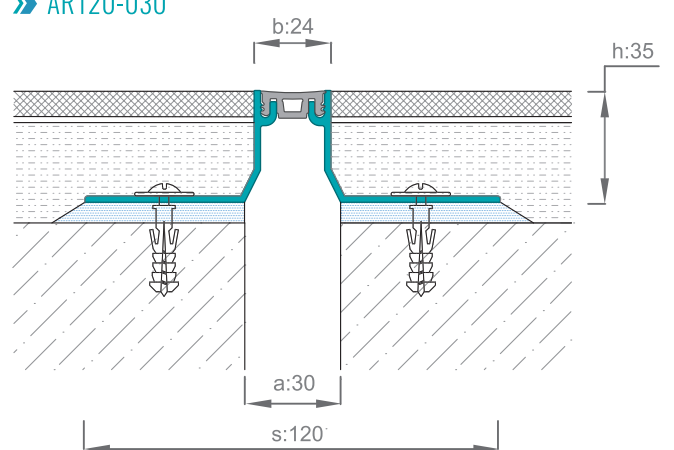

GASKET COLOURS



Middle gasketed Under Finish floor Expansion Joint Profiles are suitable for 30 mm gaps. Can be used in different levels of floor coverings such as ceramic, granite, mosaic and screed. Usually applied to pedestrian load and light vehicle load (not intense) areas. (h: 26 mm and above). Mounted to floor from both sides by having 35 cm spacing with appropriate anchors and screws. Smooth gasket alternative should be used in hygienic areas.



PRODUCT CODE	DESCRIPTION	JOINT WIDTH (a) mm	VISIBLE SURFACE (b) mm	PROFILE HEIGHT (h) mm	TOTAL WIDTH (s) mm	SURFACE	MOVEMENT CAPACITY mm	LOAD CAPACITY
AR 100 - 030	Used in Ceramic, Suitable 8-10 mm	30	32	13	116	Mill Finish Alu.+TPE	±10	Pedestrian Load
AR 100 - 031	Used in Ceramic, Suitable 12-14 mm	30	32	20	100	Mill Finish Alu.+TPE	±10	Pedestrian Load
AR 101 - 030	Suitable for Natural Granite, Marble and etc.	30	32	26	116	Mill Finish Alu.+TPE	±10	Pedestrian Load Light
AR 102 - 030	Suitable for Granite, Marble and etc.	30	32	35	124	Mill Finish Alu.+TPE	±10	Pedestrian Load Light
AR 103 - 030	Suitable for Industrial floors, granite and etc.	30	32	50	124	Mill Finish Alu.+TPE	±10	Pedestrian Load Light
AR 120 - 030	Suitable for Ceramic, Marble and etc	30	24	35	120	Mill Finish Alu.+TPE	±5	Pedestrian Load



» AR105-050

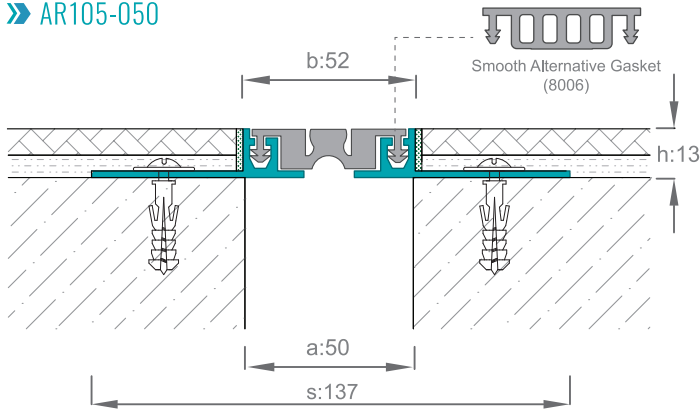

» AR105-050K

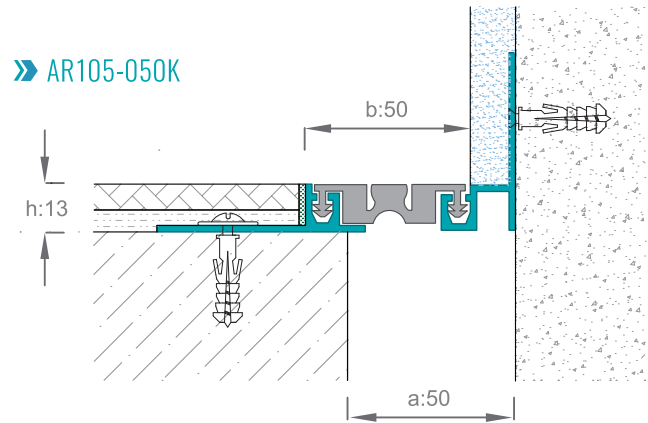

» AR107-050

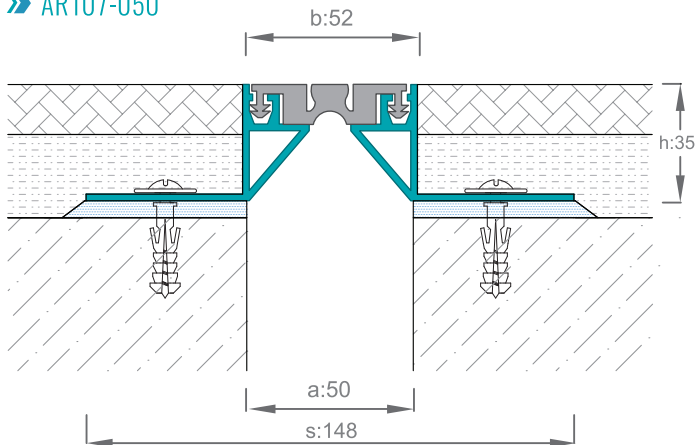

» AR109-050

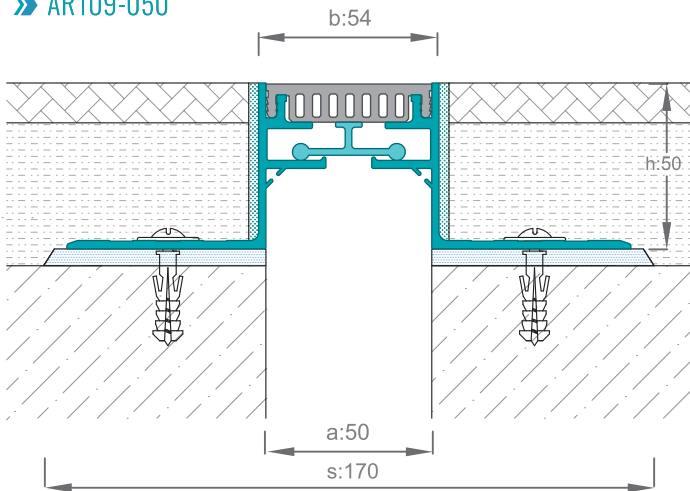

GASKET COLOURS

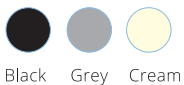

Gasketed Under Finish floor Expansion Joint Profiles are suitable for 50 mm gaps. Can be used in all floor covers at different heights. Smooth gasket alternative is also available. Mounted to floor from both sides by having 35 cm spacing with appropriate anchors and screws.



PRODUCT CODE	DESCRIPTION	JOINT WIDTH (a) mm	VISIBLE SURFACE (b) mm	PROFILE HEIGHT (h) mm	TOTAL WIDTH (s) mm	SURFACE	MOVEMENT CAPACITY mm	LOAD CAPACITY
AR 105 - 050	Suitable for 8-10 mm Ceramic	50	52	13	137	Mill Finish Alu.+TPE	±10	Pedestrian Load
AR 106 - 050	Suitable for natural granite, marble and etc.	50	52	26	136	Mill Finish Alu.+TPE	±10	2.5 Ton
AR 107 - 050	Suitable for natural granite, marble, screed and etc.	50	52	35	148	Mill Finish Alu.+TPE	±10	2.5 Ton 2 Ton
AR 107 - 051	Suitable for natural granite, marble, and etc.(Economic)	50	52	35	134	Mill Finish Alu.+TPE	±10	Pedestrian Load
AR 107 - 052	Suitable with PVC floor coverings	50	60	35	146	Mill Finish Alu.+TPE	±10	2.5 Ton 2 Ton
AR 107 - 053	Suitable for granite, marble, screed and etc.	50	52	50	148	Mill Finish Alu.+TPE	±10	2.5 Ton
AR 107 - 054	Suitable for granite, marble, screed and etc.	50	52	50	149	Mill Finish Alu.+TPE	±10	2.5 Ton 2 Ton
AR 109-050	Suitable for granite, marble, screed and etc.(Flat surface)	50	54	50	170	Mill Finish Alu.+TPE	±10	Pedestrian Load

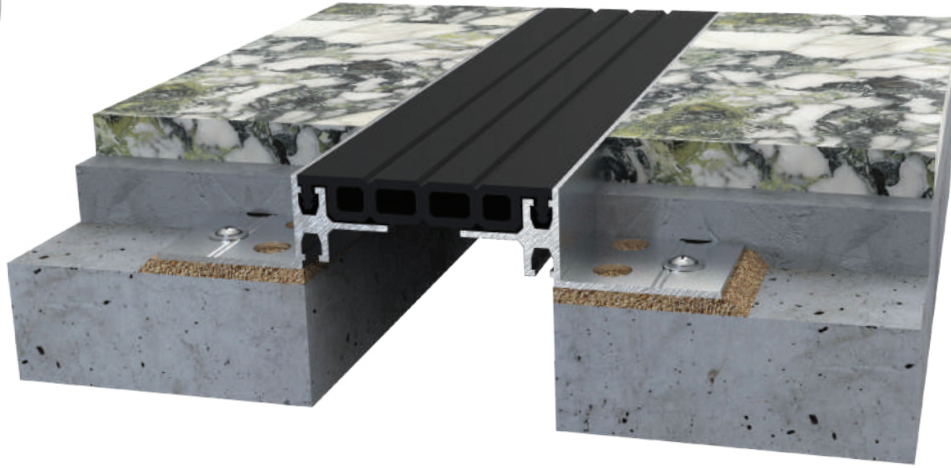

» AR106-080

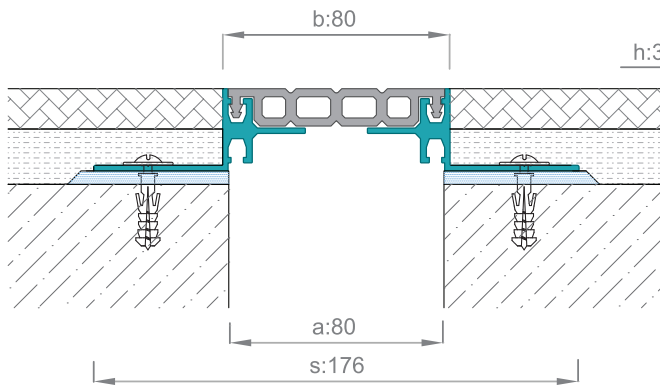

» AR106-080K

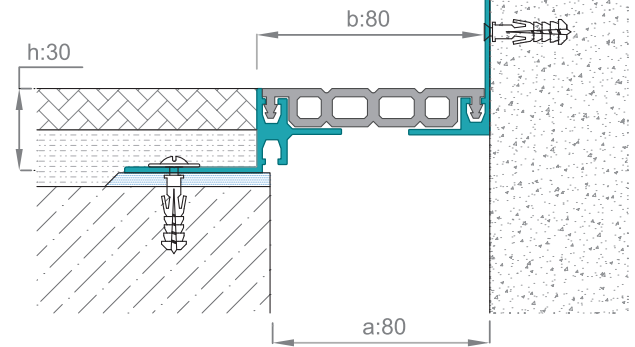

» AR109-080

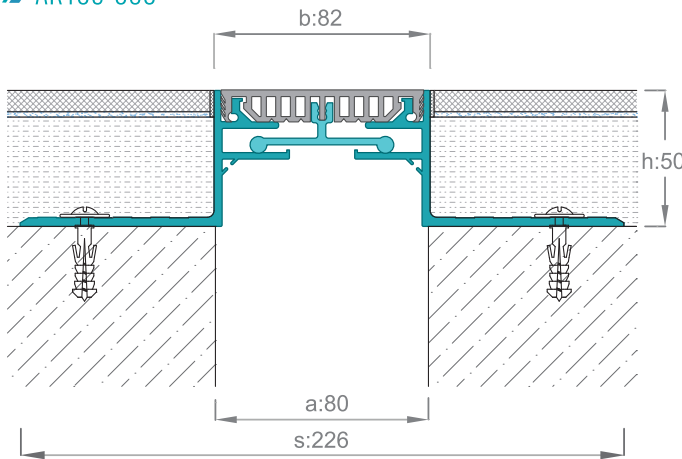

» AR109-081

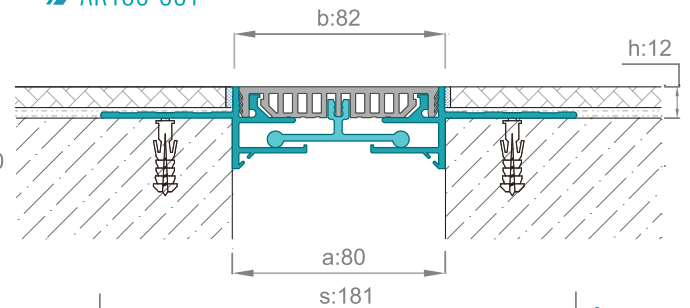

GASKET COLOURS



Under finish Expansion Joint Profiles suitable for 80 mm gaps. Utilized in areas where subjected to pedestrian load.

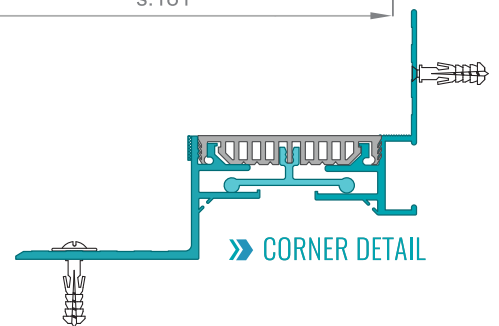

PRODUCT CODE	DESCRIPTION	JOINT WIDTH (a) mm	VISIBLE SURFACE (b) mm	PROFILE HEIGHT (h) mm	TOTAL WIDTH (s) mm	SURFACE	MOVEMENT CAPACITY mm	LOAD CAPACITY
AR 106-080	Suitable for Flat top surface, granite, marble and etc	80	80	30	176	Mill Finish Alu.+TPE	±10	Pedestrian Load
AR 109-080	Suitable for decorative, hygienic coverings	80	82	50	226	Mill Finish Alu.+TPE	±10	Pedestrian Load
AR 109-081	Suitable for 8 to 10 mm coverings	80	82	12	181	Mill Finish Alu.+TPE	±10	Pedestrian Load
AR 106-100	Suitable for ceramic, marble and etc.	100	100	30	200	Mill Finish Alu.+TPE	±15	Pedestrian Load
AR 106-101	Suitable for ceramic, marble and etc.	100	100	60	200	Mill Finish Alu.+TPE	±15	Pedestrian Load
AR 734-100	Suitable for open-closed carpark, screed asphalt and etc	100	150	50	240	Mill Finish Alu.+TPE	±50	30 Ton



» AR106-100

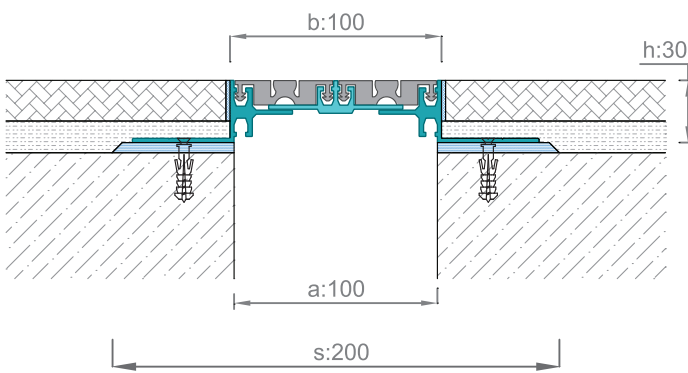

» AR106-100K

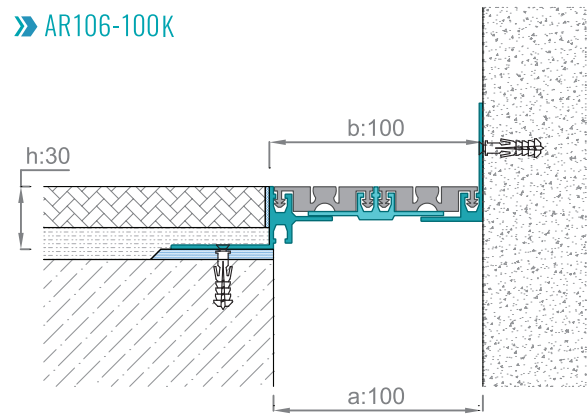

» AR734-100

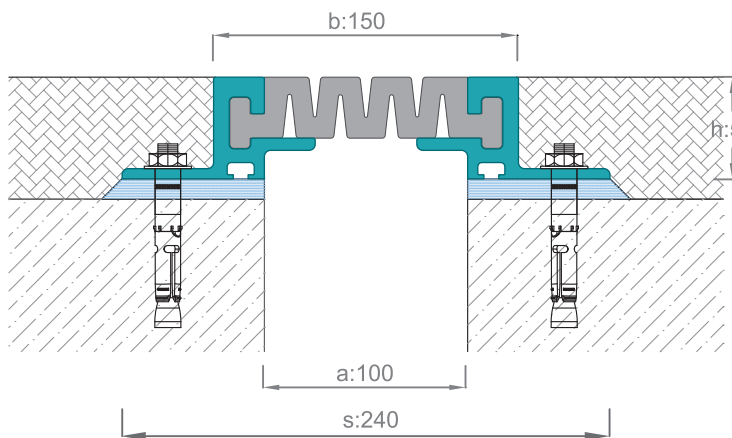

» AR734-100K

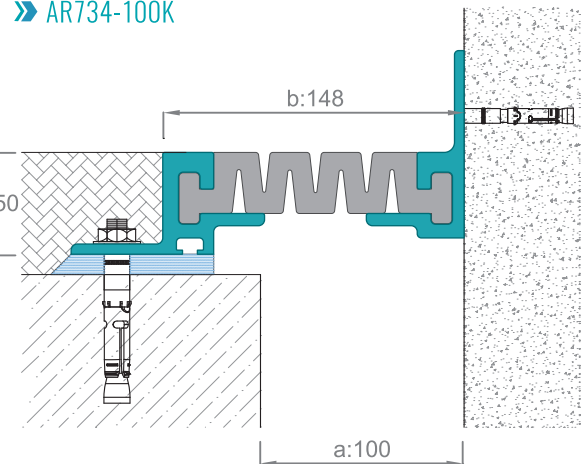

GASKET COLOURS

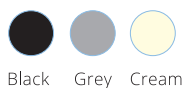

Under finish Expansion Joint Profiles with special gasket are used for 100 mm gap. Usable for different levels in ceramic, granite, mosaic and screed type floor covers. AR-734-100 is suitable for vehicle load. Can also be used in Carpark applications.





» AR152-030

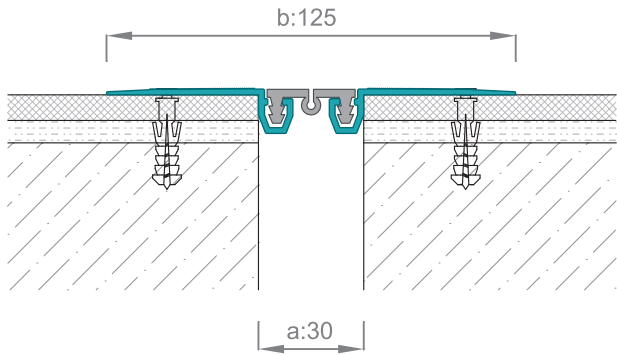

» AR152-030K

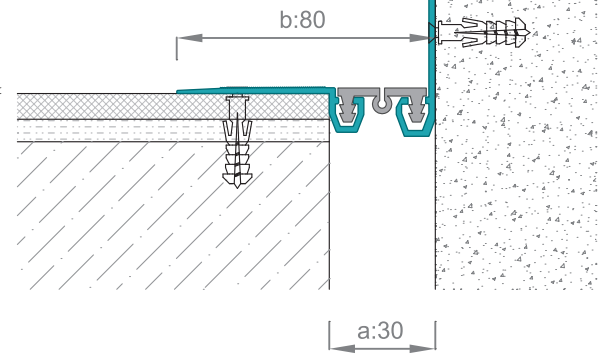

» AR150-030

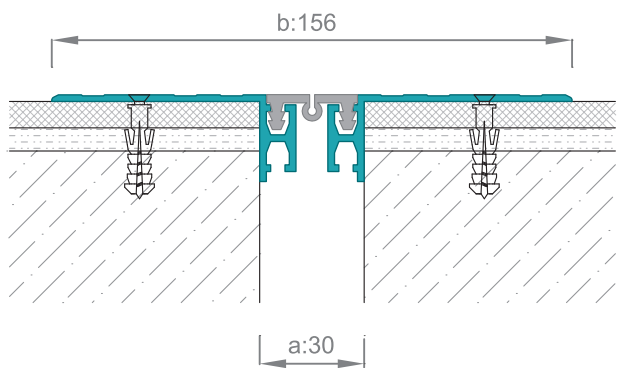

» AR154-030

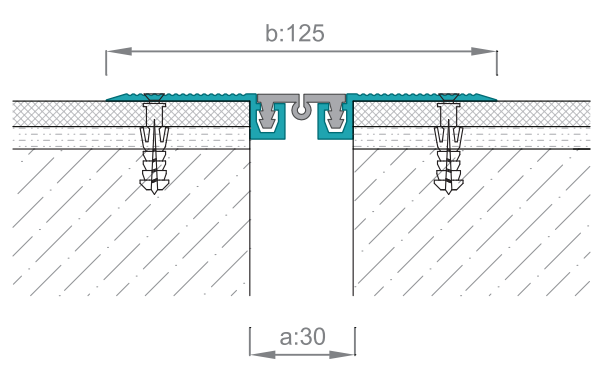

GASKET COLOURS

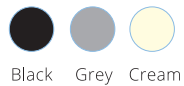

Over finish Expansion Joint Profiles with special gasket are used for 30 mm gap. Mounted to the both sides of the floor with intervals of 35 cm. Generally, suitable for pedestrians and light vehicle load.



APPLICATIONS

PRODUCT CODE	DESCRIPTION	JOINT WIDTH (a) mm	VISIBLE SURFACE (b) mm	PROFILE HEIGHT (h) mm	TOTAL WIDTH (s) mm	SURFACE	MOVEMENT CAPACITY mm	LOAD CAPACITY
AR 150-030	Anodised decorative and wide	30	156	24	156	Anodised Alu.+TPE	±10	Pedestrian Load Light
AR 152-030	Anodised screw holed, decorative and narrow	30	125	12	125	Anodised Alu.+TPE	±10	Pedestrian Load
AR 154-030	Not anodised floor profile	30	125	12	125	Mill Finish Alu.+TPE	±10	Pedestrian Load

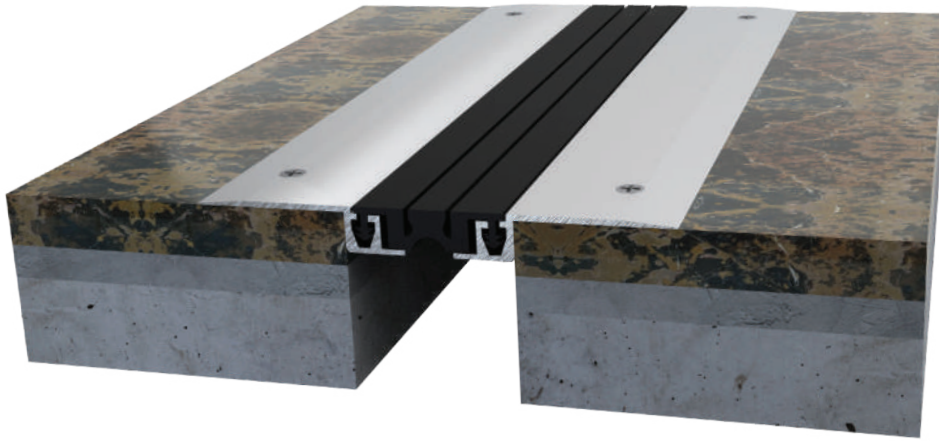

» AR153-050

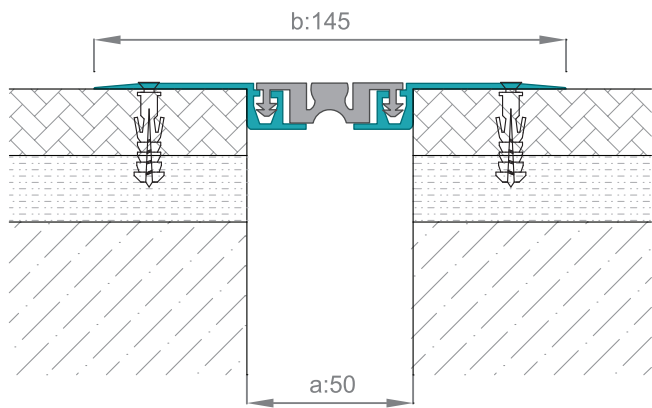

» AR153-050 K

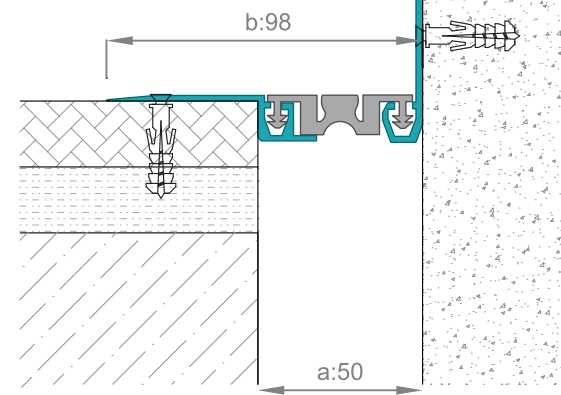

» AR151-050

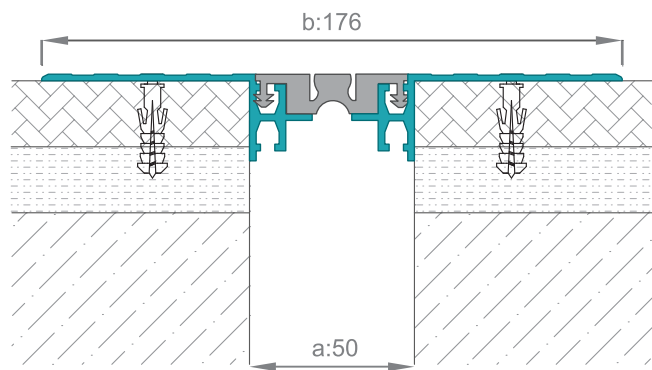

» AR154-050

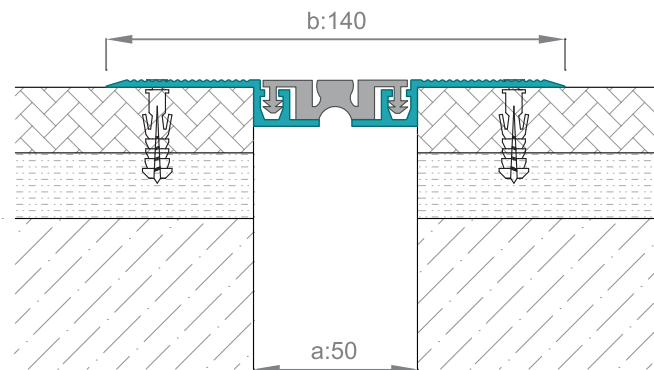

GASKET COLOURS



Over finish Expansion Joint Profiles with special gaskets are used for 50 mm gap. Generally, suitable for pedestrians and light vehicle load.



PRODUCT CODE	DESCRIPTION	JOINT WIDTH (a) mm	VISIBLE SURFACE (b) mm	PROFILE HEIGHT (h) mm	TOTAL WIDTH (s) mm	SURFACE	MOVEMENT CAPACITY mm	LOAD CAPACITY
AR 151 - 050	Anodised and wide top surfaced.	50	176	24	176	Anodised Alu.+TPE	±10	Pedestrian Load Light Vehicle
AR 151 - 051	Anodised and wide top surfaced(Economic)	50	176	12	176	Anodised Alu.+TPE	±10	Pedestrian Load
AR 153 - 050	Anodised, decorative and screw holed.	50	145	12	145	Anodised Alu.+TPE	±10	Pedestrian Load
AR 154 - 050	Not anodised floor profile	50	140	12	140	Mill Finish Alu.+TPE	±10	Pedestrian Load

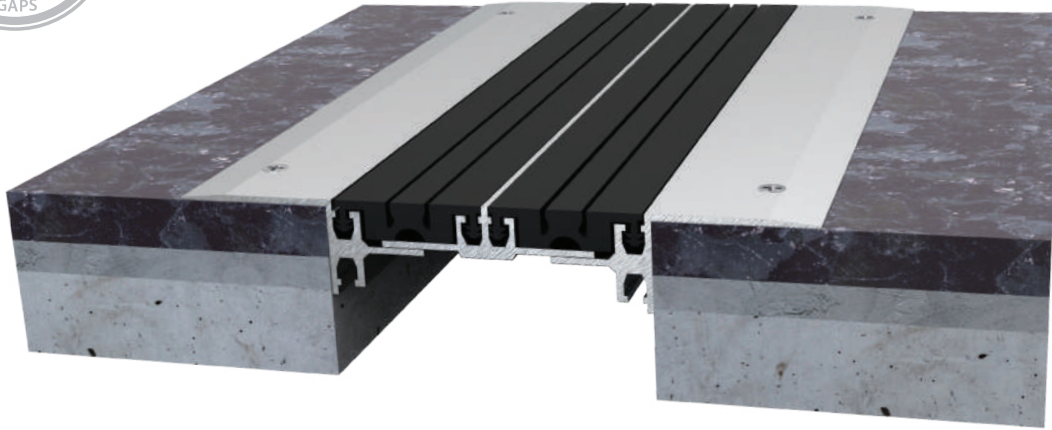

» AR153-080

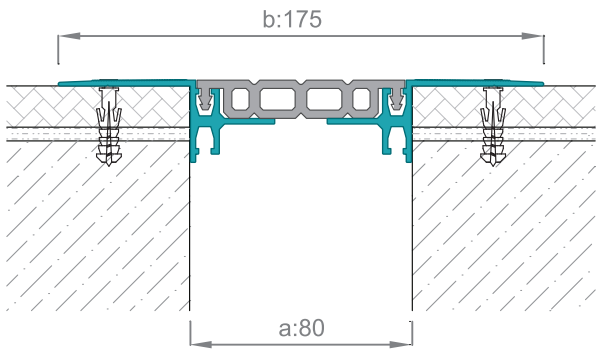

» AR153-100

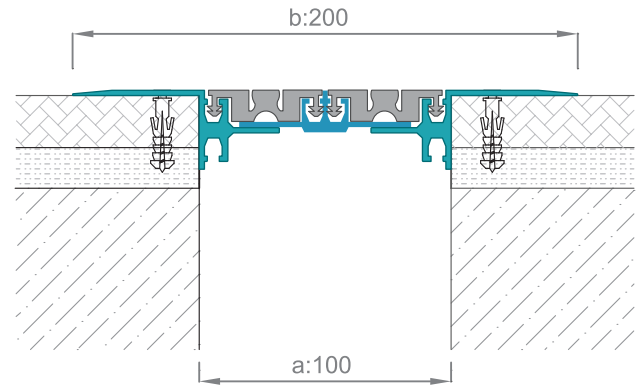

» AR191-100

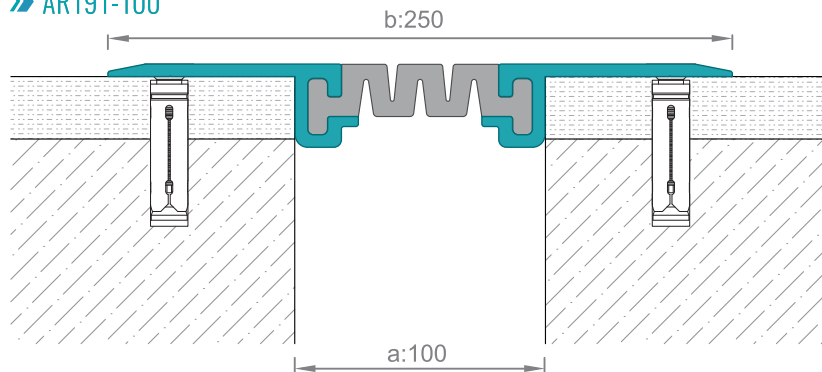

GASKET COLOURS



Over finish Expansion Joint Profiles with special gasket are used for 80 mm or 100 mm gap. AR 153-080 and AR 153-100 is more suitable on applications for ceramic, granite and marble floor covers. AR 191-100 is used for Car Park applications for screed and asphalt. Mounted to the floor by both sides with a help of appropriate anchor.

APPLICATIONS



PRODUCT CODE	DESCRIPTION	JOINT WIDTH (a) mm	VISIBLE SURFACE (b) mm	PROFILE HEIGHT (h) mm	TOTAL WIDTH (s) mm	SURFACE	MOVEMENT CAPACITY mm	LOAD CAPACITY
AR 153 - 080	Over Finish, Anodised and screw holed	80	175	28	175	Anodised Alu.+TPE	±10	Pedestrian Load
AR 153 - 100	Over Finish, Anodised and screw holed	100	200	28	200	Anodised Alu.+TPE	±15	Pedestrian Load
AR 191 - 100	Special for carpark floor.	100	250	28	250	Mill Finish Alu.+TPE	±25	30 Ton
AR 191 - 150	Special for carpark floor.	150	300	35	300	Mill Finish Alu.+TPE	±50	16 Ton

WHY DILATATION HAS BEEN CREATED !

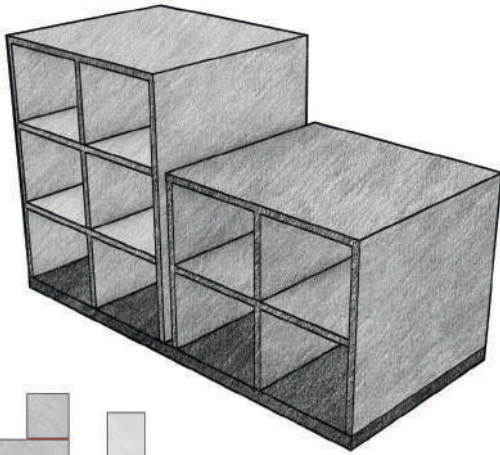

PLAN

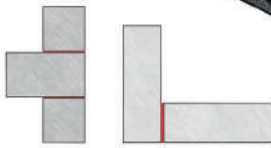

Structures exposed to Thermal expansions.
Horizontally and vertically unsymmetrical structures.

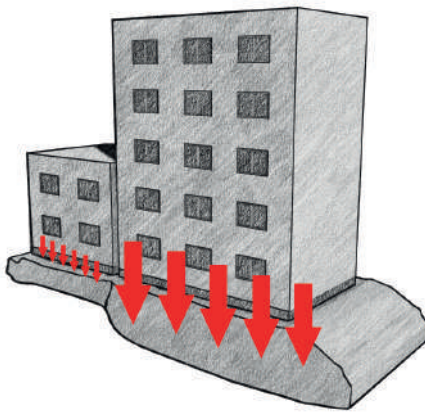

Structures under different floor types and loads.

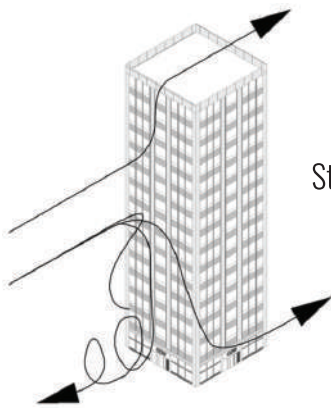

Structures exposed to wind loads

Earthquake Movements

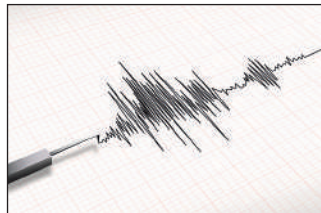

ARFEN APPLICATIONS

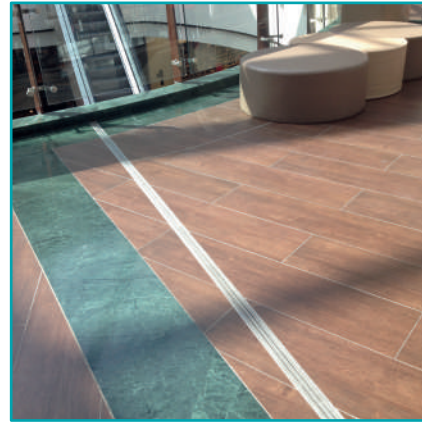

AR 107 SERIES



AR 153 SERIES



AR 106 SERIES



AR 191 SERIES

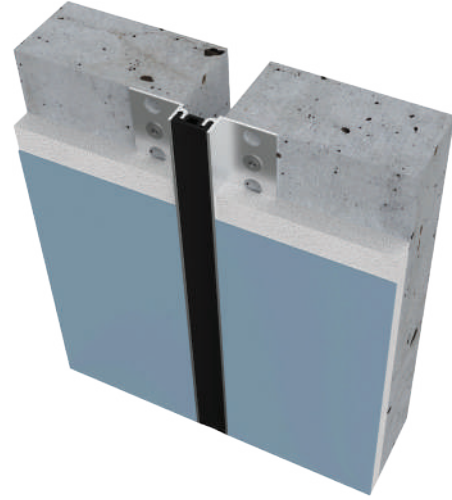

» AR200-030

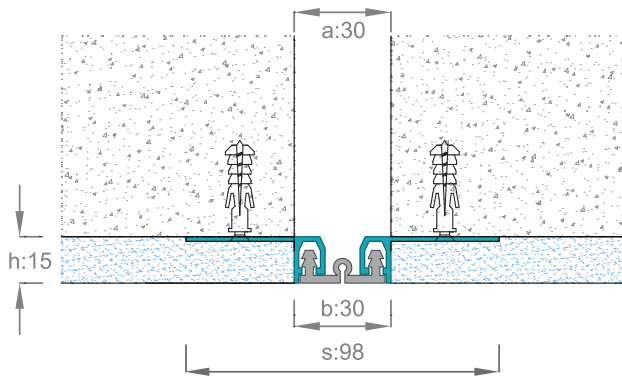

» AR200-030K

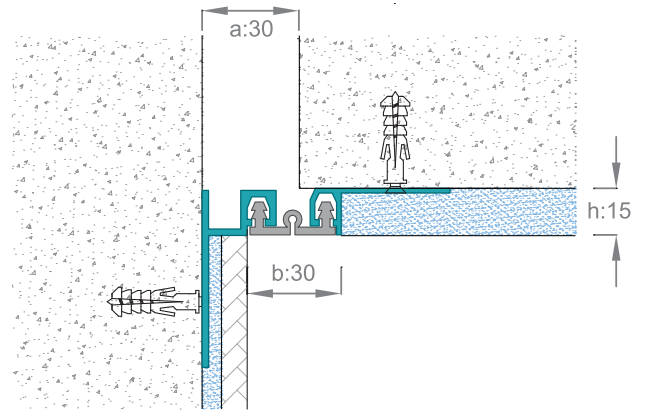

» AR221-030

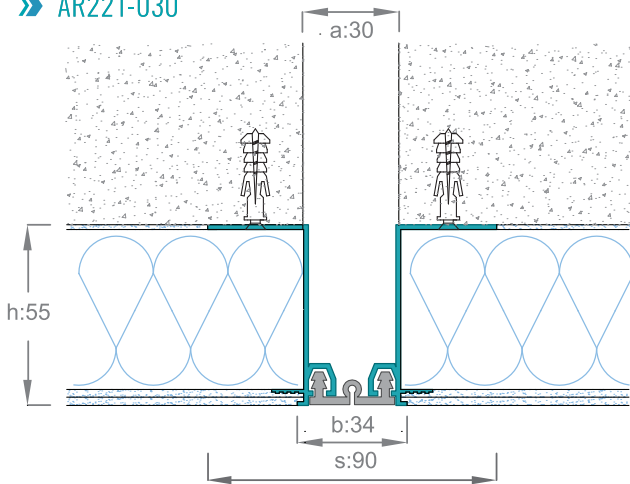

» AR220-031

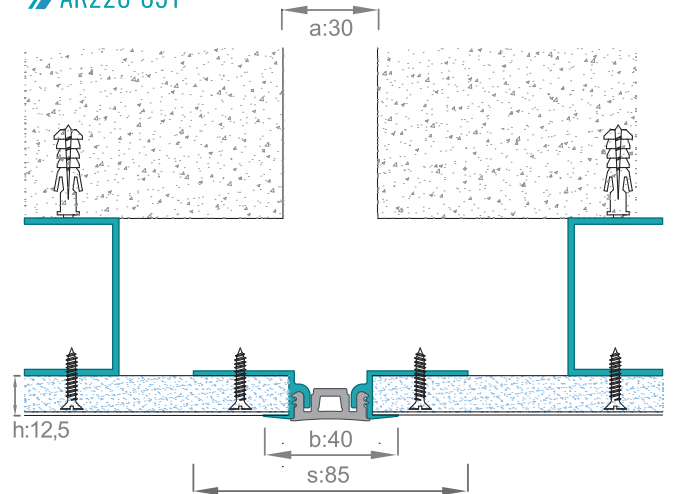

GASKET COLOURS

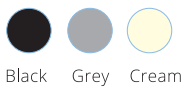

30 mm Wall Expansion Joint Profiles are suitable for small gaps and thermal movements. Gaskets on the Expansion Joint Profiles can be removed and changed easily. These profiles are more compatible with floor profiles. Suitable to plaster, drywall, ceramic and thermal insulation boards with 30 mm insert.



PRODUCT CODE	DESCRIPTION	JOINT WIDTH (a) mm	VISIBLE SURFACE (b) mm	PROFILE HEIGHT (h) mm	TOTAL WIDTH (s) mm	SURFACE	MOVEMENT CAPACITY mm
AR 200 - 030	Suitable for 12 mm Plaster, Ceramic, Drywall	30	30	15	98	Mill Finish Alu.+TPE	±10
AR 200 - 031	Suitable for 14-18 mm Plaster, Ceramic, Drywall	30	30	20	100	Mill Finish Alu.+TPE	±10
AR 220 - 030	Narrowed gasketed plaster, drywall and etc.	30	24	12,5	90	Mill Finish Alu.+TPE	±5
AR 220 - 031	Suitable to suspended ceiling and anodised profiles for drywall and etc.	30	40	12,5	85	Anodised Alu.+TPE	±5
AR 221 - 030	Suitable to facade and heat insulation materials.	30	34	50+5	90	Mill Finish Alu.+TPE	±10

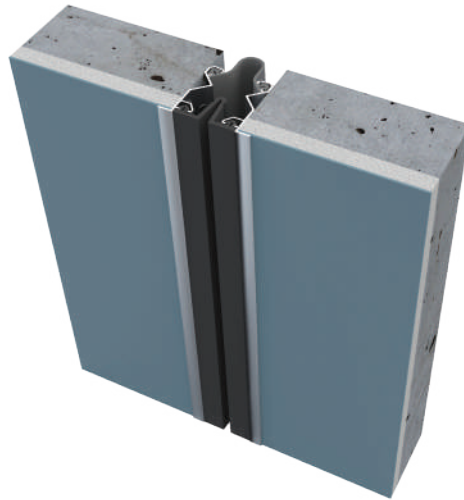
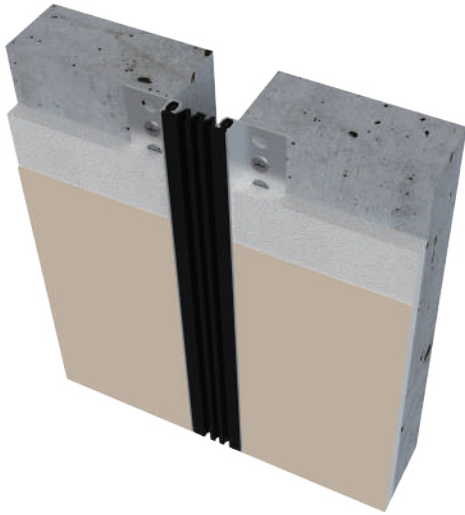

» AR202-050

» AR202-050 K

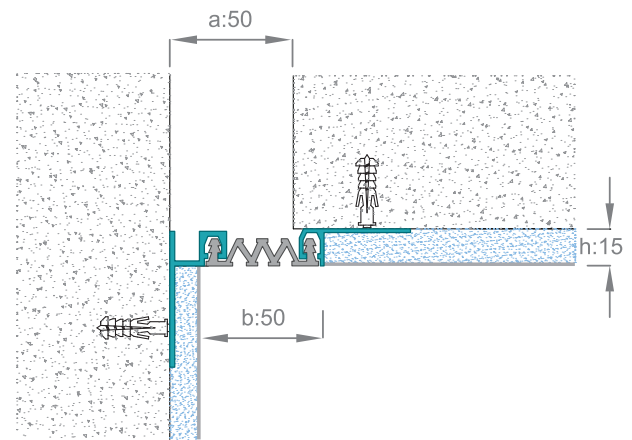
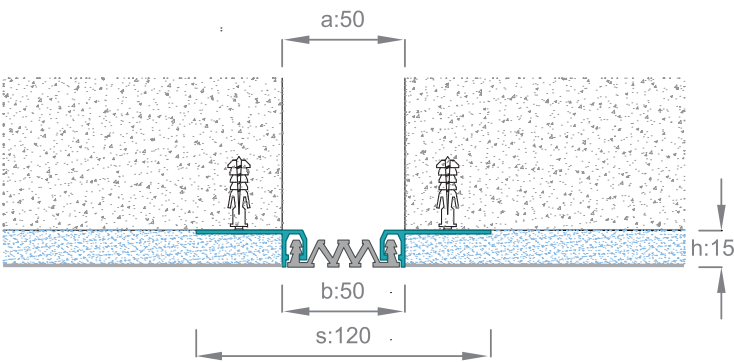

» AR221-050

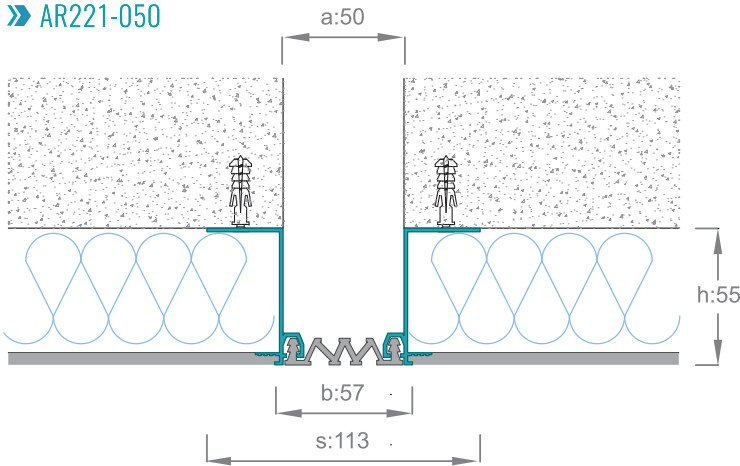

» AR285-050

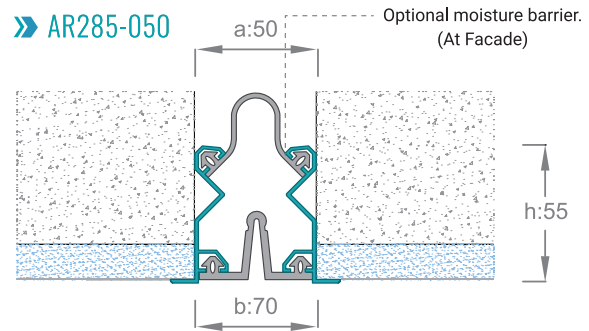

GASKET COLOURS

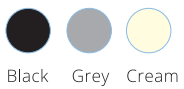

These Expansion Joint profiles suitable for 50 mm gap and used on appropriate plaster, ceramic, drywall and thermal isolation boards. Each design has corner profile option and different foot length.

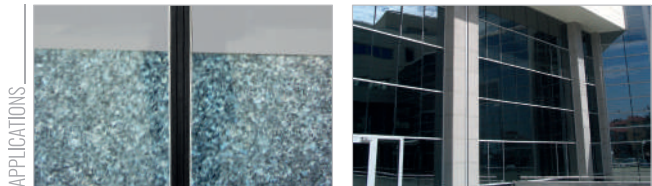

PRODUCT CODE	DESCRIPTION	JOINT WIDTH (a) mm	VISIBLE SURFACE (b) mm	PROFILE HEIGHT (h) mm	TOTAL WIDTH (s) mm	SURFACE	MOVEMENT CAPACITY mm
AR 202 - 050	Suitable for ceramic, drywall and etc. / wall gasketed	50	50	15	120	Mill Finish Alu.+TPE	±20
AR 202 - 051	Suitable for ceramic, drywall and etc. / floor gasketed	50	50	15	120	Mill Finish Alu.+TPE	±10
AR 203 - 050	Suitable for 14-18mm screed and ceramic	50	50	20	120	Mill Finish Alu.+TPE	±20
AR 221 - 050	Suitable for heat insulations and facade and etc.	50	57	50+5	113	Mill Finish Alu.+TPE	±20
AR 285 - 050	Suitable (Seismic) for internal and facade areas	50	70	55	70	Mill Finish Alu.+TPE	±25

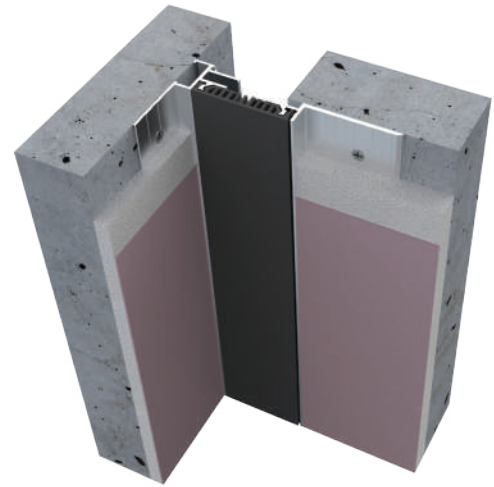
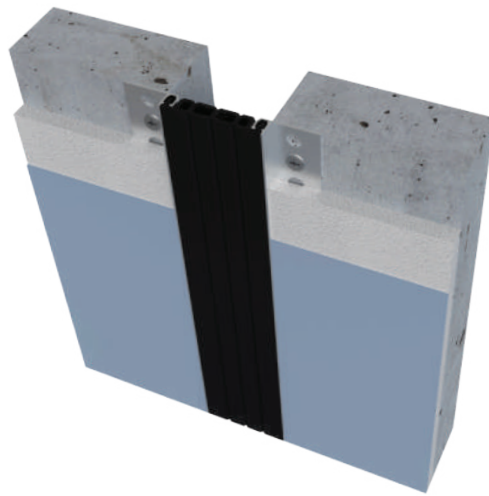

» AR202-080

» AR202-080K

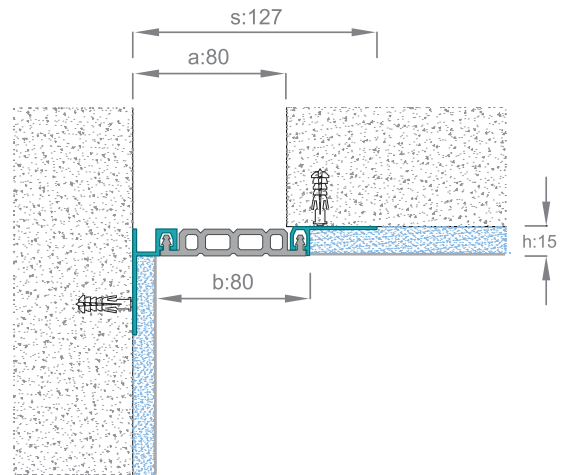
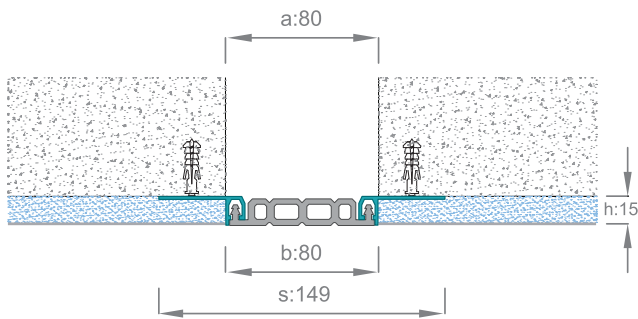

» AR215-080

» AR215-080K

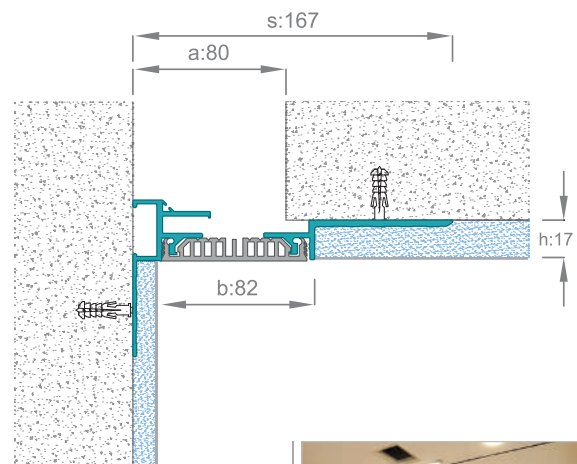
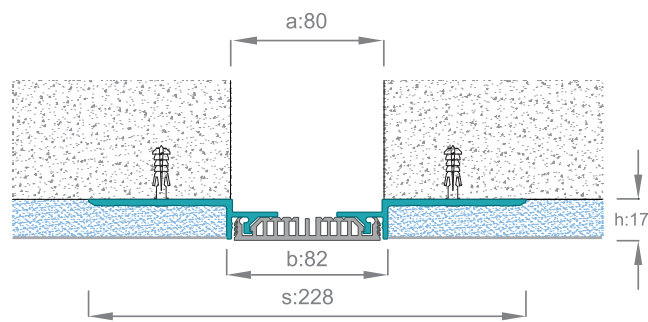

GASKET COLOURS



Suitable to similar level flooring covers with elastomeric middle gaskets. (Shown in page 9). Under finish Expansion Joint Profiles used for 80 mm gaps. Recommended for structures where subject to small movements.

APPLICATIONS



PRODUCT CODE	DESCRIPTION	JOINT WIDTH (a) mm	VISIBLE SURFACE (b) mm	PROFILE HEIGHT (h) mm	TOTAL WIDTH (s) mm	SURFACE	MOVEMENT CAPACITY mm
AR 202 - 080	Suitable with (AR 106-80) screed, ceramic and etc. with flat gasket detail.	80	80	15	149	Mill Finish Alu.+TPE	±10
AR 215 - 080	Suitable with (AR 109-80) screed, ceramic and etc. with flat gasket detail.	80	82	17	228	Mill Finish Alu.+TPE	±10

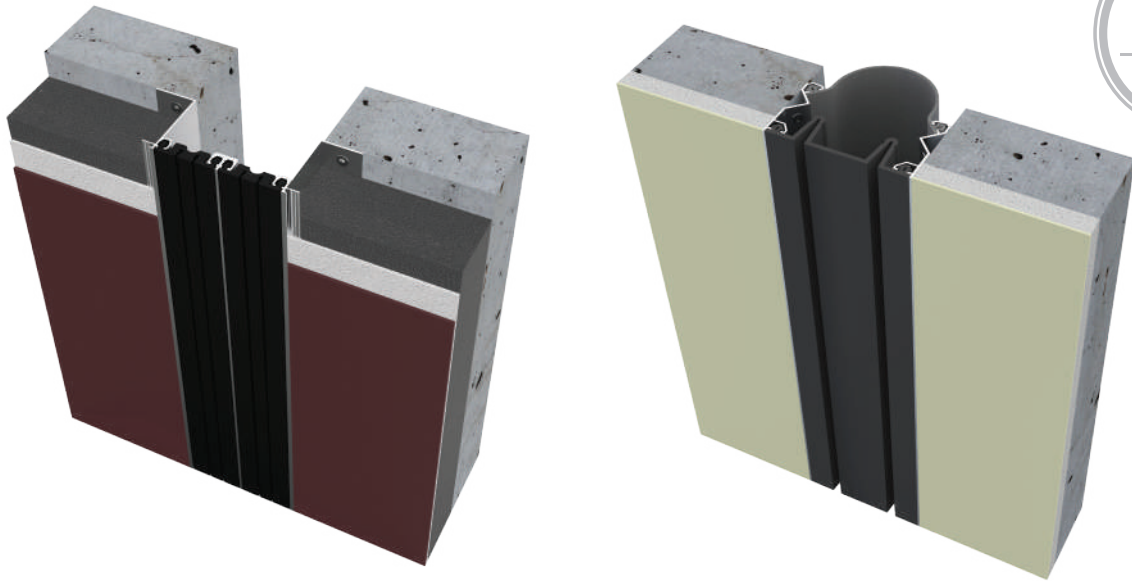

» AR202-100

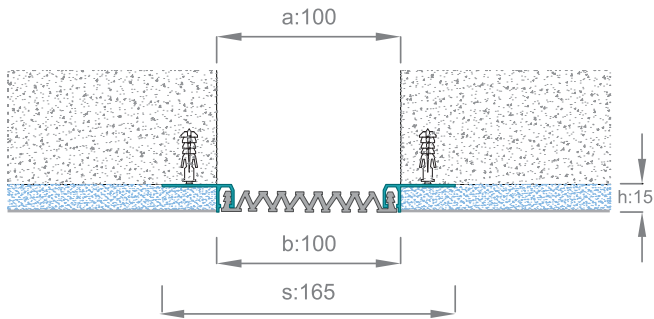

» AR202-102

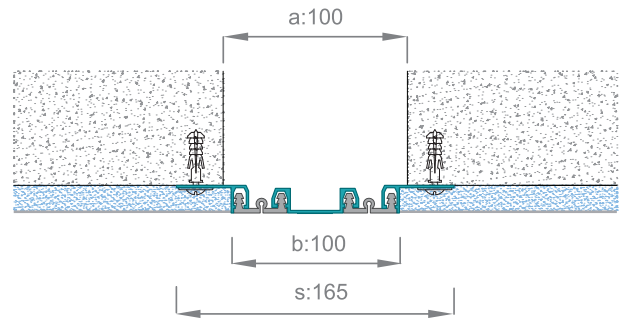

» AR221-101

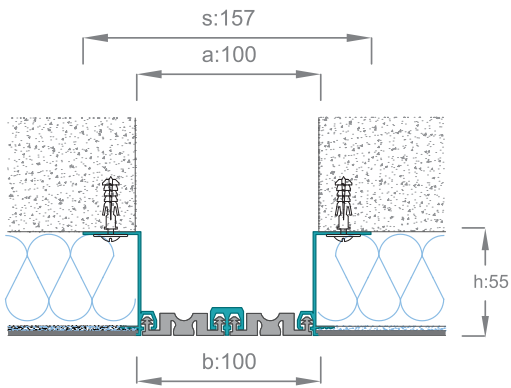

» AR285-100

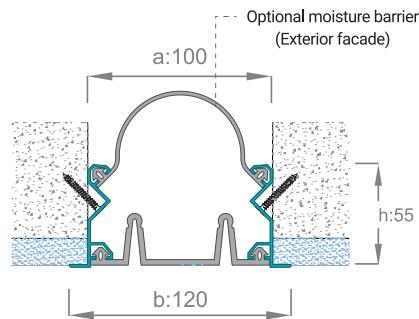

GASKET COLOURS



Expansion Joint profiles suitable for 100 mm gap with alternative gasket selections.
Used on appropriate plaster, ceramic, subjected drywall and thermal isolation boards.

PRODUCT CODE	DESCRIPTION	JOINT WIDTH (a) mm	VISIBLE SURFACE (b) mm	PROFILE HEIGHT (h) mm	TOTAL WIDTH (s) mm	SURFACE	MOVEMENT CAPACITY mm
AR 202 - 100	Suitable for screed, ceramic, drywall and etc	100	100	15	165	Mill Finish Alu.+TPE	±50
AR 202 - 101	Suitable for screed, ceramic, drywall and etc. (floor gasketed)	100	100	15	165	Mill Finish Alu.+TPE	±16
AR 202 - 102	Suitable for screed, ceramic, drywall and etc. (decorative and narrowed gasket)	100	100	15	165	Anodised Alu.+TPE	±14
AR 203 - 100	Suitable for screed, ceramic, drywall and etc. (14-18 mm)	100	100	20	165	Mill Finish Alu.+TPE	±50
AR 221 - 100	Suitable for facade with its externally proofed feature	100	100	50+5	157	Mill Finish Alu.+TPE	±50
AR 221 - 101	Suitable for heat insulations and facade and etc. (floor gasketed)	100	100	50+5	157	Mill Finish Alu.+TPE	±16
AR 221 - 102	Suitable for heat insulations and facade and etc. (flat gasketed)	100	100	50+5	157	Mill Finish Alu.+TPE	±16
AR 285 - 100	Suitable with internal areas and facade. (seismic)	100	120	55	120	Mill Finish Alu.+TPE	±75

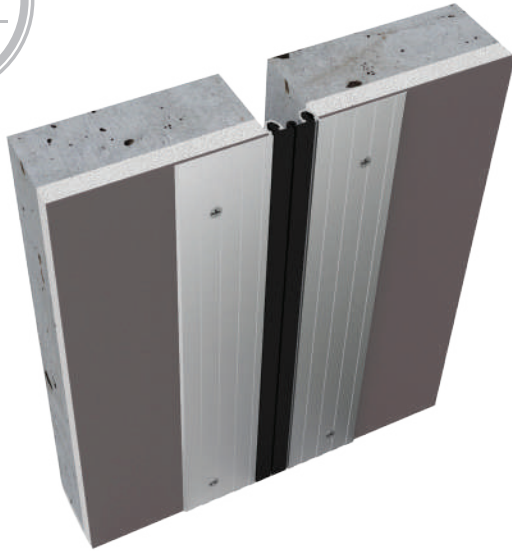

» AR251-030

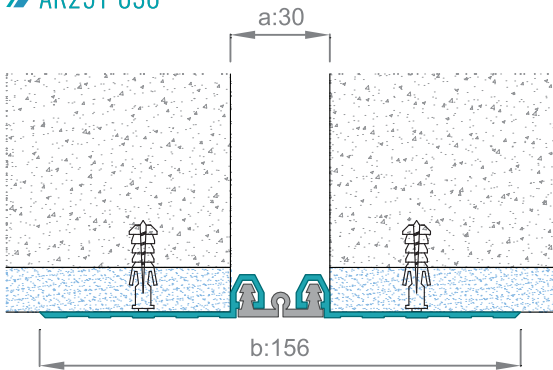

» AR253-030

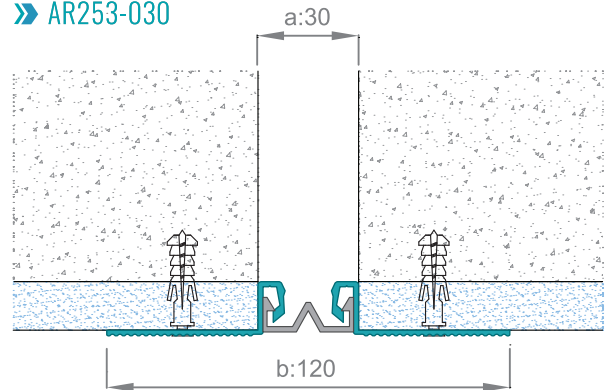

» AR262-030

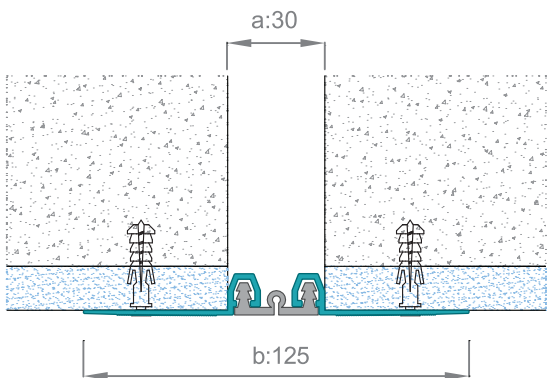

» AR262-030K

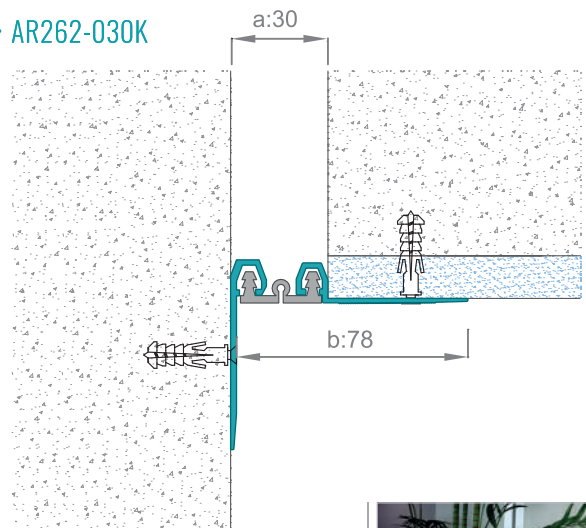

GASKET COLOURS

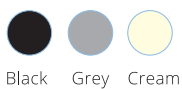

Over Finish Expansion Joint Profiles are suitable for 30 mm gap. Recommended for structures where subjected to thermal factors and small movements. Each design has corner profile option. Profiles are delivered by 3 meters and gaskets 25 meters.

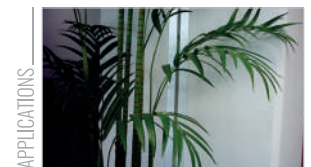

PRODUCT CODE	DESCRIPTION	JOINT WIDTH (a) mm	VISIBLE SURFACE (b) mm	PROFILE HEIGHT (h) mm	TOTAL WIDTH (s) mm	SURFACE	MOVEMENT CAPACITY mm
AR 251- 030	Anodised wide top surface	30	156	12	156	Anodised Alu.+TPE	±10
AR 253 - 030	Mill Finish Wall- Ceiling profile	30	120	14	120	Mill Finish Alu.+TPE	±10
AR 255 - 030	Mill Finish wide top surface	30	180	14	180	Mill Finish Alu.+TPE	±10
AR 260 - 030	Anodised, Screw holed, decorative	30	125	12	125	Anodised Alu.+TPE	±10
AR 262 - 030	Anodised, screw holed, decorative, economic	30	125	12	125	Anodised Alu.+TPE	±10



» AR252-050

» AR254-050

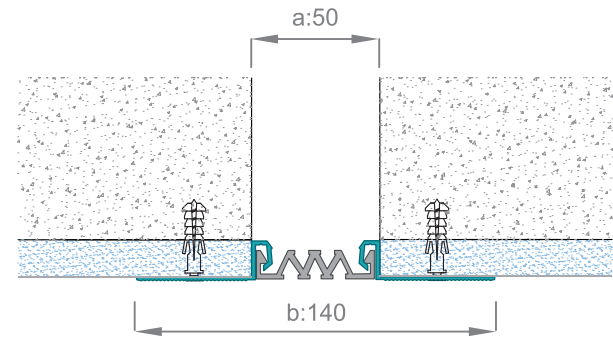
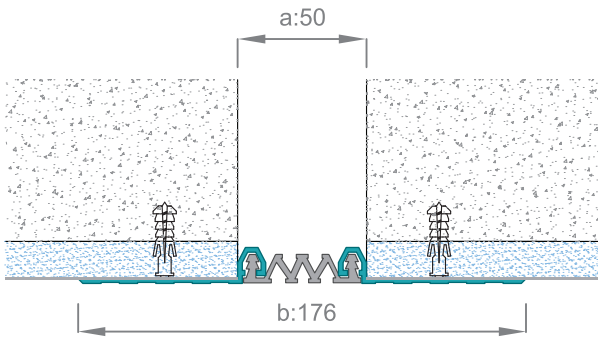

» AR262-050

» AR262-051

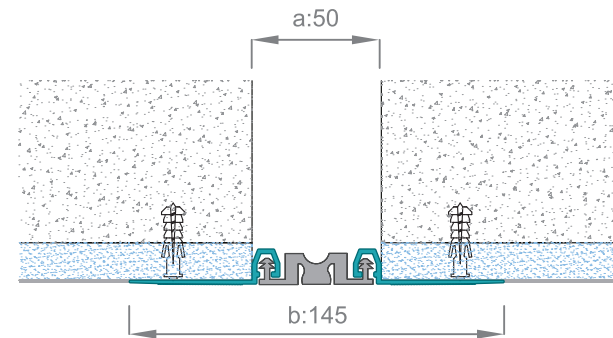
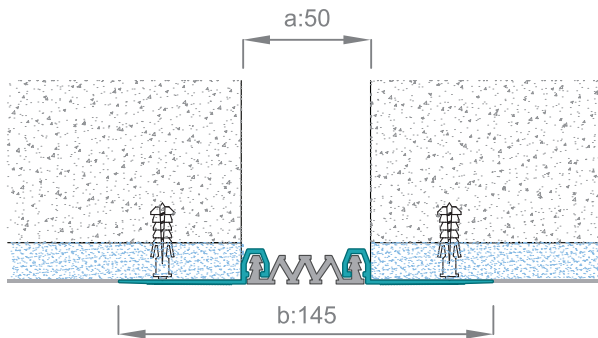

GASKET COLOURS

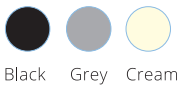

Surface mounted Expansion Joint Profiles are suitable for 50 mm gap. Mat Anodized and polished profile options are available. Screw holes are made as part of the production. Can be easily assembled and compatible to floor profiles. (Shown in page 12)



PRODUCT CODE	DESCRIPTION	JOINT WIDTH (a) mm	VISIBLE SURFACE (b) mm	PROFILE HEIGHT (h) mm	TOTAL WIDTH (s) mm	SURFACE	MOVEMENT CAPACITY mm
AR 252 - 050	Anodised wide top surface	50	176	12	176	Anodised Alu.+TPE	±20
AR 252 - 051	Anodised wide top surface (Floor gasketed)	50	176	12	176	Anodised Alu.+TPE	±10
AR 254 - 050	Mill Finish Wall- Ceiling profile	50	140	14	140	Mill Finish Alu.+TPE	±20
AR 255 - 050	Mill Finish wide top surface	50	200	14	200	Mill Finish Alu.+TPE	±20
AR 261 - 050	Anodised, Screw holed, decorative	50	145	12	145	Anodised Alu.+TPE	±20
AR 262 - 050	Anodised, screw holed, decorative, economic	50	145	12	145	Anodised Alu.+TPE	±20
AR 262 - 051	Anodised, screwed hole/ floor gasketed	50	145	12	145	Anodised Alu.+TPE	±10

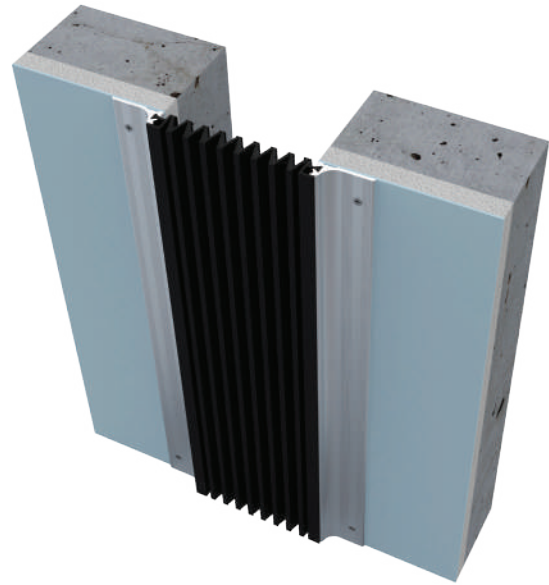

» AR262-080

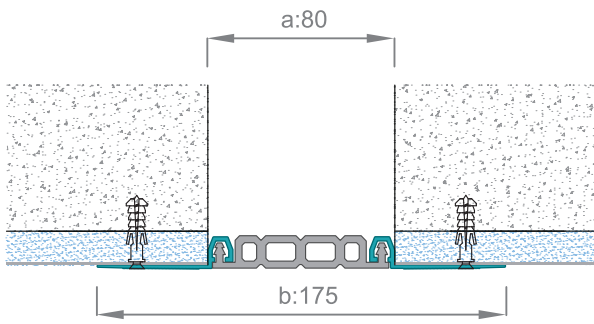

» AR262-100

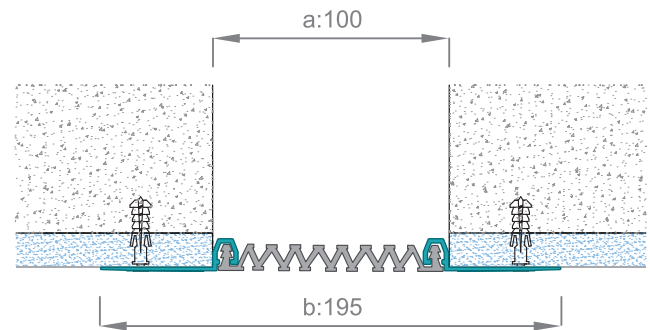

» AR252-100

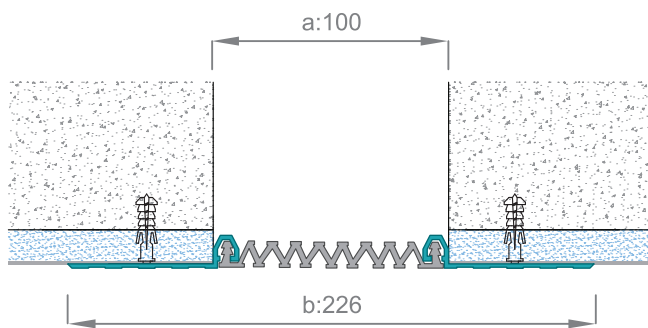

» AR295-100

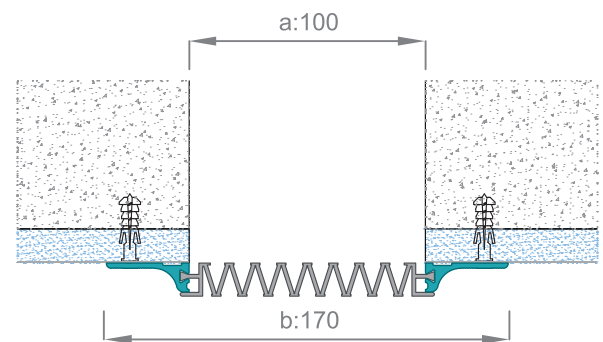

GASKET COLOURS

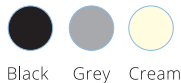

Surface mounted wall-ceiling Expansion Joint Profiles are suitable for 80-100 mm gap with alternative gasket options. Used for ceilings and its high movement capacity can be an alternative to seismic profiles

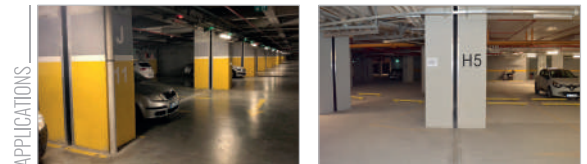

PRODUCT CODE	DESCRIPTION	JOINT WIDTH (a) mm	VISIBLE SURFACE (b) mm	PROFILE HEIGHT (h) mm	TOTAL WIDTH (s) mm	SURFACE	MOVEMENT CAPACITY mm
AR 262 - 080	Anodised, screw holed, decorative, economic	80	175	12	175	Anodised Alu.+TPE	±10
AR 252 - 100	Anodised wide top surface	100	226	12	226	Anodised Alu.+TPE	±50
AR 254 - 100	Mill Finish Wall- Ceiling profile	100	188	14	188	Mill Finish Alu.+TPE	±50
AR 255 - 100	Mill Finish wide top surface	100	250	14	250	Mill Finish Alu.+TPE	±50
AR 261 - 100	Anodised, Screw holed, decorative	100	195	12	195	Anodised Alu.+TPE	±50
AR 262 - 100	Anodised, screw holed, decorative, economic	100	195	12	195	Anodised Alu.+TPE	±50
AR 262 - 101	Anodised, screwed hole/ floor gasketed	100	195	12	195	Anodised Alu.+TPE	±16
AR 262 - 102	Anodised, Screw holed, decorative narrow gasketed	100	190	12	190	Anodised Alu.+TPE	±14
AR 295 - 100	Mill Finish, screw holed, accordion gasketed.	100	170	14	170	Mill Finish Alu.+TPE	+100/-60

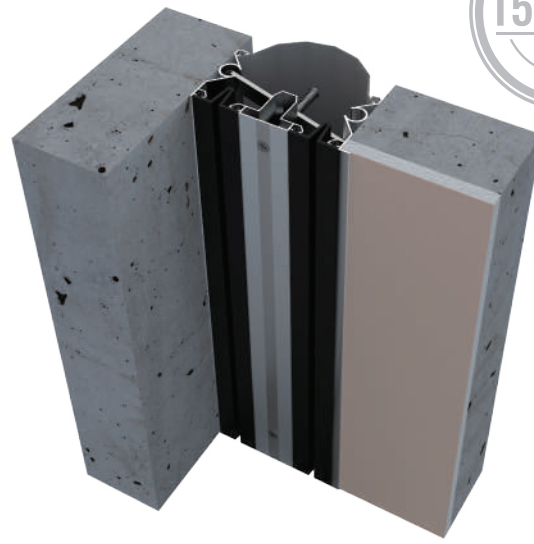

» AR285-150

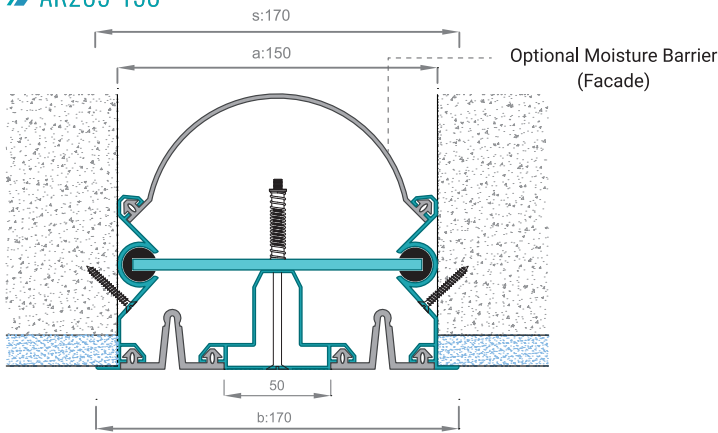

» AR285-150 K

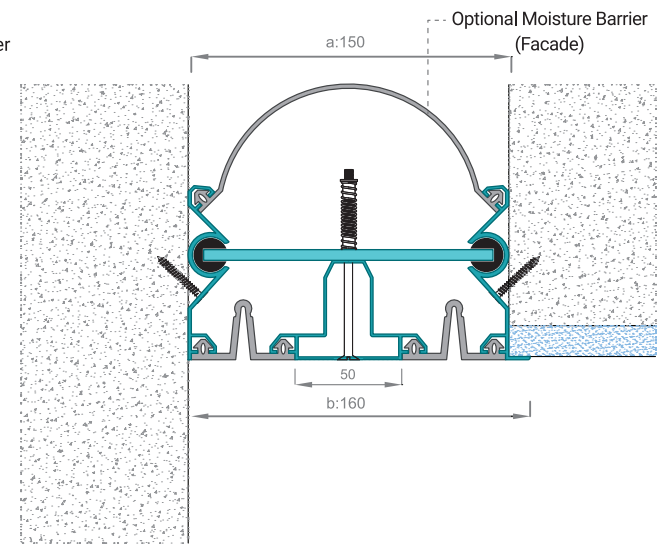

» AR285-200

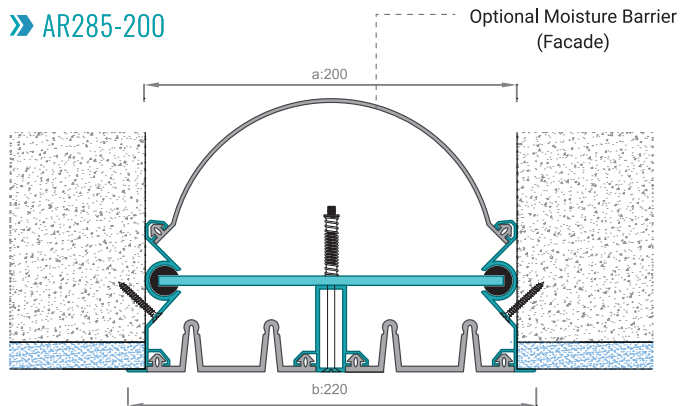

» AR295-150

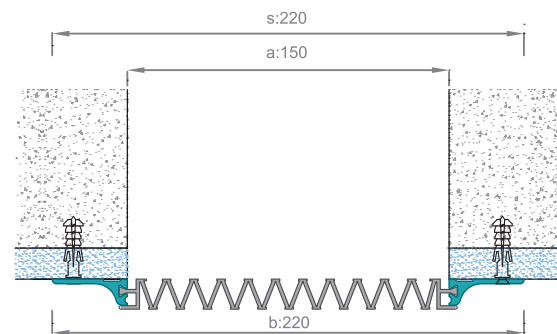

GASKET COLOURS

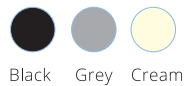

Under and Over finish Expansion Joint Profiles are suitable for larger gaps (150-200-250 mm). Decorative and suitable for high movements. Can also be used at Facade of the structures.



PRODUCT CODE	DESCRIPTION	JOINT WIDTH (a) mm	VISIBLE SURFACE (b) mm	PROFILE HEIGHT (h) mm	TOTAL WIDTH (s) mm	SURFACE	MOVEMENT CAPACITY mm
AR 285 - 150	Suitable for internal or external areas (seismic)	150	170	80	170	Mill Finish Alu.+TPE	±75
AR 295 - 150	Mill Finish, screw holed, accordion gasketed.	150	220	14	220	Mill Finish Alu.+TPE	+150/-90
AR 285 - 200	Suitable for internal or external areas (seismic)	200	220	80	220	Mill Finish Alu.+TPE	±100
AR 295 - 200	Mill Finish, screw holed, accordion gasketed	200	270	14	270	Mill Finish Alu.+TPE	+200/-130

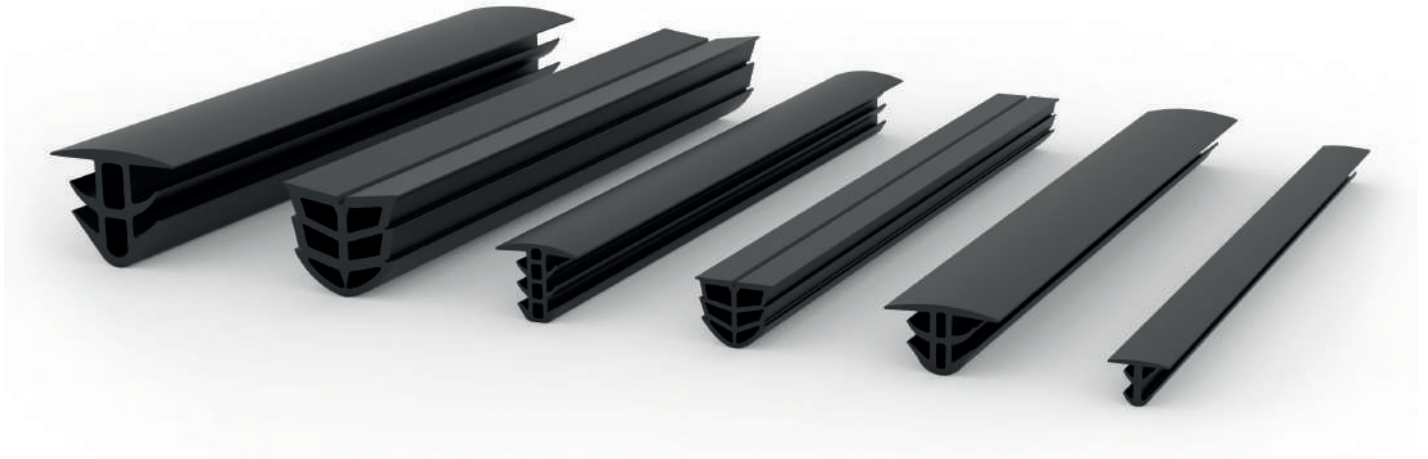

» AR500-01

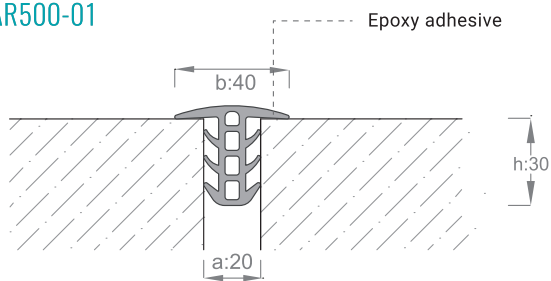

» AR500-01
CORNER APPLICATION

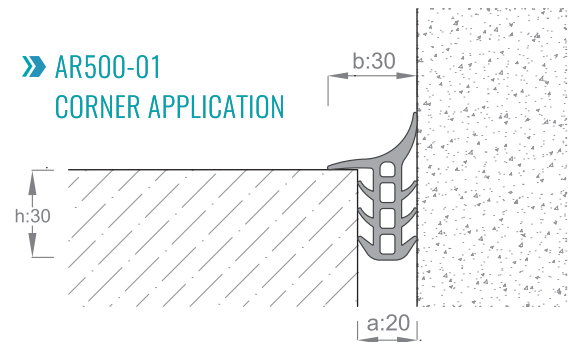

» AR500-01A

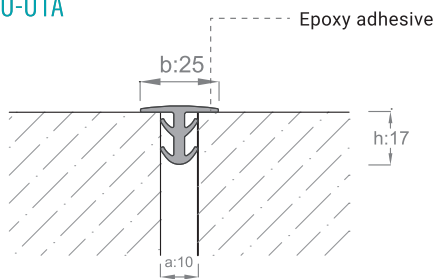

» AR500-02

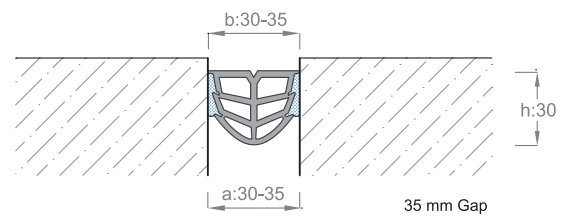

» AR500-01B

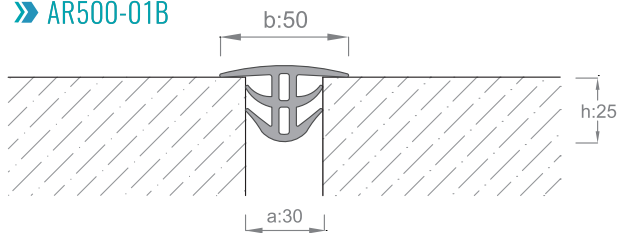

» AR500-02A

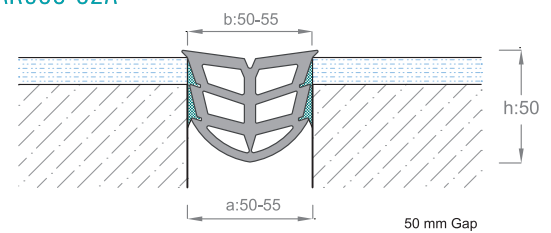

» AR500-01C

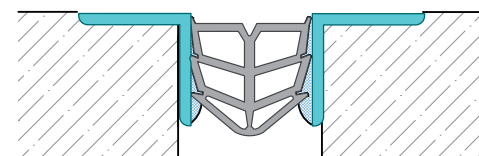
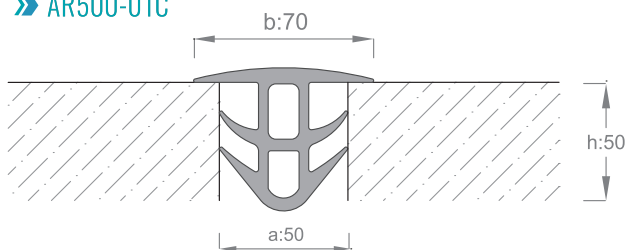

50 mm gap for stainless steel corner

TPE, TPV (optional) profiles made from scratch and suitable for precast elements, facade, drywall applications and compacted laminate applications. Easy and Practical on assembly.





» AR500-05

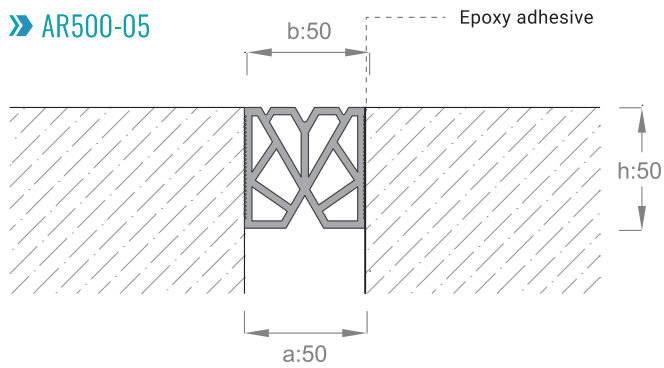

» AR500-06

» AR500-05

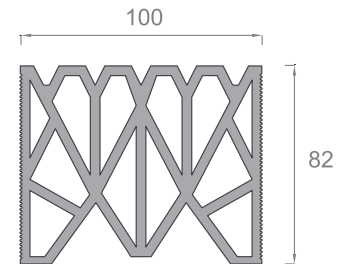
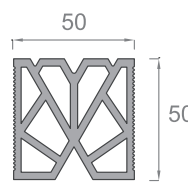

» AR500-07

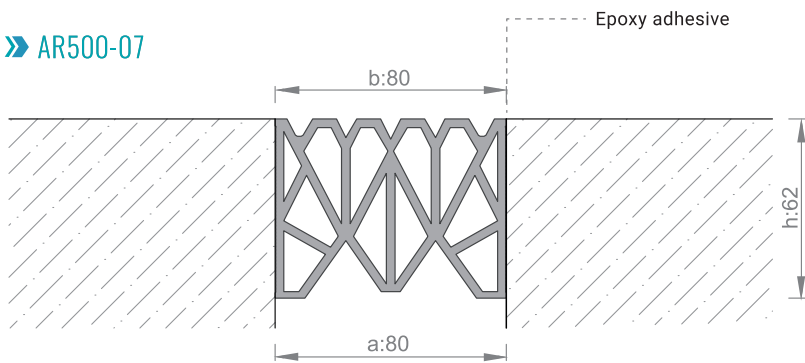

» AR500-03

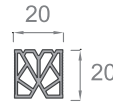

» AR500-04

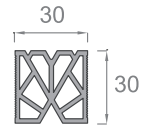

» AR500-51

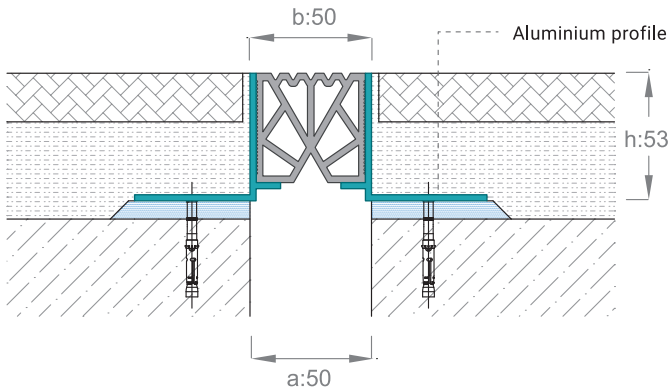

» AR193-050

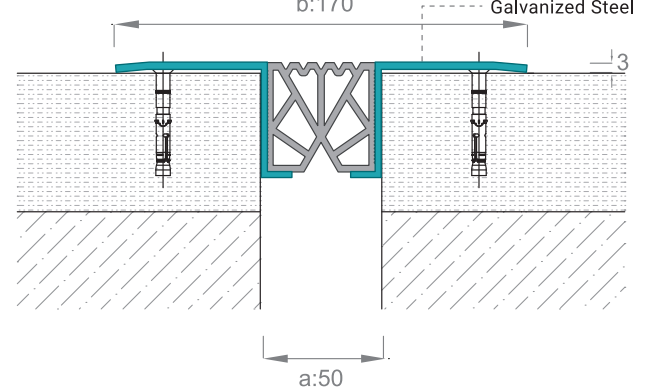

Products made from Thermoplastic elastomer material are suitable for 30, 50, 100 mm gaps and used in floors, walls and ceilings.

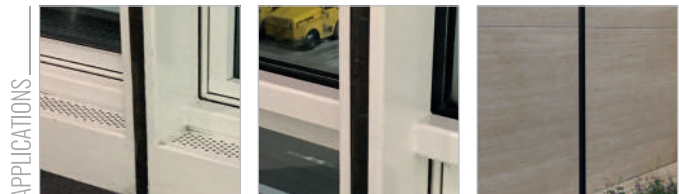

APPLICATIONS

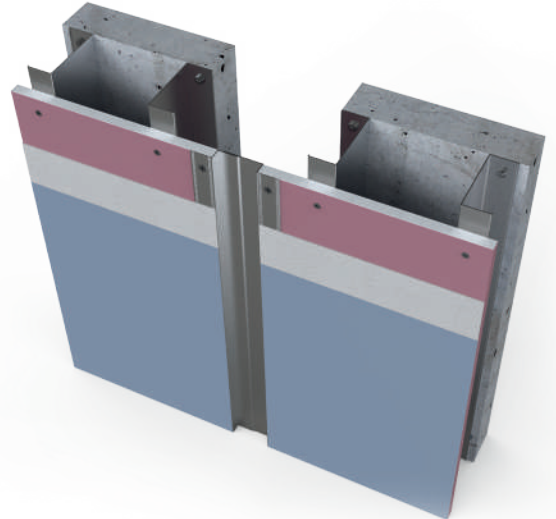
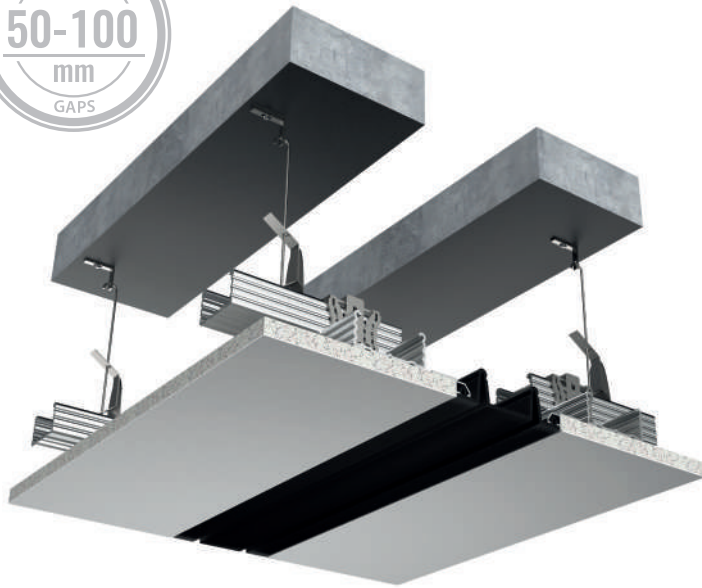

» AR287-050

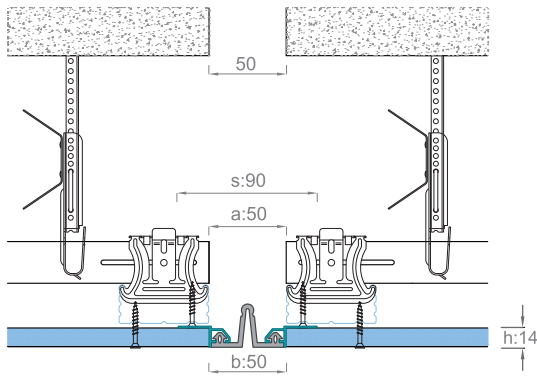

» AR287-100

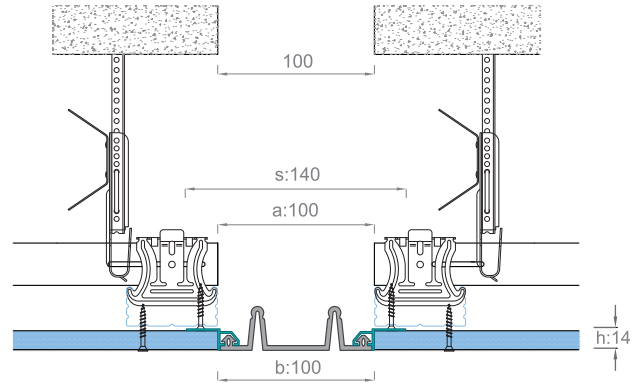

» ARF50

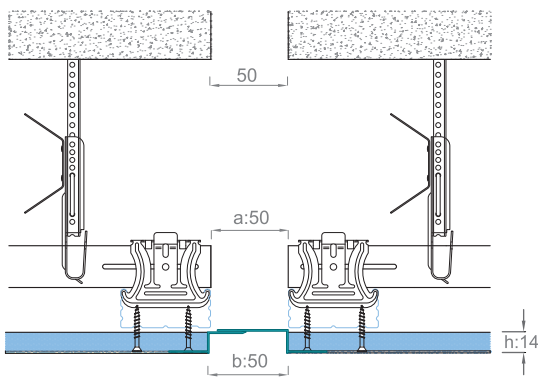

» AR60DT

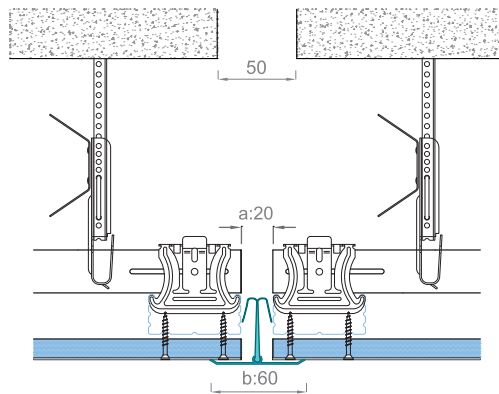

GASKET COLOURS

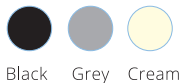

Suspended Ceiling Expansion joint profiles used for various types of Suspended Ceilings. They are decorative and come with gasket or fully aluminium profiles.

APPLICATIONS



PRODUCT CODE	JOINT WIDTH (a) mm	VISIBLE SURFACE (b) mm	PROFILE HEIGHT (h) mm	TOTAL WIDTH (s) mm	SURFACE	MOVEMENT CAPACITY mm
AR 287 - 050	50	50	14	90	Mill Finish Alu.+TPE	±25
AR 287 - 100	100	100	14	140	Mill Finish Alu.+TPE	±75
ARF50	50	50	14	100	Anodised Alu.	±15
AR60DT	20	60	-	60	Anodised Alu.	+15

Floor, Wall, Ceiling, cover profiles

FLOOR, WALL,
CEILING,
COVER PROFILES

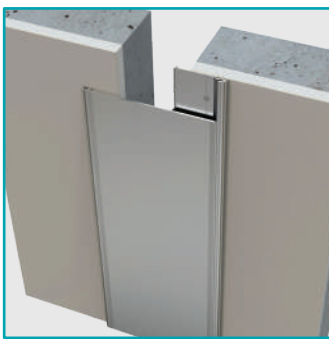
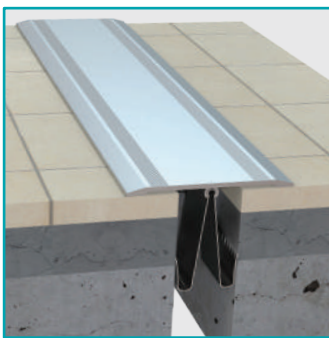
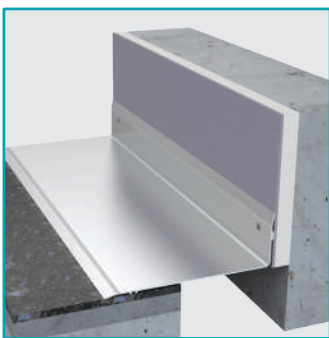

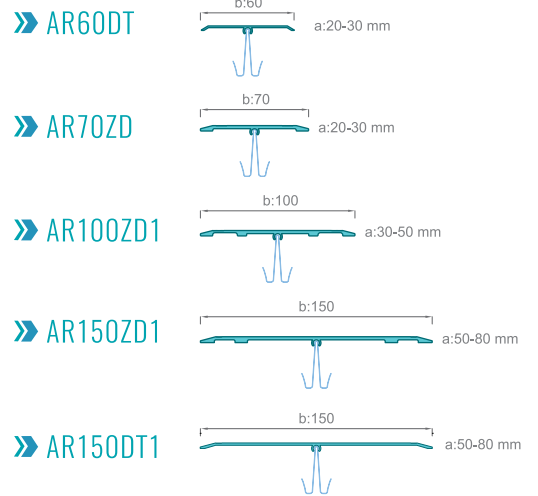
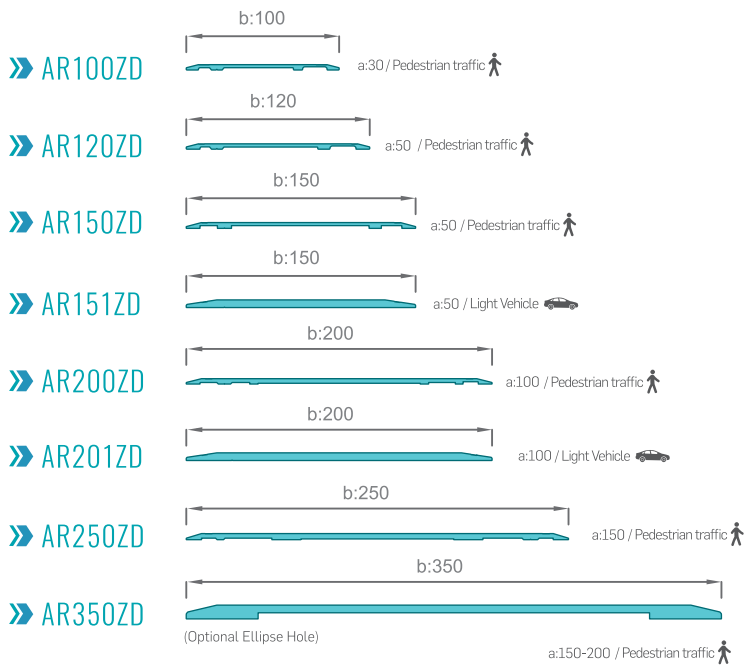
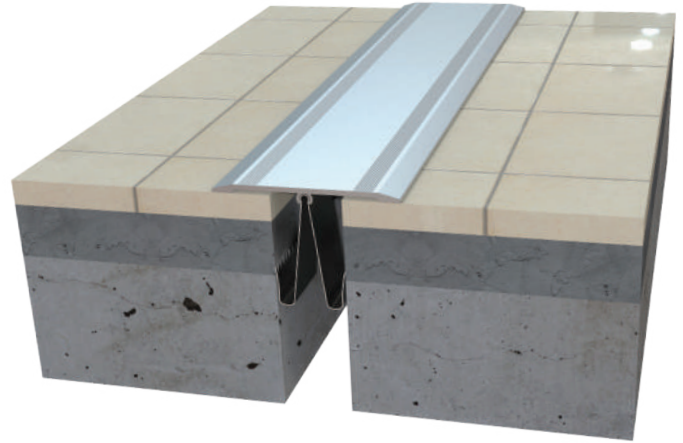

Can be applied with clips system (without needing screws) to standard dimensioned gaps.

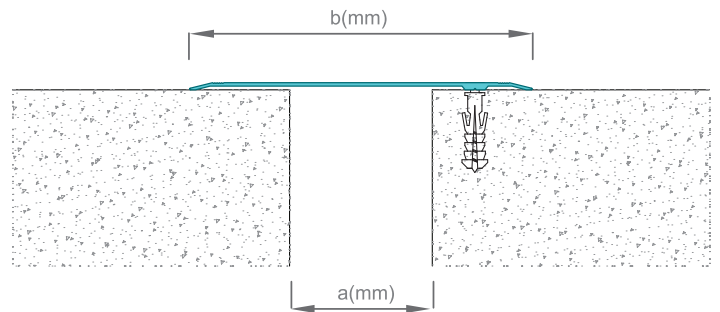
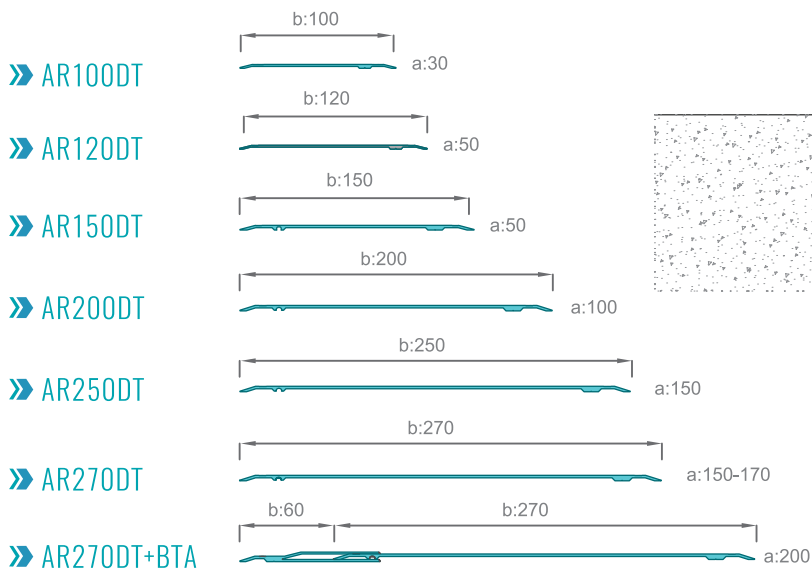

Practical on assembly with one side screw hole. Anodized cover profiles can easily be applied to floors, walls and ceilings.

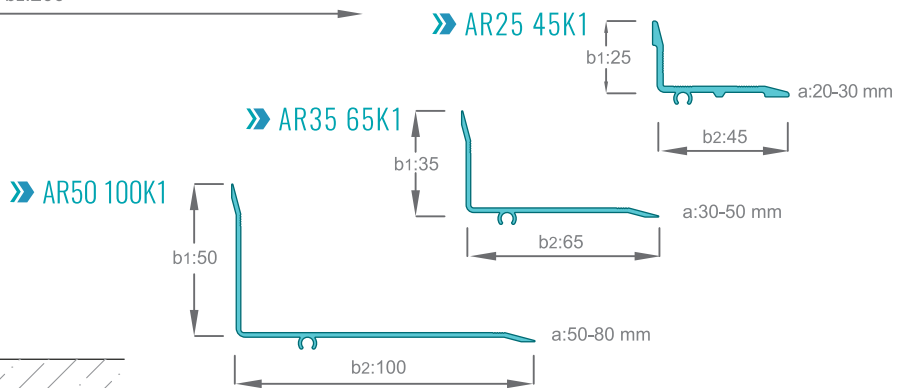
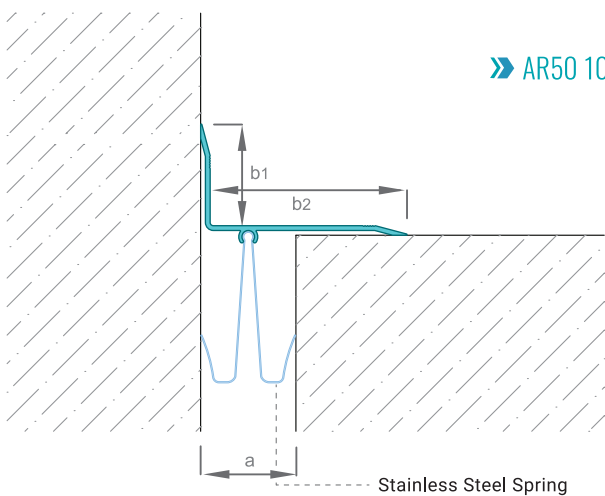
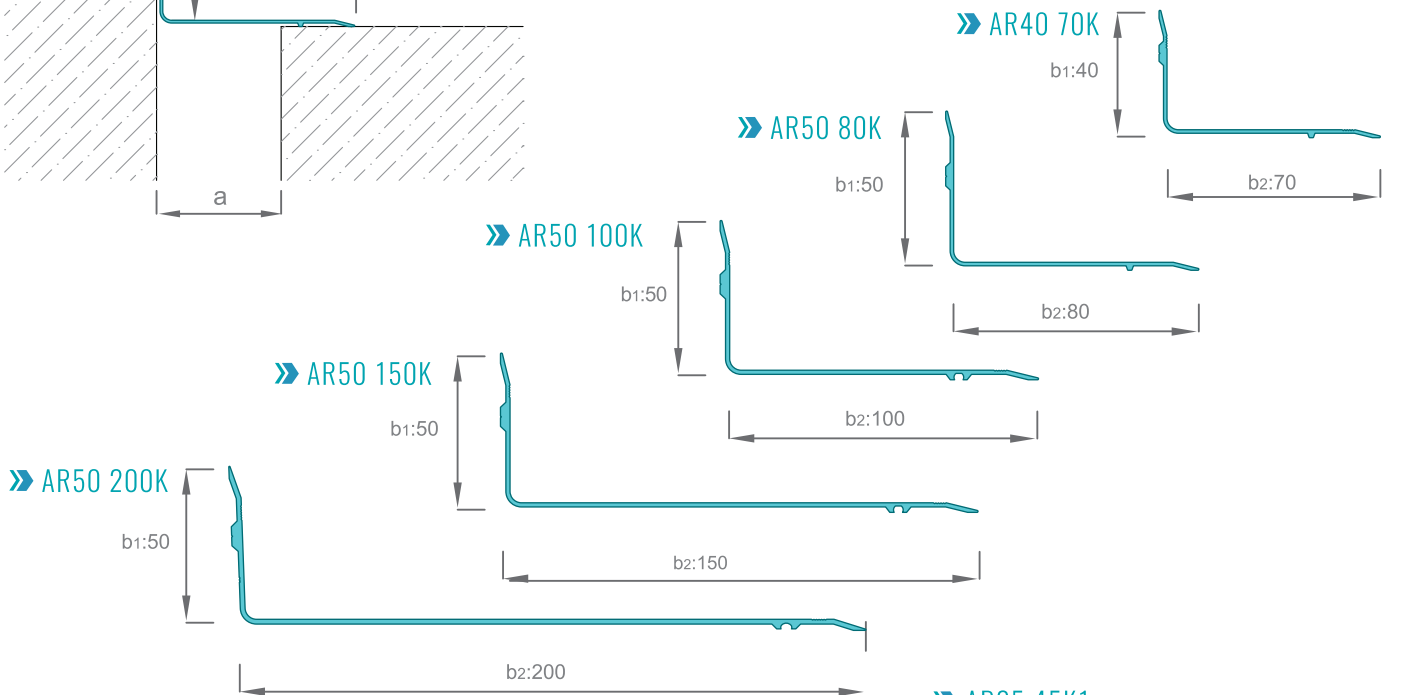
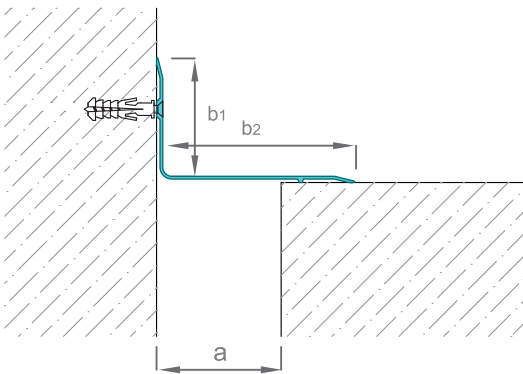
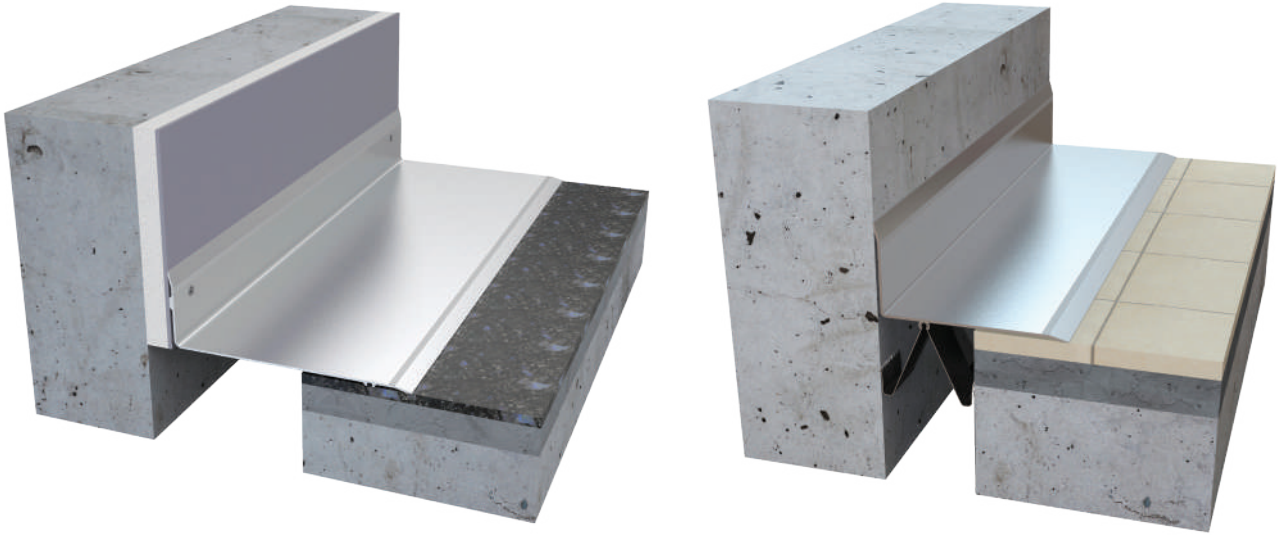

Corner Cover Profiles are compatible with straight cover profiles and used in Floors, Walls and Ceilings.



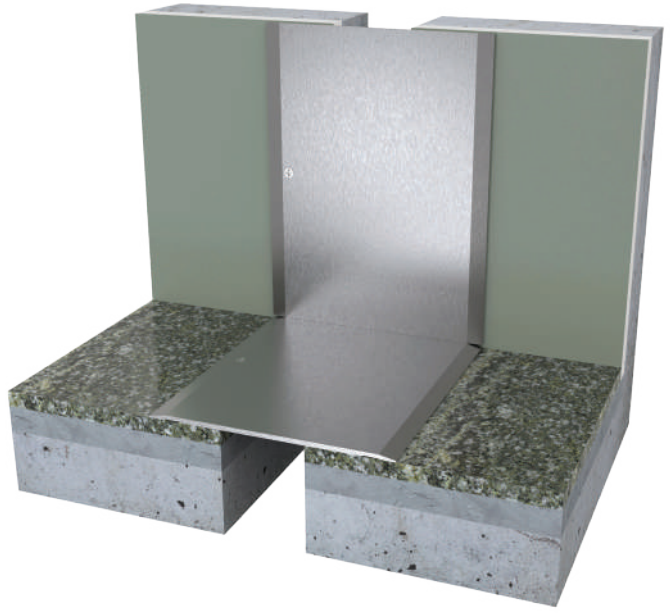

» AR151DT

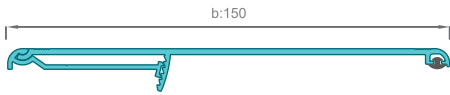

» AR201DT

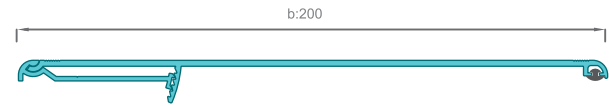

» AR50 101K

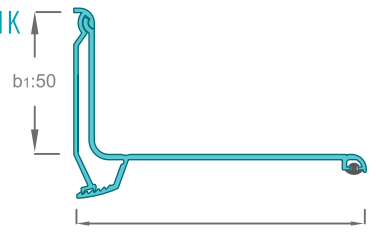

» AR50 151K

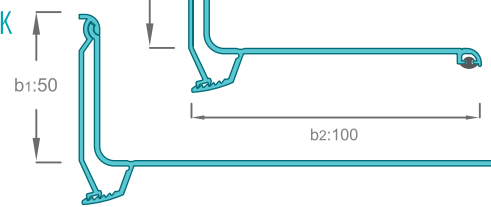

» AR50 201K

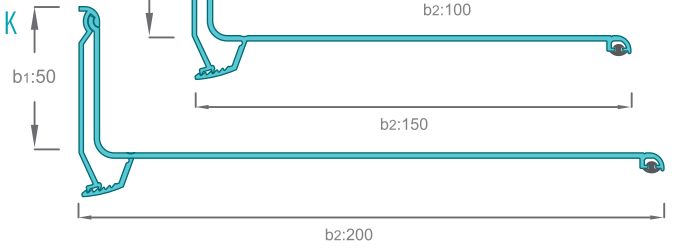

STAINLESS STEEL COVER PROFILES

» AR100ZS



» AR100DS

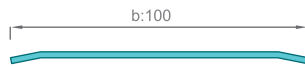

» AR120ZS

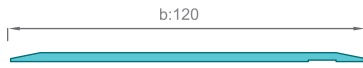

» AR120DS



» AR150ZS

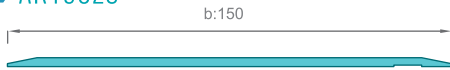

» AR150DS



» AR200ZS

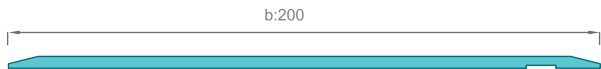

» AR200DS

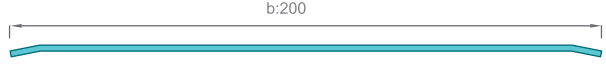

» AR40 80ZKS

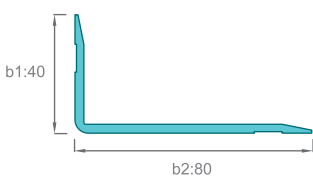

» AR40 80DKS

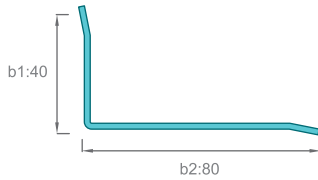

APPLICATIONS



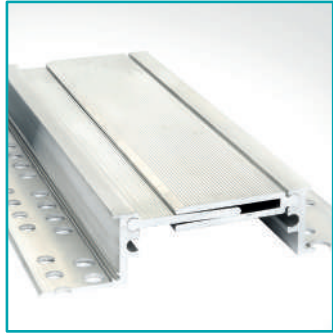
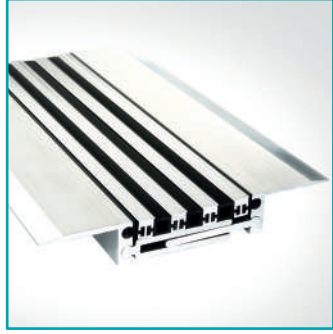
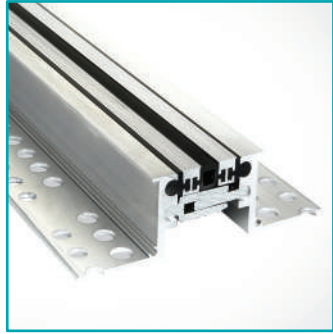
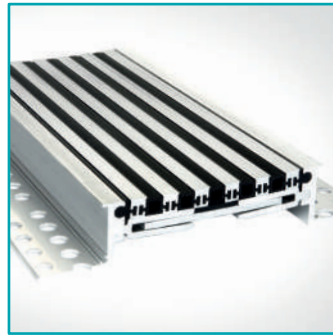
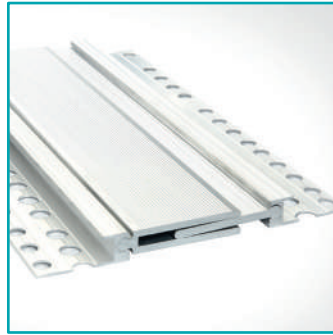

300 Series Floor, Wall and Ceiling Profiles

300 SERIES
FLOOR, WALL,
CEILING, PROFILES



» AR300-035

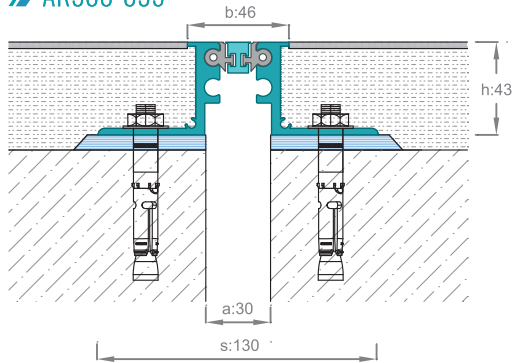

» AR301-050

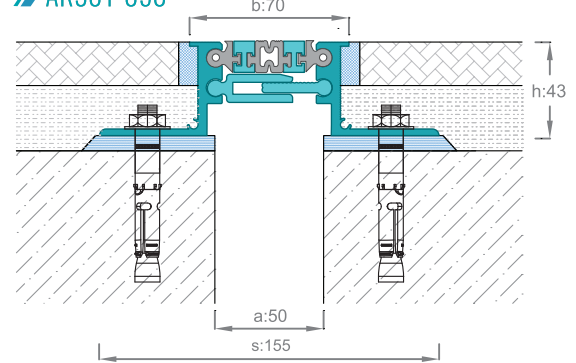

» AR301-051B

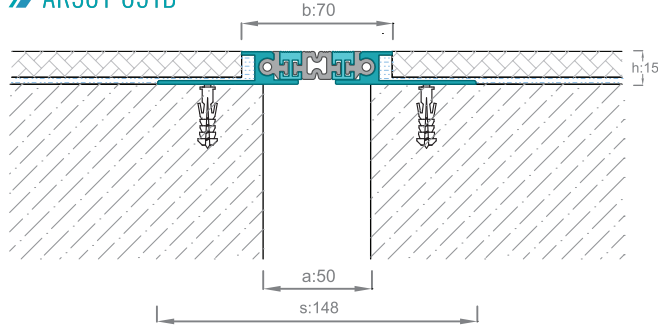

» AR301-050K

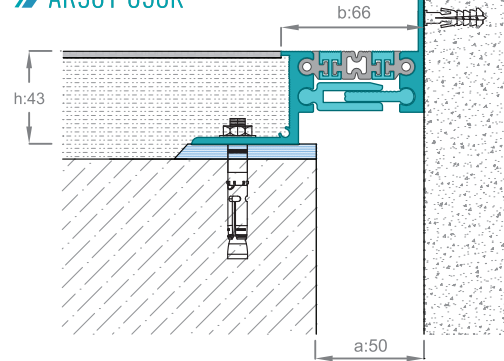

» AR301-051B



» AR301-051



» AR301-052



» AR301-050



» AR301-053



» AR301-054

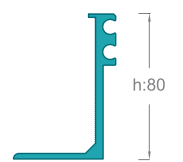

The 300 series dilatation profiles consisting of aluminium lamellae and TPE gaskets. The 300 series can be used in areas such as shopping malls, light industrial buildings, warehouses, hospitals, airports and subways which are exposed to medium vehicle and intense pedestrian load. It is suitable for many flooring types such as; ceramic, granite, marble, screed and industrial floors with various foot heights. Pre-mounted and prepared in 3 meters lengths for delivery. It is fixed to the floor with anchors with 35 cm spacing on both sides.



PRODUCT CODE	DESCRIPTION	JOINT WIDTH (a) mm	VISIBLE SURFACE (b) mm	PROFILE HEIGHT (h) mm	TOTAL WIDTH (s) mm	SURFACE	MOVEMENT CAPACITY mm	LOAD CAPACITY
AR300-035	Foot height is required to be specified.	30	46	14/28/43/60/80	130	Mill Finish Alu.+TPE	±5	30 Ton 6.5 Ton
AR301-050	Suitable with screed, granite, marble and etc.	50	70	43	155	Mill Finish Alu.+TPE	±10	15 Ton 3.5 Ton
AR301-051	Suitable with ceramic.	50	70	14	165	Mill Finish Alu.+TPE	±10	Pedestrian Load 1.5 Ton
AR301-051B	Suitable with ceramic and economic	50	70	15	148	Mill Finish Alu.+TPE	±10	Pedestrian Load
AR301-052	Suitable with natural granite, marble and etc.	50	70	28	155	Mill Finish Alu.+TPE	±10	2.5 Ton
AR301-053	Suitable with screed, granite, marble and etc.	50	70	60	155	Mill Finish Alu.+TPE	±10	15 Ton 3.5 Ton
AR301-054	Suitable with screed, granite, marble and etc.	50	70	80	155	Mill Finish Alu.+TPE	±10	15 Ton 3.5 Ton

Note: Footings heights of 14, 15, and 28 mm are only suitable for light vehicles



300 SERIES
FLOOR, WALL,
CEILING, PROFILES

» AR303-100

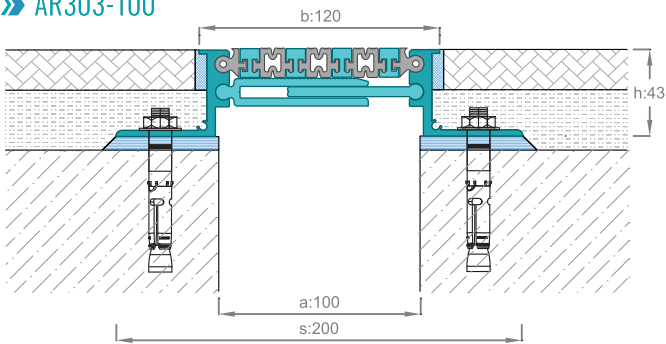

» AR303-100K

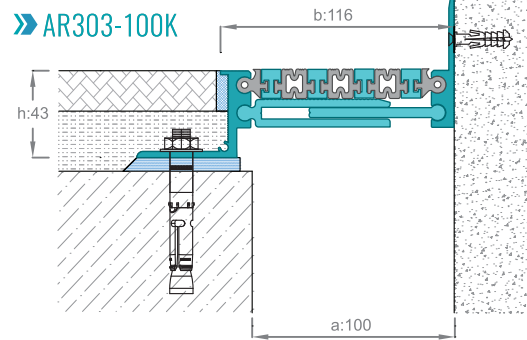

» AR303-101

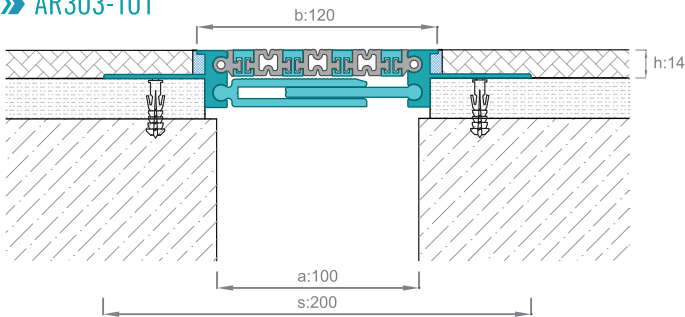

» AR304-100

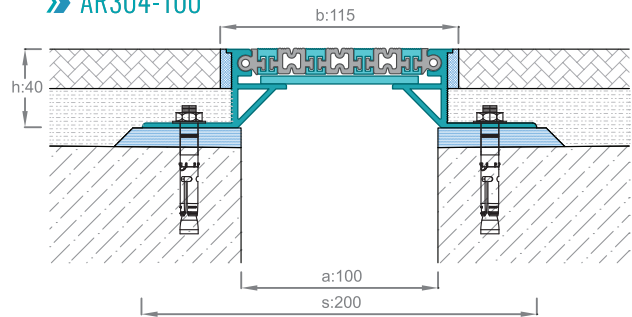

» AR303-101



» AR303-102



» AR303-100



» AR303-103



» AR303-104

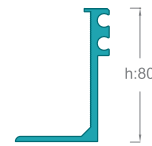

303 and 304 series can be used in all kinds of buildings such as shopping centres, hospitals, government buildings and business centres. These can also be used in areas exposed to vehicle traffic with minimum footing height of 43 mm

PRODUCT CODE	DESCRIPTION	JOINT WIDTH (a) mm	VISIBLE SURFACE (b) mm	PROFILE HEIGHT (h) mm	TOTAL WIDTH (s) mm	SURFACE	MOVEMENT CAPACITY mm	LOAD CAPACITY
AR302-081	Suitable with ceramic.	80	100	14	190	Mill Finish Alu.+TPE	± 12	Pedestrian Load
AR302-082	Suitable with natural granite, marble and etc.	80	100	28	185	Mill Finish Alu.+TPE	±12	Pedestrian Load 1.5 Ton
AR302-080	Suitable with screed, granite, marble and etc.	80	100	43/60/80	185	Mill Finish Alu.+TPE	±12	3.5 Ton 2.5 Ton
AR303-101	Suitable with ceramic.	100	120	14	210	Mill Finish Alu.+TPE	±15	Pedestrian Load
AR303-102	Suitable with natural granite, marble and etc.	100	120	28	200	Mill Finish Alu.+TPE	±15	Pedestrian Load
AR303-100	Suitable with screed, granite, marble and etc.	100	120	43/60/80	200	Mill Finish Alu.+TPE	±15	3 Ton 1.5 Ton
AR304-100	Suitable with granite and economic.	100	115	40	200	Mill Finish Alu.+TPE	±15	Pedestrian Load

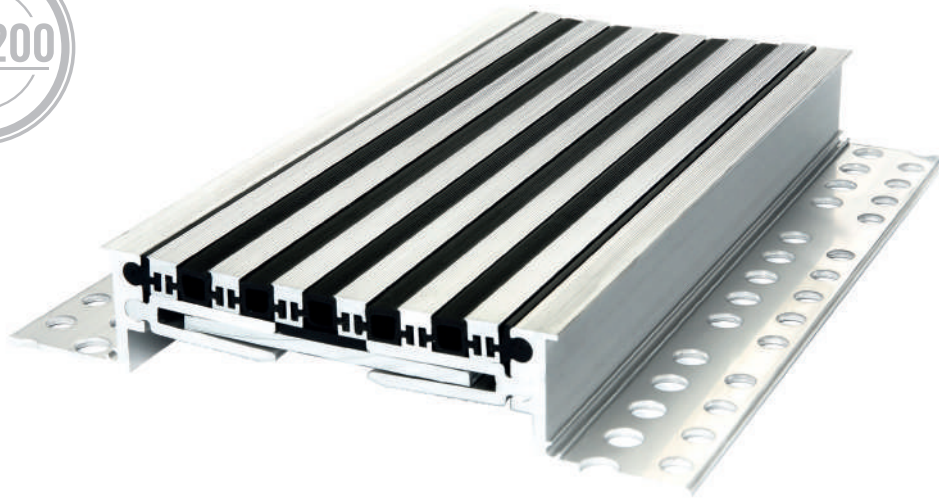

» AR303-150

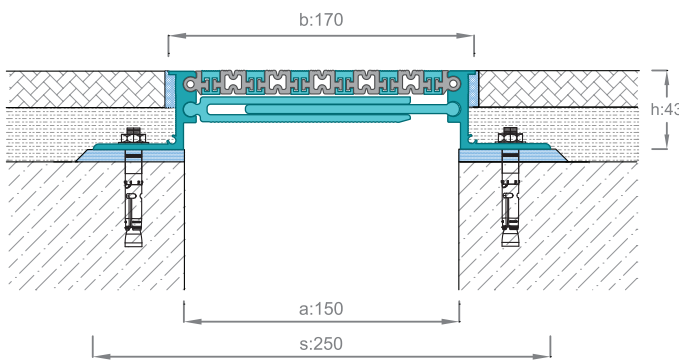

» AR303-150K

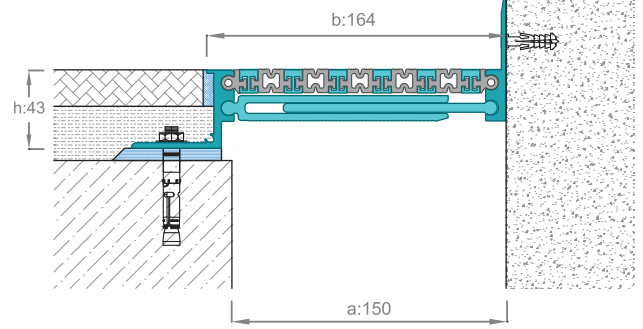

» AR303-200

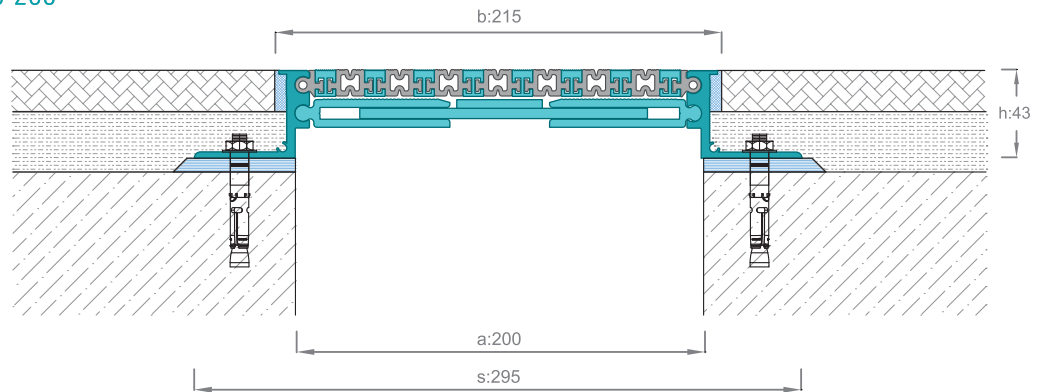

» AR303-150



» AR303-153



» AR303-154

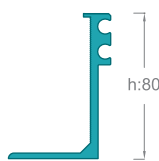

The 300 series floor Expansion joint Profiles used for 150 mm and 200 mm gaps and generally utilized in areas exposed to pedestrian load. It is assembled with steel anchors and screws with 35 cm spacing from both sides. Mounted and prepared in 3 meters lengths for delivery.

APPLICATIONS



PRODUCT CODE	DESCRIPTION	JOINT WIDTH (a) mm	VISIBLE SURFACE (b) mm	PROFILE HEIGHT (h) mm	TOTAL WIDTH (s) mm	SURFACE	MOVEMENT CAPACITY mm	LOAD CAPACITY
AR 303 - 150	Suitable with granite, marble and etc.	150	168	43, 60, 80	250	Mill Finish Alu.+TPE	±25	Pedestrian Load
AR 303 - 200	Suitable with granite, marble and etc.	200	215	43, 60, 80	295	Mill Finish Alu.+TPE	±35	Pedestrian Load



300 SERIES
FLOOR, WALL,
CEILING, PROFILES

» AR308-050

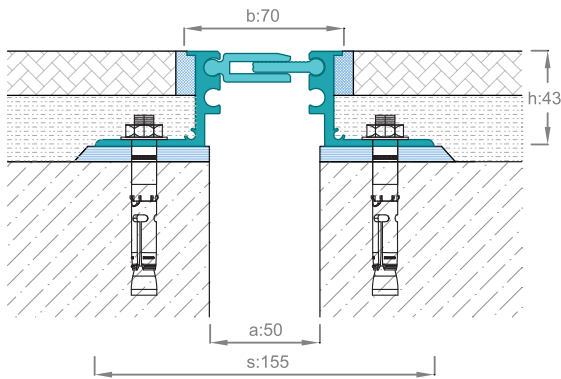

» AR309-100

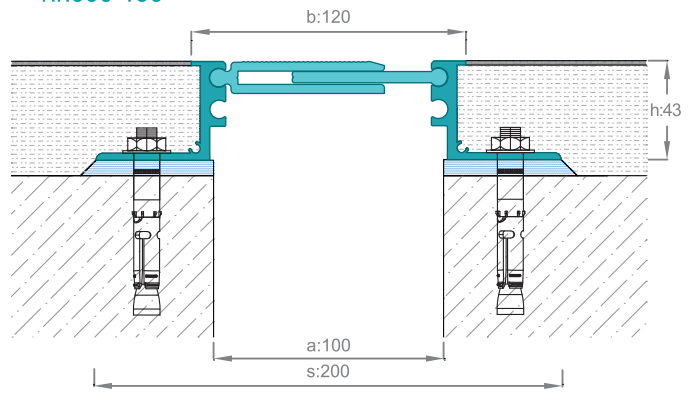

» AR309-150

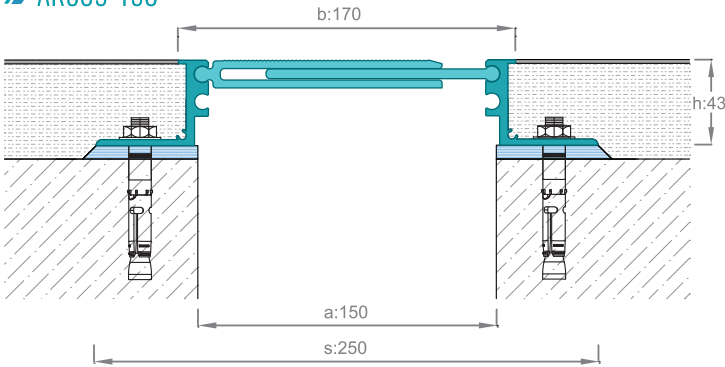

» AR309-150K

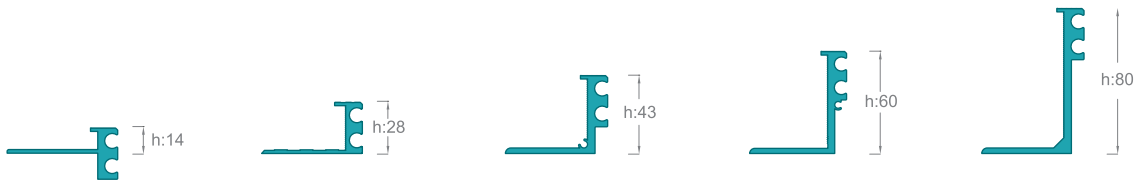
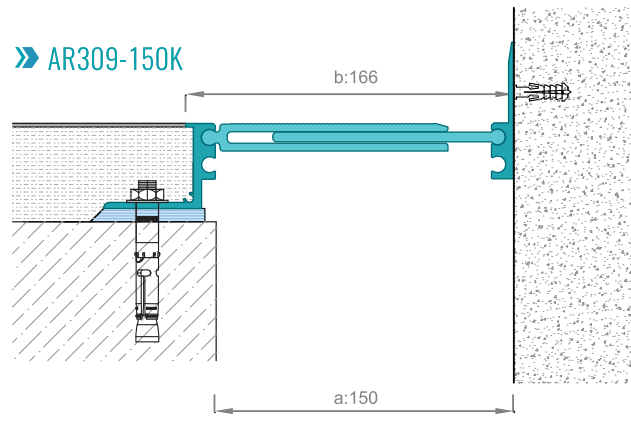

Horizontally and vertically movable, decorative and economical under finish Expansion Joint Profiles are fully covered in Aluminium surface.



PRODUCT CODE	DESCRIPTION	JOINT WIDTH (a) mm	VISIBLE SURFACE (b) mm	PROFILE HEIGHT (h) mm	TOTAL WIDTH (s) mm	SURFACE	MOVEMENT CAPACITY mm	LOAD CAPACITY
AR308-051	Suitable with ceramic.	50	70	14	165	Mill Finish Alu.	± 10	Pedestrian Load
AR308-052	Suitable with natural granite, marble and etc.	50	70	28	155	Mill Finish Alu.	±10	Pedestrian Load 1.5 Ton
AR308-050	Suitable with screed, granite, marble and etc.	50	70	43/60/80	155	Mill Finish Alu.	±10	3.5 Ton 2.5 Ton
AR309-080	Footing height is required to be specified	80	100	14/28/43/60/80	185	Mill Finish Alu.	±12	3.5 Ton
AR309-100	Footing height is required to be specified	100	120	14/28/43/60/80	200	Mill Finish Alu.	±15	1.5 Ton
AR309-150	Footing height is required to be specified	150	170	43/60/80	250	Mill Finish Alu.	±25	Pedestrian Load



» AR172-050

» AR174-100

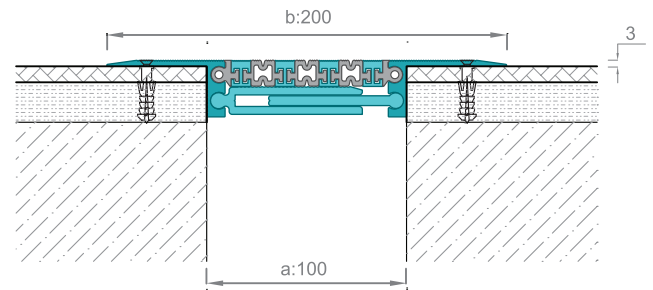
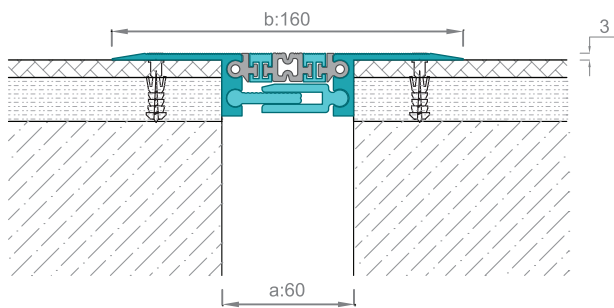

» AR174-150

» AR184-100

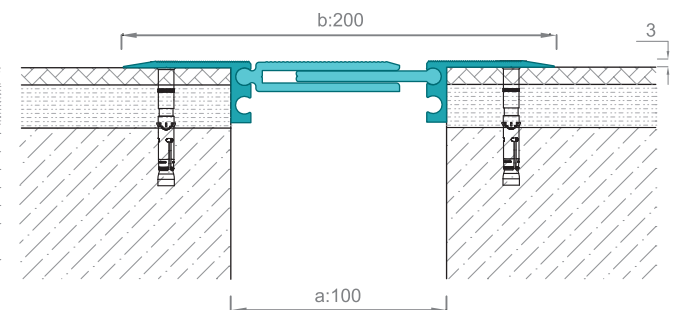
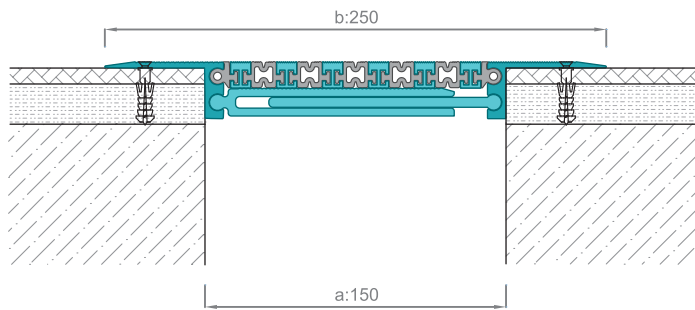

Expansion Joint Profiles suitable for joint gaps from 35mm to 200 mm. These decorative profiles come with screw holes on both sides. TPE gasket options available are at grey and black colour.



PRODUCT CODE	DESCRIPTION	JOINT WIDTH (a) mm	VISIBLE SURFACE (b) mm	PROFILE HEIGHT (h) mm	TOTAL WIDTH (s) mm	SURFACE	MOVEMENT CAPACITY mm	LOAD CAPACITY
AR 171 - 035	Mill Finish, screw holed, alu&TPE top surface.	35	135	26	135	Mill Finish Alu.+TPE	±5	5 Ton 2.5 Ton
AR 172 - 050	Mill Finish, screw holed, alu&TPE top surface.	60	160	26	160	Mill Finish Alu.+TPE	±10	3.5 Ton 2 Ton
AR 173 - 080	Mill Finish, screw holed, alu&TPE top surface.	80	180	26	180	Mill Finish Alu.+TPE	±12	2.5 Ton
AR 174 - 100	Mill Finish, screw holed, alu&TPE top surface.	100	200	26	200	Mill Finish Alu.+TPE	±15	Pedestrian Load
AR 174 - 150	Mill Finish, screw holed, alu&TPE top surface.	150	250	26	250	Mill Finish Alu.+TPE	±25	Pedestrian Load
AR 174 - 200	Mill Finish, screw holed, alu&TPE top surface.	200	300	26	300	Mill Finish Alu.+TPE	±35	Pedestrian Load
AR 182 - 050	Mill Finish, screw holed, alu. top surface.	60	160	26	160	Mill Finish Alu.	±10	3.5 Ton
AR 183-080	Mill Finish, screw holed, alu. top surface.	80	180	26	180	Mill Finish Alu.	±12	2.5 Ton
AR 184 - 100	Mill Finish, screw holed, alu. top surface.	100	200	26	200	Mill Finish Alu.	±15	Pedestrian Load
AR 184 - 150	Mill Finish, screw holed, alu. top surface	150	250	26	250	Mill Finish Alu.	±25	Pedestrian Load



300 SERIES
FLOOR, WALL,
CEILING, PROFILES

» AR208-030

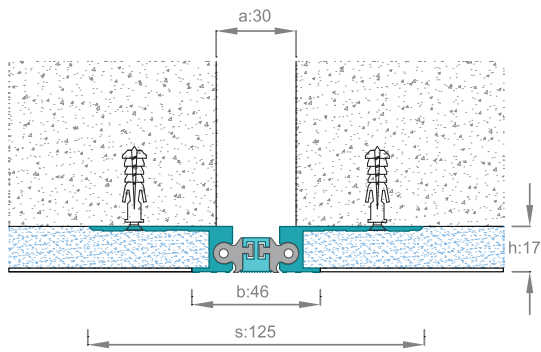

» AR209-050

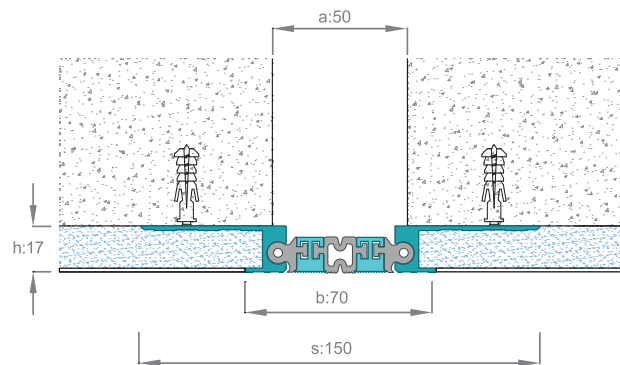

» AR211-100

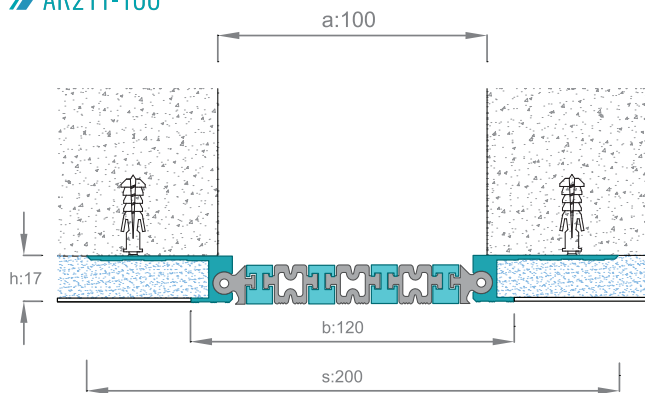

» AR212-100

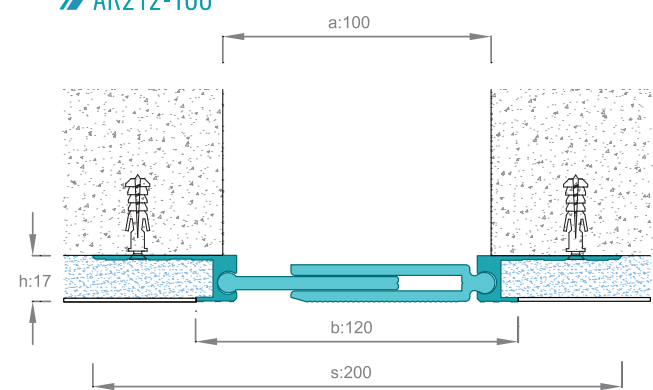

Adaptable to walls and ceilings which are compatible with AR 300 series floor profiles. Can be used in coverings such as, plaster, ceramic and drywall.

PRODUCT CODE	DESCRIPTION	JOINT WIDTH (a) mm	VISIBLE SURFACE (b) mm	PROFILE HEIGHT (h) mm	TOTAL WIDTH (s) mm	SURFACE	MOVEMENT CAPACITY mm
AR 208 - 030	Suitable with screed, ceramic, drywall and etc. / Aluminium & Gasketed top surface	30	46	17	125	Mill Finish Alu.+TPE	±5
AR 209 - 050	Suitable with screed, ceramic, drywall and etc. / Aluminium & Gasketed top surface	50	70	17	150	Mill Finish Alu.+TPE	±10
AR 210 - 080	Suitable with screed, ceramic, drywall and etc. / Aluminium & Gasketed top surface	80	100	17	180	Mill Finish Alu.+TPE	±12
AR 211 - 100	Suitable with screed, ceramic, drywall and etc. / Aluminium & Gasketed top surface	100	120	17	200	Mill Finish Alu.+TPE	±14
AR 211 - 150	Suitable with screed, ceramic, drywall and etc. / Aluminium & Gasketed top surface	150	170	17	250	Mill Finish Alu.+TPE	±25
AR 212 - 050	Suitable with screed, ceramic, drywall and etc. / Aluminium top surface	50	70	17	150	Mill Finish Alu.	±10
AR 212 - 080	Suitable with screed, ceramic, drywall and etc. / Aluminium top surface	80	100	17	180	Mill Finish Alu.	±12
AR 212 - 100	Suitable with screed, ceramic, drywall and etc. / Aluminium top surface	100	120	17	200	Mill Finish Alu.	±14
AR 212 - 150	Suitable with screed, ceramic, drywall and etc. / Aluminium top surface	150	170	17	250	Mill Finish Alu.	±25

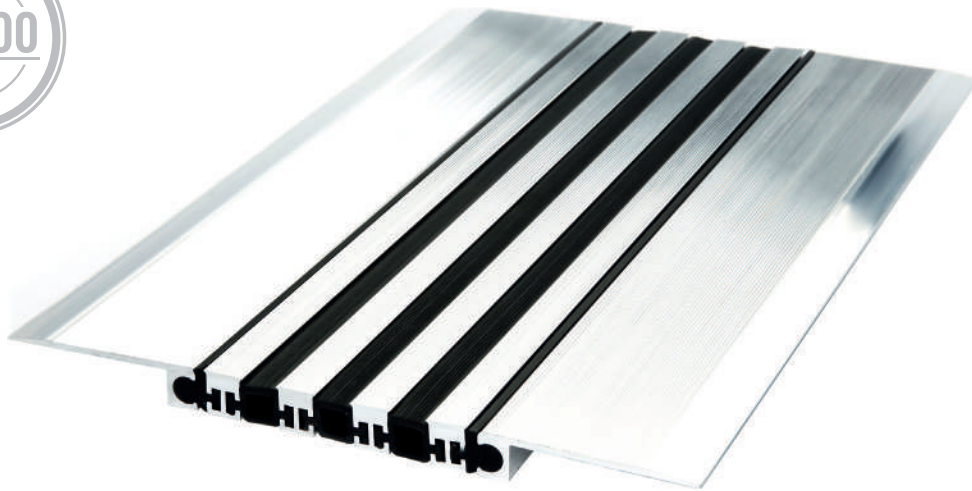

» AR258-030

» AR259-050

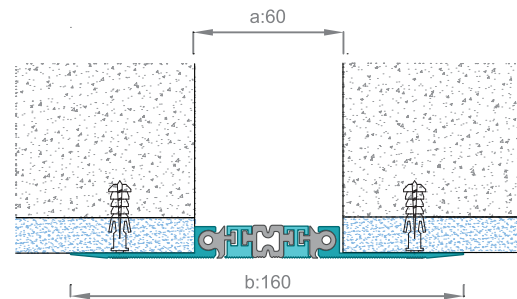
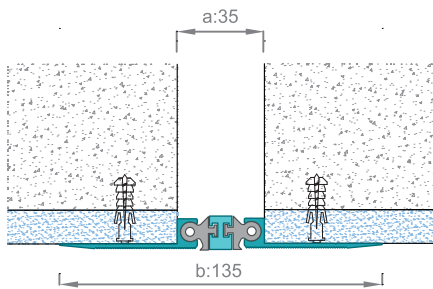

» AR259-100

» AR259-150

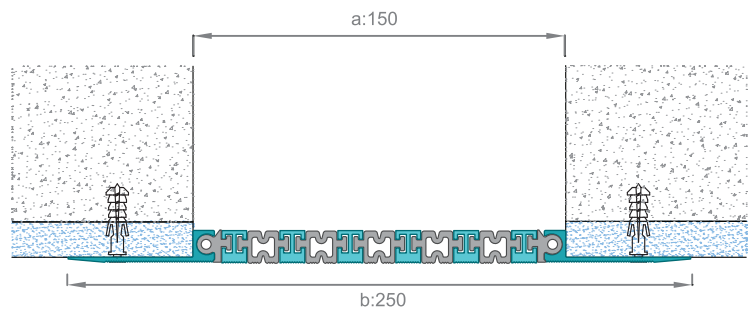
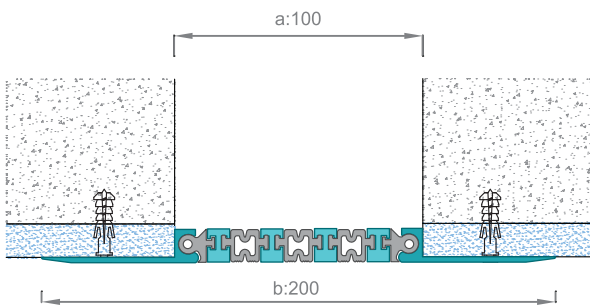

Suitable for Walls and ceilings which are compatible with AR 300 and AR 172 series floor profiles. Surface mounted Expansion Joint Profiles fitted from screw holes on both sides before delivery.

APPLICATIONS



PRODUCT CODE	DESCRIPTION	JOINT WIDTH (a) mm	VISIBLE SURFACE (b) mm	PROFILE HEIGHT (h) mm	TOTAL WIDTH (s) mm	SURFACE	MOVEMENT CAPACITY mm
AR 258 - 030	Mill Finish, screw holed, alu&TPE top surface	35	135	11	135	Mill Finish Alu.+TPE	±5
AR 259 - 050	Mill Finish, screw holed, alu&TPE top surface	60	160	11	160	Mill Finish Alu.+TPE	±10
AR 259 - 080	Mill Finish, screw holed, alu&TPE top surface	80	180	11	180	Mill Finish Alu.+TPE	±12
AR 259 - 100	Mill Finish, screw holed, alu&TPE top surface	100	200	11	200	Mill Finish Alu.+TPE	±14
AR 259 - 150	Mill Finish, screw holed, alu&TPE top surface	150	250	11	250	Mill Finish Alu.+TPE	±25
AR 259 - 200	Mill Finish, screw holed, alu&TPE top surface	200	300	11	300	Mill Finish Alu.+TPE	±35

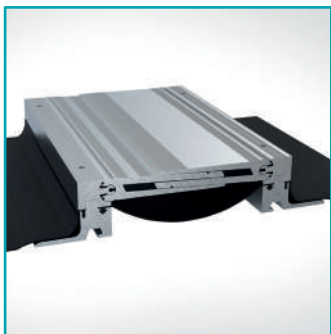
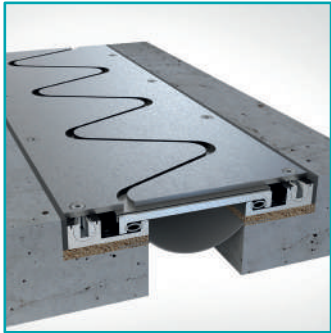

heavy duty and hygienic floor profiles

HEAVY DUTY
AND HYGIENIC
FLOOR PROFILES



» AR703-050

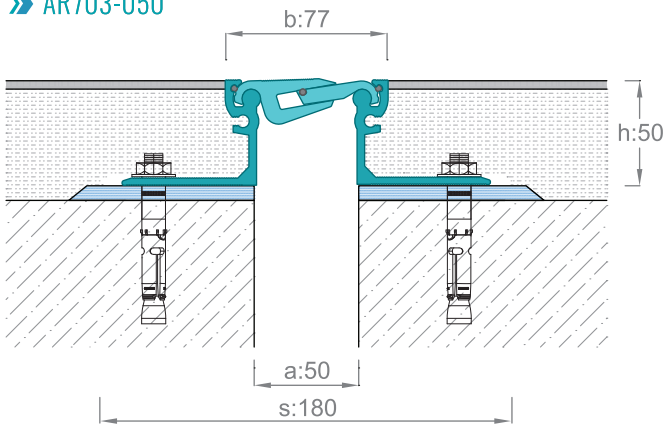

» AR703-050K

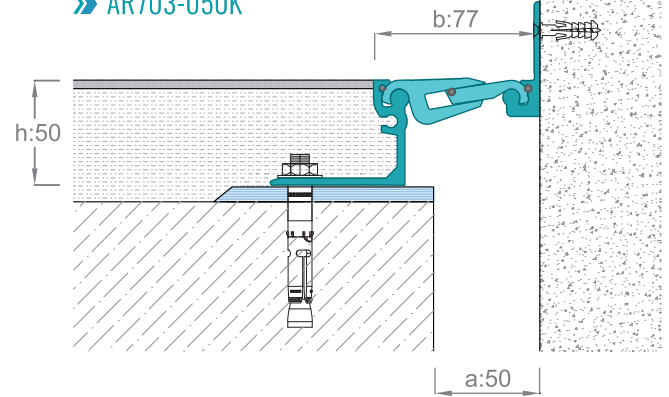

» AR700-050



» AR701-050



» AR702-050



» AR703-050



» AR704-050



» AR705-050

700 series floor to floor profiles are designed to be decorative, hygienic and resistant to heavy loads with special top cross section. Long-term reliable profiles can be used in many different projects such as, shopping malls, heavy industrial structures, hospitals and airports. Production length is 4 meters.

APPLICATIONS



PRODUCT CODE	DESCRIPTION	JOINT WIDTH (a) mm	VISIBLE SURFACE (b) mm	PROFILE HEIGHT (h) mm	TOTAL WIDTH (s) mm	SURFACE	MOVEMENT CAPACITY mm	LOAD CAPACITY
AR700-050	Suitable for Shopping Malls, Hospitals/ Flat top surfaced.	50	77	17	180	Mill Finish Alu.	± 10	3.5 Ton
AR701-050	Suitable for Shopping Malls, Hospitals/ Flat top surfaced.	50	77	30	180	Mill Finish Alu.	± 10	30 Ton 6.5 Ton
AR702-050	Suitable for Shopping Malls, Hospitals/ Flat top surfaced.	50	77	40	180	Mill Finish Alu.	± 10	30 Ton 6.5 Ton
AR703-050	Suitable for Shopping Malls, Hospitals/ Flat top surfaced.	50	77	50	180	Mill Finish Alu.	± 10	30 Ton 6.5 Ton
AR704-050	Suitable for Shopping Malls, Hospitals/ Flat top surfaced.	50	77	60	195	Mill Finish Alu.	± 10	30 Ton 6.5 Ton
AR 705-050	Suitable for Shopping Malls, Hospitals/ Flat top surfaced.	50	77	70	195	Mill Finish Alu.	± 10	30 Ton 6.5 Ton
AR710-080	Suitable for Shopping Malls, Hospitals/ Flat top surfaced.	80	110	17	210	Mill Finish Alu.	± 16	2.5 Ton
AR711-080	Suitable for Shopping Malls, Hospitals/ Flat top surfaced.	80	110	30	210	Mill Finish Alu.	± 16	30 Ton 6.5 Ton
AR712-080	Suitable for Shopping Malls, Hospitals/ Flat top surfaced.	80	110	40	210	Mill Finish Alu.	± 16	30 Ton 6.5 Ton
AR713-080	Suitable for Shopping Malls, Hospitals/ Flat top surfaced.	80	110	50	210	Mill Finish Alu.	± 16	30 Ton 6.5 Ton



» AR723-100

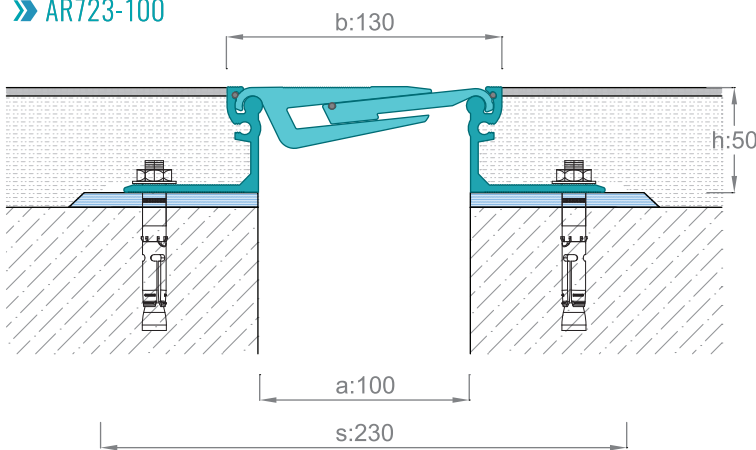

» AR723-100K

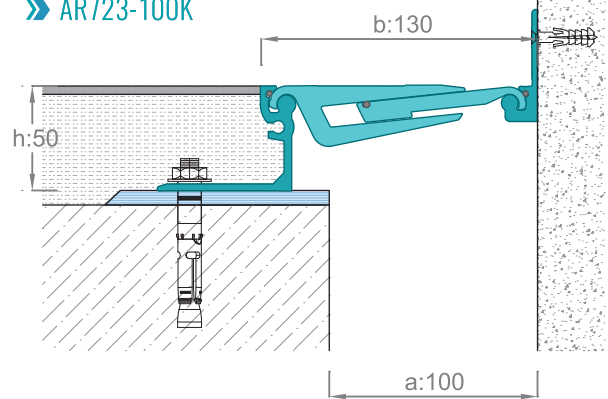

HEAVY DUTY
AND HYGIENIC
FLOOR PROFILES



» AR720-100



» AR721-100



» AR722-100



» AR723-100

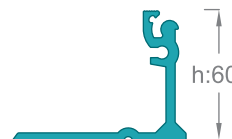

» AR724-100



» AR725-100

Suitable for flooring covers such as, granite, marble, ceramic, industrial screed and PVC floors with different footing heights. Assembled to the floor with steel anchors by having intervals of 35 cm from both sides. Using epoxy mortar is an essential step to avoid any possible breakage which can occur at sides. Each design has its corner option available. Manufactured as in design of T, L + joining detail.

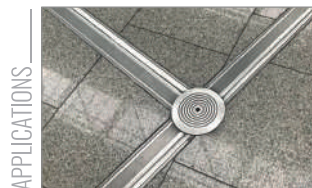

PRODUCT CODE	DESCRIPTION	JOINT WIDTH (a) mm	VISIBLE SURFACE (b) mm	PROFILE HEIGHT (h) mm	TOTAL WIDTH (s) mm	SURFACE	MOVEMENT CAPACITY mm	LOAD CAPACITY
AR714-080	Suitable for Shopping Malls, Hospitals/ Flat top surfaced.	80	110	60	225	Mill Finish Alu.	± 16	30 Ton 6.5 Ton
AR715-080	Suitable for Shopping Malls, Hospitals/ Flat top surfaced.	80	110	70	225	Mill Finish Alu.	± 16	30 Ton 6.5 Ton
AR720-100	Suitable for Shopping Malls, Hospitals/ Flat top surfaced.	100	130	17	230	Mill Finish Alu.	± 20	Pedestrian Load
AR721-100	Suitable for Shopping Malls, Hospitals/ Flat top surfaced.	100	130	30	230	Mill Finish Alu.	± 20	30 Ton 6.5 Ton
AR722-100	Suitable for Shopping Malls, Hospitals/ Flat top surfaced.	100	130	40	230	Mill Finish Alu.	± 20	30 Ton 6.5 Ton
AR723-100	Suitable for Shopping Malls, Hospitals/ Flat top surfaced.	100	130	50	230	Mill Finish Alu.	± 20	30 Ton 6.5 Ton
AR724-100	Suitable for Shopping Malls, Hospitals/ Flat top surfaced.	100	130	60	245	Mill Finish Alu.	± 20	30 Ton 6.5 Ton
AR725-100	Suitable for Shopping Malls, Hospitals/ Flat top surfaced.	100	130	70	245	Mill Finish Alu.	± 20	30 Ton 6.5 Ton



» AR820-050

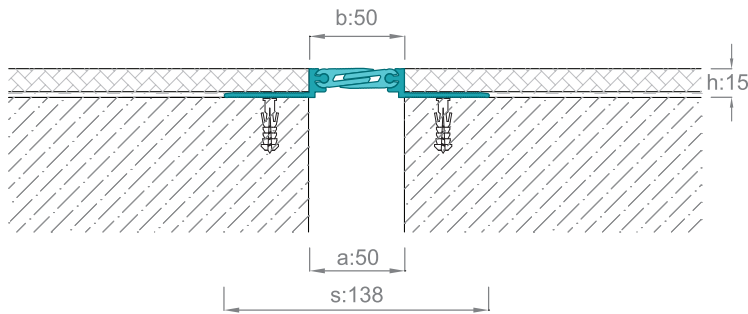

» AR821-030

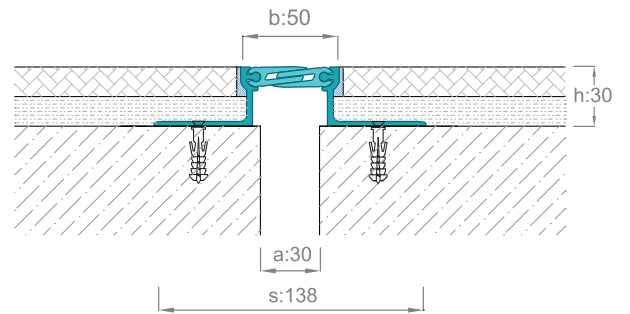

» AR823-100

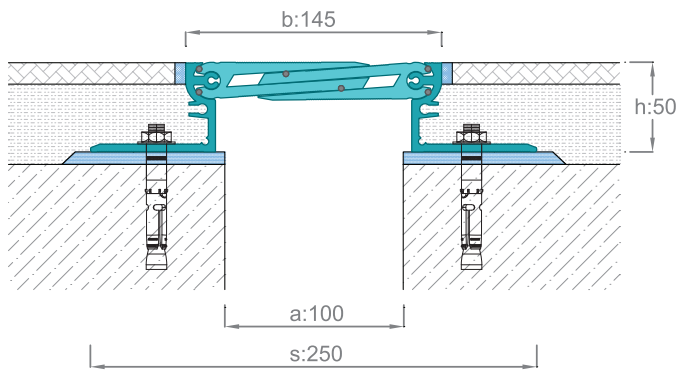

» AR823-101

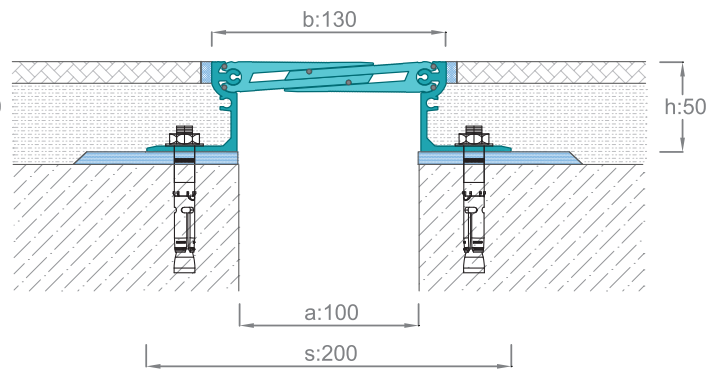

AR 800 series have three dimensional movement capacity and are hygienic, resistant to heavy loads with different footing heights. Suitable for all kinds of flooring types and durable at Shopping centres, hospitals, hotels and industrial structures.

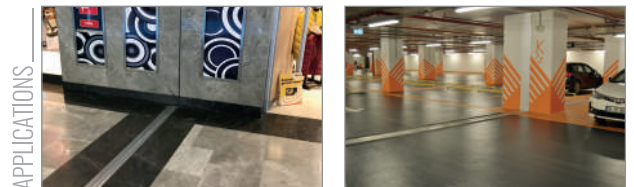

PRODUCT CODE	DESCRIPTION	JOINT WIDTH (a) mm	VISIBLE SURFACE (b) mm	PROFILE HEIGHT (h) mm	TOTAL WIDTH (s) mm	SURFACE	MOVEMENT CAPACITY mm	LOAD CAPACITY
AR 820 - 050	Suitable for Shopping Malls, Hospitals/ Flat top surfaced.	50	50	15	138	Mill Finish Alu.	± 5	Pedestrian Load 2.5 Ton
AR 821 - 030	Suitable for Shopping Malls, Hospitals/ Flat top surfaced.	30	50	30	138	Mill Finish Alu.	± 5	9 Ton 3.5 Ton
AR 823 - 100	Suitable for Shopping Malls, Hospitals/ Flat top surfaced.	100	145	25/40/50/60/70	250	Mill Finish Alu.	± 20	30 Ton 6.5 Ton
AR 823 - 101	Suitable for Shopping Malls, Hospitals/ Flat top surfaced.	100	130	50/60/70/90	200	Mill Finish Alu.	± 18	9 Ton 3.5 Ton
AR 823 - 150	Suitable for Shopping Malls, Hospitals/ Flat top surfaced.	150	210	65	340	Mill Finish Alu.	+30/-25	30 Ton 6.5 Ton
AR 823 - 151	Suitable for Shopping Malls, Hospitals/ Flat top surfaced.	150	160	50	290	Mill Finish Alu.	± 20	9 Ton 3.5 Ton
AR 823 - 200	Suitable for Shopping Malls, Hospitals/ Flat top surfaced.	200	210	65	380	Mill Finish Alu.	± 30	30 Ton 6.5 Ton
AR 823 - 202	Suitable for Shopping Malls, Hospitals/ Flat top surfaced.	200	208	50	340	Mill Finish Alu.	± 30	9 Ton 3.5 Ton
AR 823 - 250	Suitable for Shopping Malls, Hospitals/ Flat top surfaced.	250	260	65	430	Mill Finish Alu.	± 45	30 Ton 6.5 Ton



» AR823-150

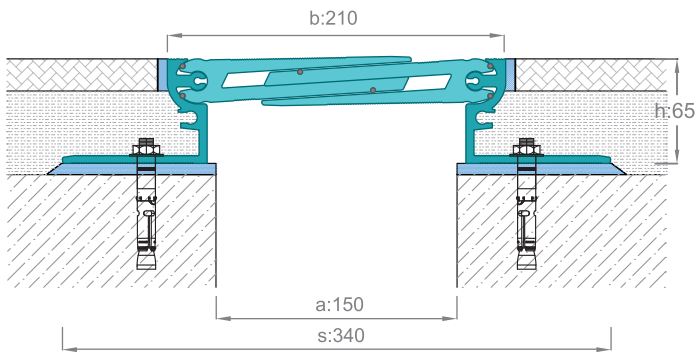

» AR823-150K

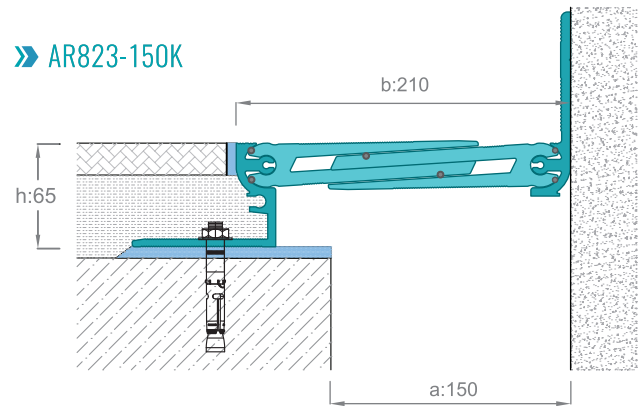

HEAVY DUTY
AND HYGIENIC
FLOOR PROFILES

» AR823-151

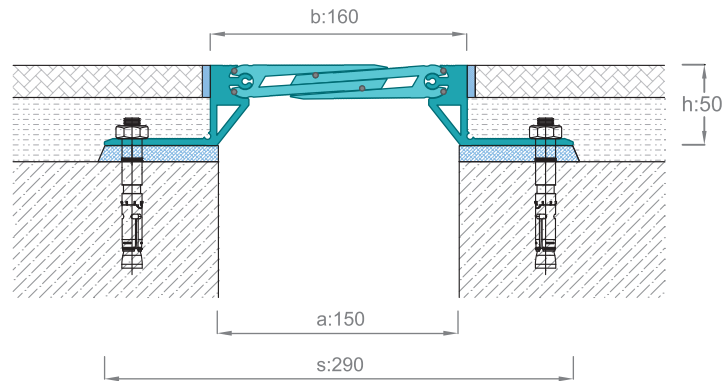

» AR820-100



» AR822-100



» AR823-100



» AR824-100



» AR825-100



» AR827-101

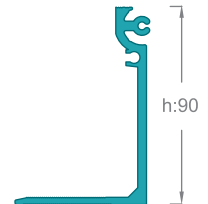

APPLICATIONS





» AR821-100

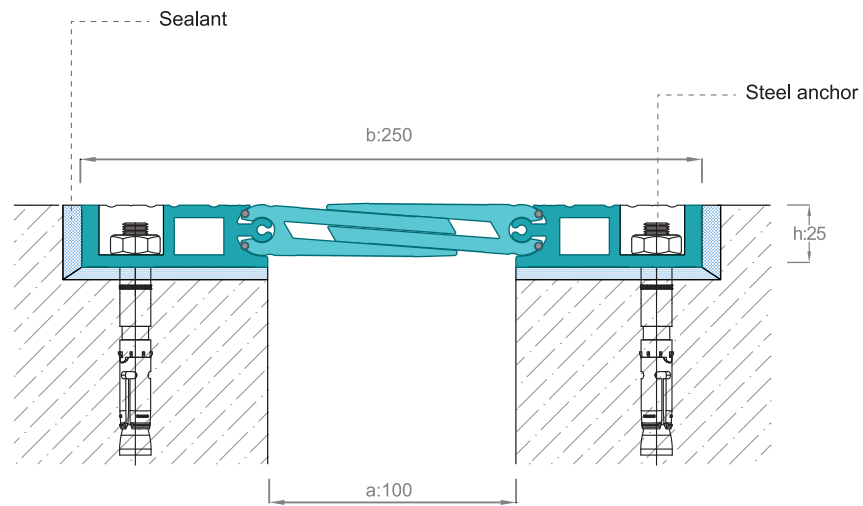

» AR821-150

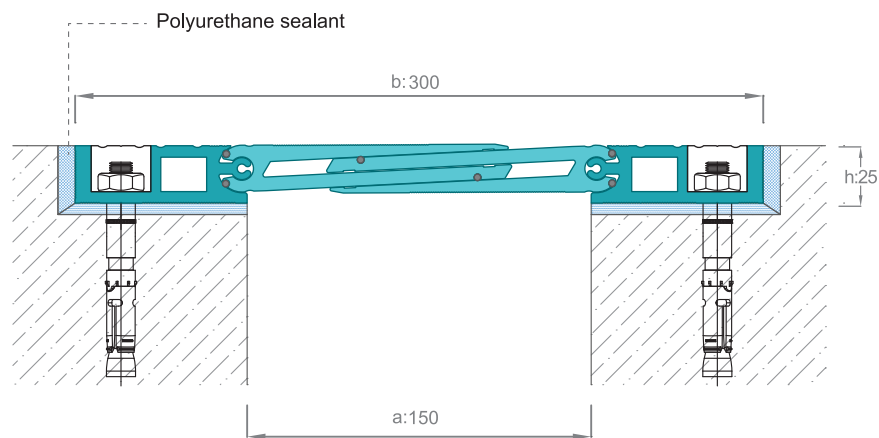

Special for no cover-floors. Easily applicable to the small gap ranges and resistant to heavy loads. At least, 30 mm x 80 mm gap dimensions are required to assemble these profiles.

APPLICATIONS

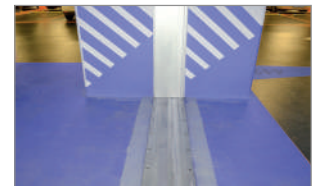

PRODUCT CODE	DESCRIPTION	JOINT WIDTH (a) mm	VISIBLE SURFACE (b) mm	PROFILE HEIGHT (h) mm	TOTAL WIDTH (s) mm	SURFACE	MOVEMENT CAPACITY mm	LOAD CAPACITY
AR 821 - 100	Suitable for industrial structures and carparks	100	250	25	250	Mill Finish Alu.	± 20	30 Ton 6,5 Ton
AR 821 - 150	Suitable for industrial structures and carparks	150	300	25	300	Mill Finish Alu.	± 25	30 Ton 6,5 Ton
AR 821 - 200	Suitable for industrial structures and carparks	200	380	26	380	Mill Finish Alu.	± 35	15 Ton 3,5 Ton

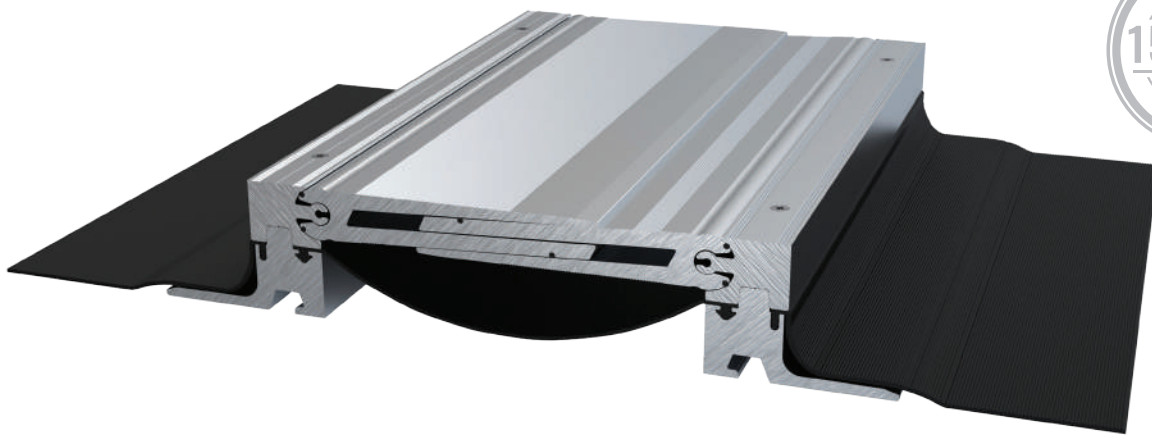

HEAVY DUTY
AND HYGIENIC
FLOOR PROFILES

» AR835-150

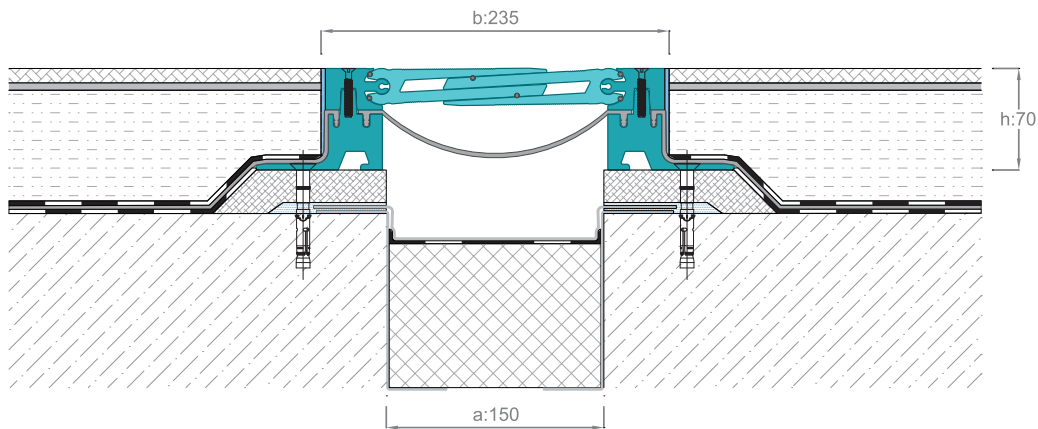

» AR835-200

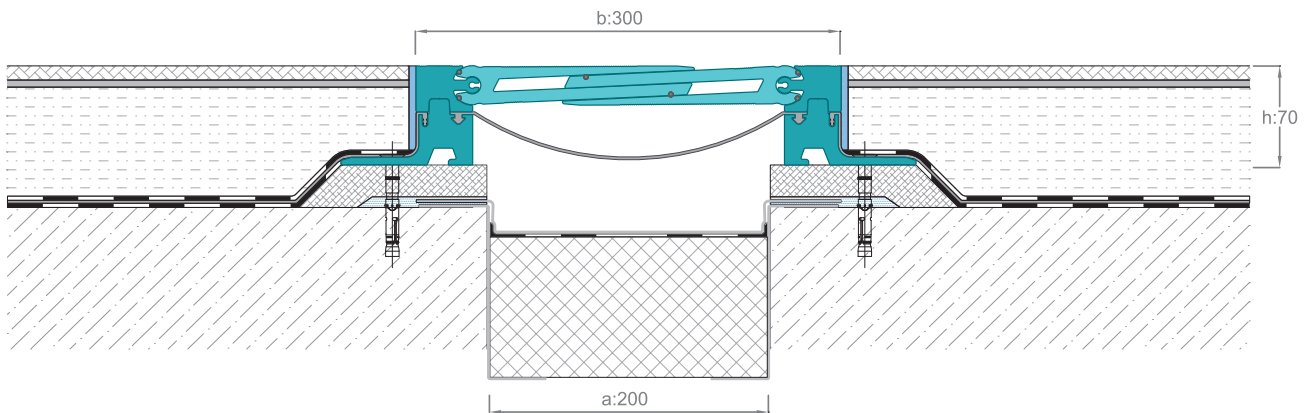

AR 835 series are multi-purpose floor expansion joint profiles. Hygienic design and optional removable waterproofing parts are resistant to heavy loads. It is preferred in airports, shopping malls, hospitals and wet areas.



PRODUCT CODE	DESCRIPTION	JOINT WIDTH (a) mm	VISIBLE SURFACE (b) mm	PROFILE HEIGHT (h) mm	TOTAL WIDTH (s) mm	SURFACE	MOVEMENT CAPACITY mm	LOAD CAPACITY
AR 835 - 150	Suitable for Shopping Malls, Hospitals/ Waterproofed	150	235	70	330	Mill Finish Alu.	+50/-30	30 Ton 7 Ton
AR 835 - 200	Suitable for Shopping Malls, Hospitals/ Waterproofed	200	300	70	406	Mill Finish Alu.	± 50	30 Ton 7 Ton
AR 835 - 250	Suitable for Shopping Malls, Hospitals/ Waterproofed	250	350	70	456	Mill Finish Alu.	± 50	16 Ton 3.5 Ton

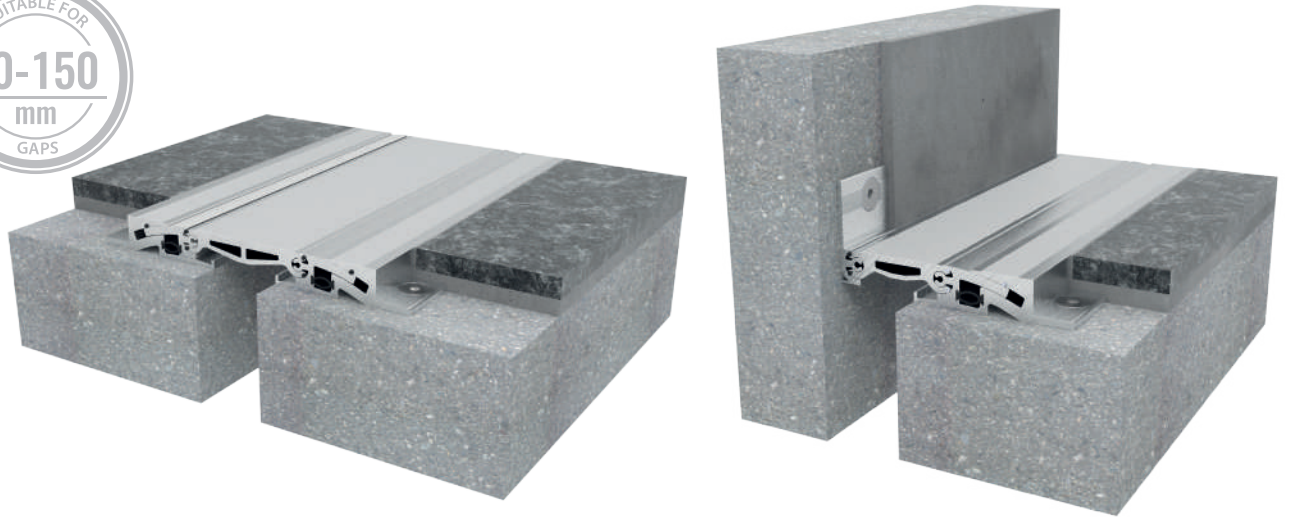



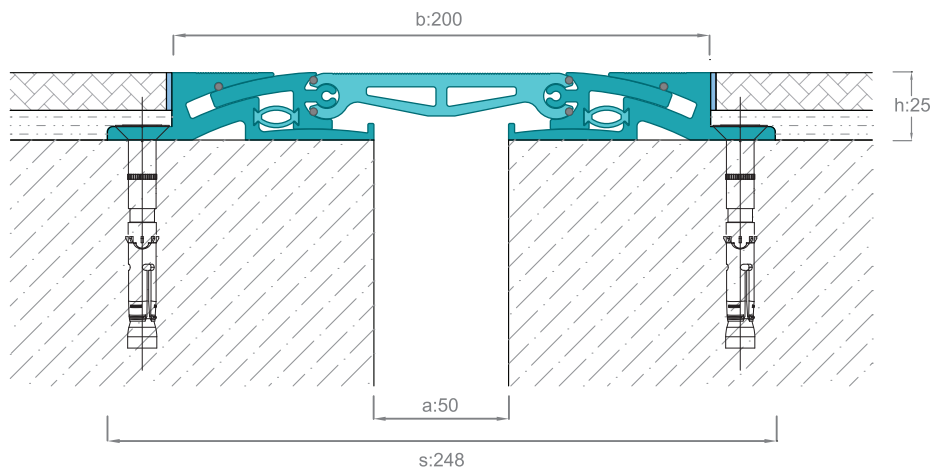

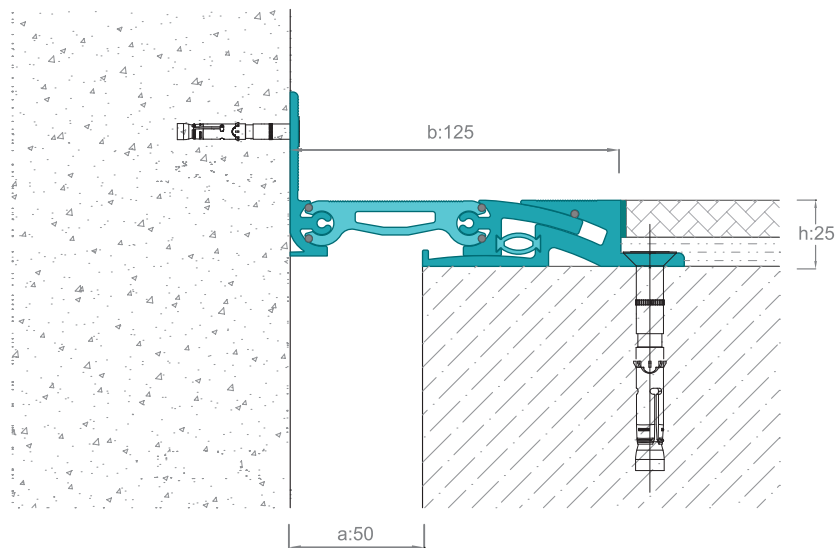

» AR841-050



» AR841-050K



Fully Aluminium top surfaced Expansion Joint profiles are resistant to heavy loads. Movable in three dimensional directions and have non-slip surface.

PRODUCT CODE	DESCRIPTION	JOINT WIDTH (a) mm	VISIBLE SURFACE (b) mm	PROFILE HEIGHT (h) mm	TOTAL WIDTH (s) mm	SURFACE	MOVEMENT CAPACITY mm	LOAD CAPACITY
AR 841 - 050	Suitable for intense vehicle traffic/ Alu. top surfaced.	50	200	25	248	Mill Finish Alu.	± 20	60 Ton  9 Ton 
AR 841 - 100	Suitable for intense vehicle traffic/ Alu. top surfaced.	100	250	25	298	Mill Finish Alu.	± 20	60 Ton  9 Ton 
AR 841 - 150	Suitable for intense vehicle traffic/ Alu. top surfaced.	150	300	25	348	Mill Finish Alu.	± 20	60 Ton  9 Ton 



» AR841-100

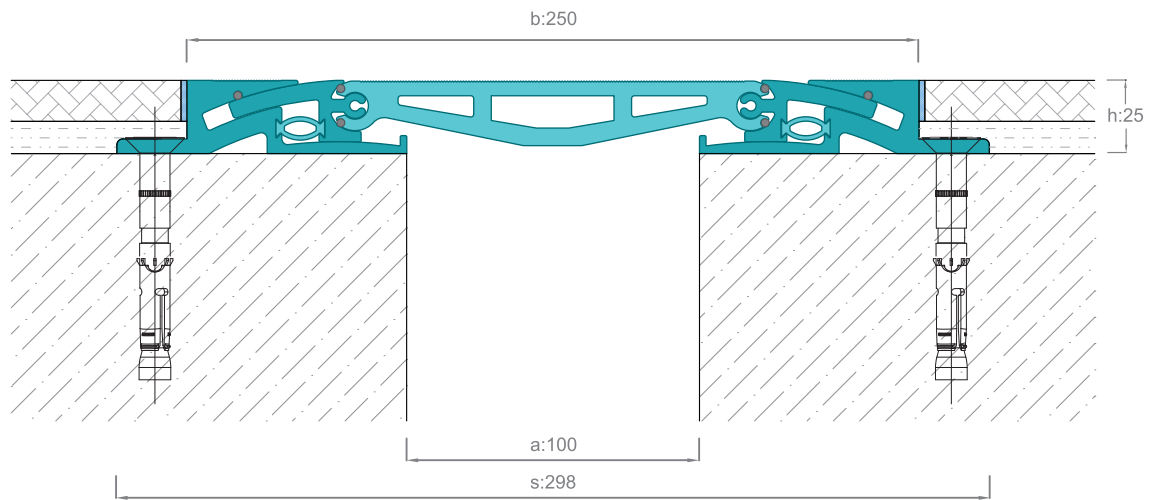

» AR841-100K

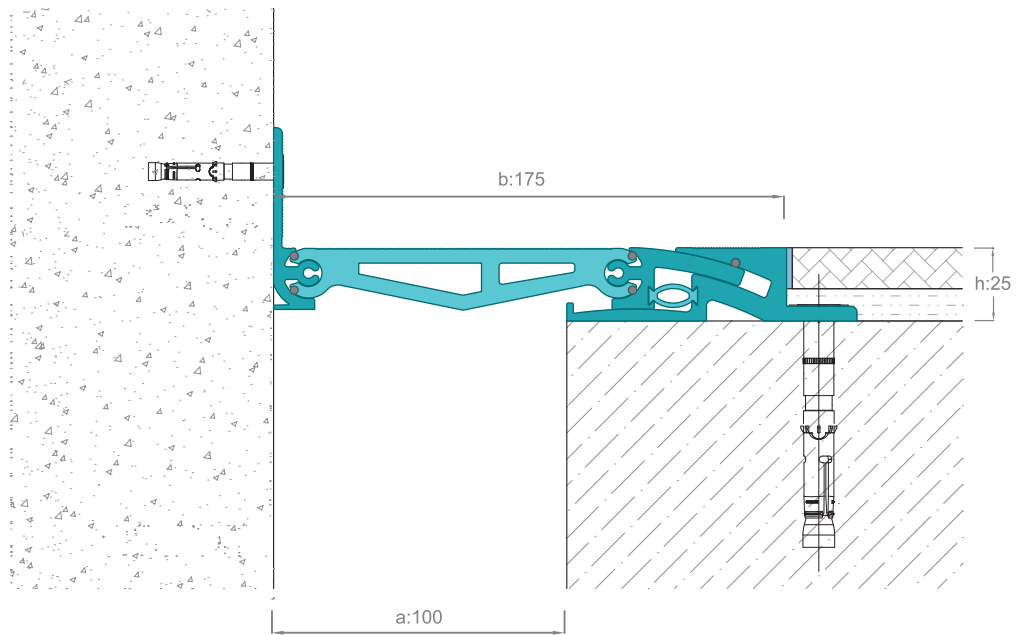

HEAVY DUTY
AND HYGIENIC
FLOOR PROFILES

APPLICATIONS



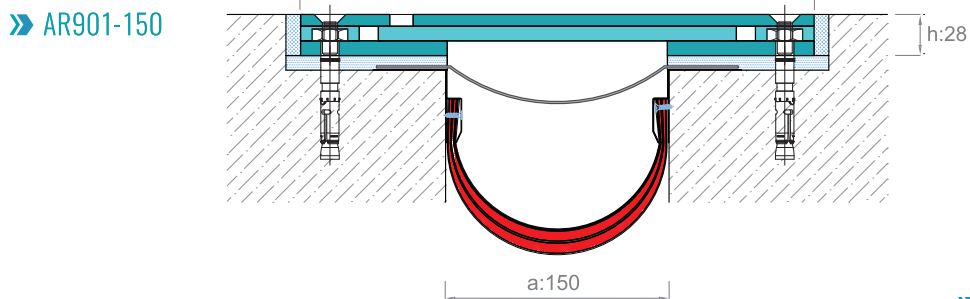
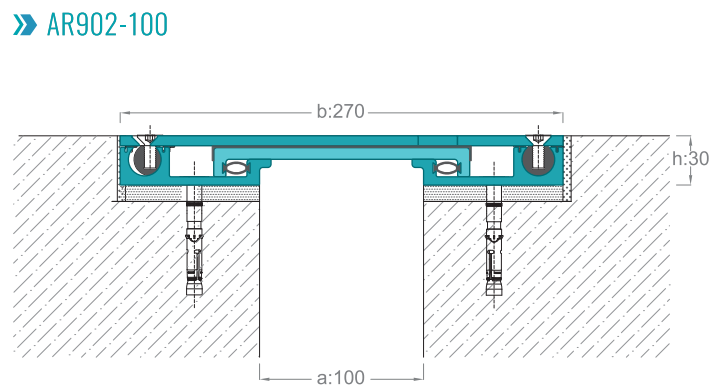
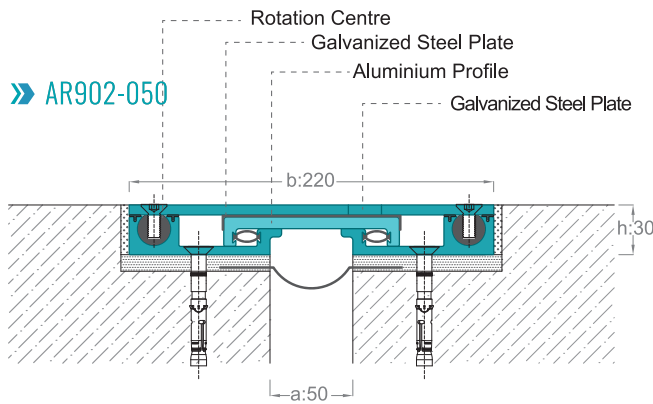
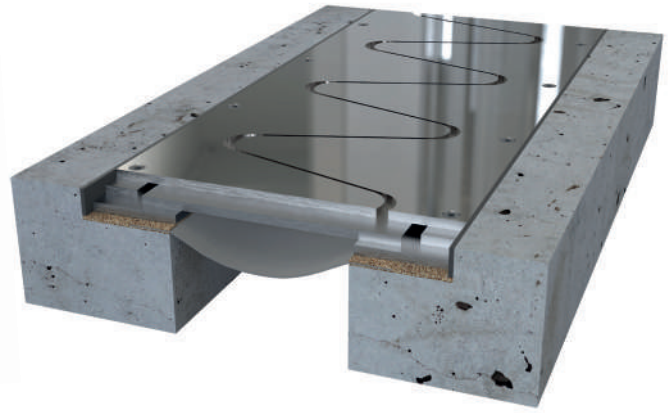

» CORNER APPLICATION

Specially designed to resist forklift loads and used in industrial structures with features of linearly curved design and steel body. Manufactured as dip galvanized and steel type. T, + joining details are also available.



PRODUCT CODE	DESCRIPTION	JOINT WIDTH (a) mm	VISIBLE SURFACE (b) mm	PROFILE HEIGHT (h) mm	TOTAL WIDTH (s) mm	SURFACE	MOVEMENT CAPACITY mm	LOAD CAPACITY
AR 902 - 050	Alu. bottom part+ Galvanized top surface	50	220	30	220	Galvanized	± 20	60 Ton 9 Ton
AR 902 - 051	Alu. bottom part+ Stainless steel top surface	50	220	30	220	Stainless Steel	± 20	60 Ton 9 Ton
AR 902 - 052	Alu. bottom part+ Aluminium top surface	50	220	30	220	Aluminium	± 20	60 Ton 9 Ton
AR 901 - 050	Steel bottom part+ Galvanized top surface	50	200	28	200	Galvanized	± 10	60 Ton 9 Ton
AR 902 - 100	Alu. bottom part+ Galvanized top surface	100	270	30	270	Galvanized	± 25	60 Ton 9 Ton
AR 902 - 101	Alu. bottom part+ Stainless steel top surface	100	270	30	270	Stainless Steel	± 25	60 Ton 9 Ton
AR 902 - 102	Alu. bottom part+ Aluminium top surface	100	270	30	270	Aluminium	± 25	60 Ton 9 Ton
AR 901 - 100	Steel bottom part+ Galvanized top surface	100	300	28	300	Galvanized	± 10	60 Ton 9 Ton
AR 902 - 150	Alu. bottom part+ Galvanized top surface	150	400	30	400	Galvanized	+30/-20	60 Ton 9 Ton
AR 902 - 151	Alu. bottom part+ Stainless steel top surface	150	400	30	400	Stainless Steel	+30/-20	60 Ton 9 Ton
AR 902 - 152	Alu. bottom part+ Aluminium top surface	150	400	30	400	Aluminium	+30/-20	60 Ton 9 Ton
AR 901 - 150	Steel bottom part+ Galvanized top surface	150	350	28	350	Galvanized	± 10	60 Ton 9 Ton
AR 901 - 200	Steel bottom part+ Galvanized top surface	200	400	28	400	Galvanized	± 10	60 Ton 9 Ton

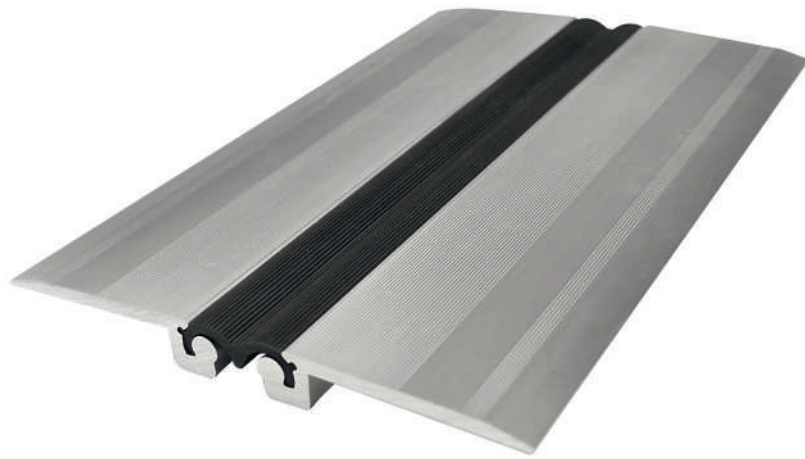

» AR753-050

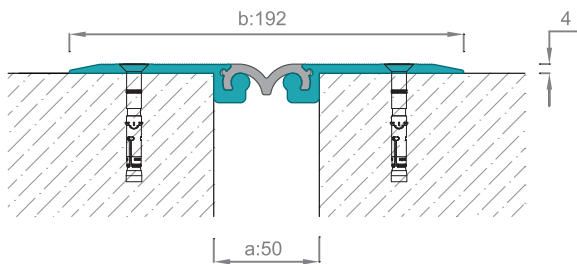

» AR753-050K

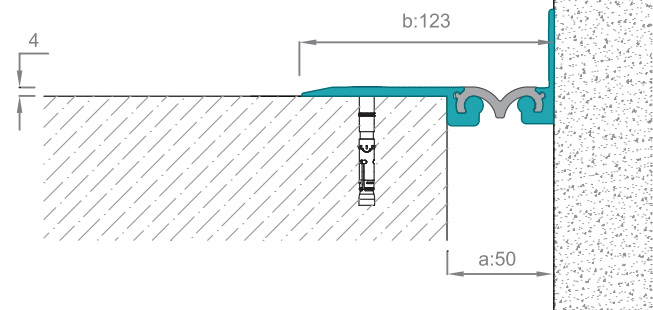

» AR773-100

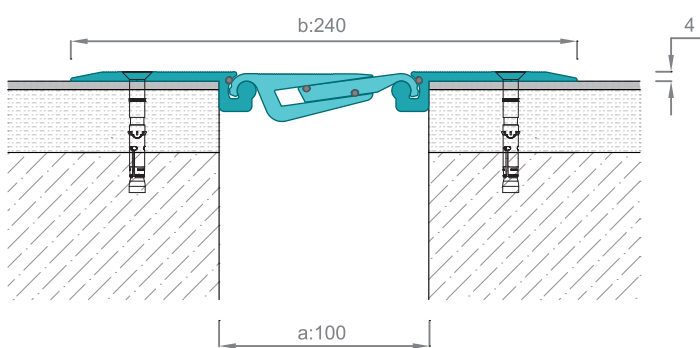

» AR773-100K

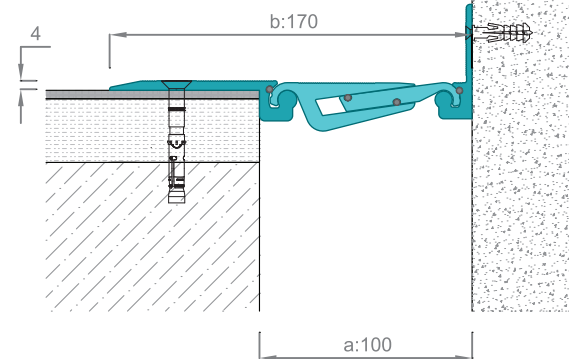

HEAVY DUTY
AND HYGIENIC
FLOOR PROFILES

APPLICATIONS

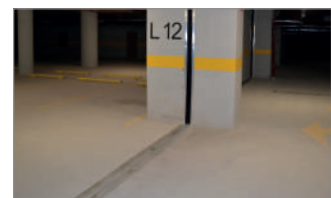

Surface mounted floor profiles are resistant to light vehicle traffic.
Can be applied on finished floor covers such as gross concrete floors.
Assembled to the floor with steel anchors.

PRODUCT CODE	DESCRIPTION	JOINT WIDTH (a) mm	VISIBLE SURFACE (b) mm	PROFILE HEIGHT (h) mm	TOTAL WIDTH (s) mm	SURFACE	MOVEMENT CAPACITY mm	LOAD CAPACITY
AR 753 - 050	Suitable for carpark/countersink holed	50	192	14	192	Mill Finish Alu.+TPE	± 10	9 Ton 5 Ton
AR 763 - 080	Suitable for carpark/countersink holed	80	220	14	220	Mill Finish Alu.	± 10	9 Ton 3.5 Ton
AR 773 - 100	Suitable for carpark/countersink holed	100	240	14	240	Mill Finish Alu.	± 12	6 Ton 1.5 Ton



» AR883-050

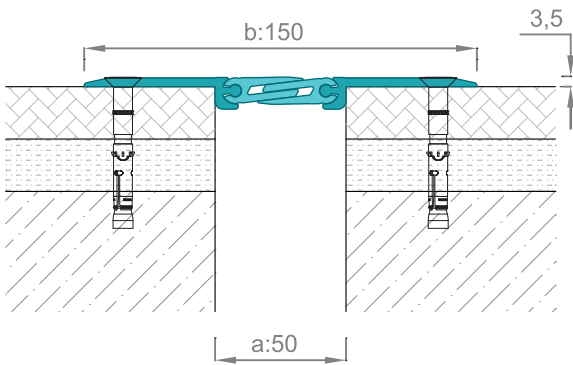

» AR883-050K

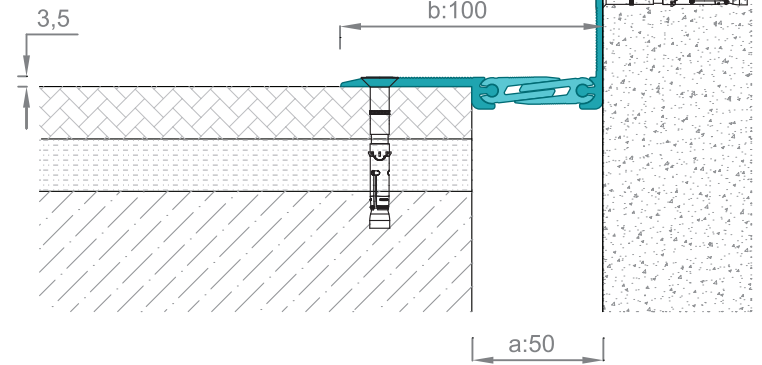

» AR883-100

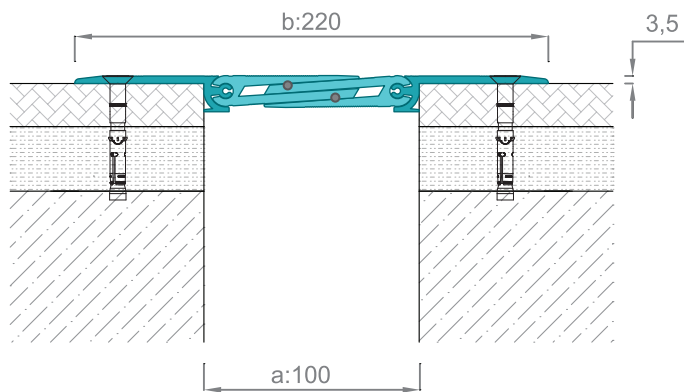

» AR883-100K

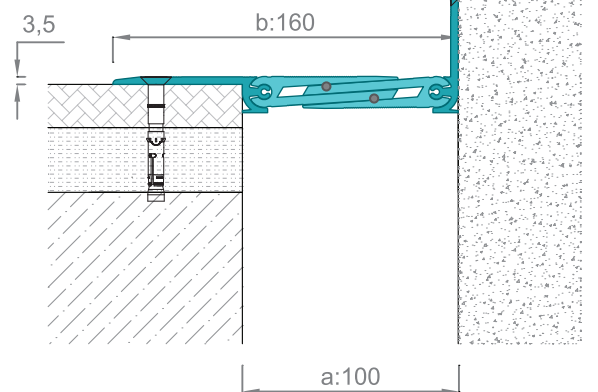

Surface Mounted floor profiles have the capacity to move in three dimensional directions.



PRODUCT CODE	DESCRIPTION	JOINT WIDTH (a) mm	VISIBLE SURFACE (b) mm	PROFILE HEIGHT (h) mm	TOTAL WIDTH (s) mm	SURFACE	MOVEMENT CAPACITY mm	LOAD CAPACITY
AR 883 - 050	Suitable for carparks/countersink holed	50	150	10	150	Mill Finish Alu.	± 5	Pedestrian Load 1.5 Ton
AR 883 - 100	Suitable for carparks/countersink holed	100	220	13	220	Mill Finish Alu.	± 12	6 Ton 1.5 Ton
AR 883 - 150	Suitable for carparks/countersink holed	150	300	20	300	Mill Finish Alu.	± 25	3.5 Ton 1.5 Ton
AR 883 - 200	Suitable for carparks/countersink holed	200	350	20	350	Mill Finish Alu.	+40/-15	3.5 Ton 2 Ton

seismic expansion joint profiles

SEISMIC
EXPANSION JOINT
PROFILES

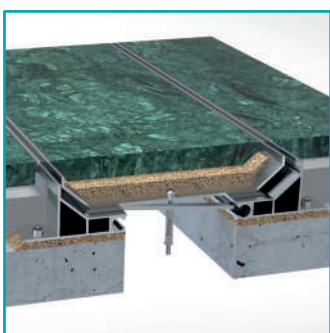
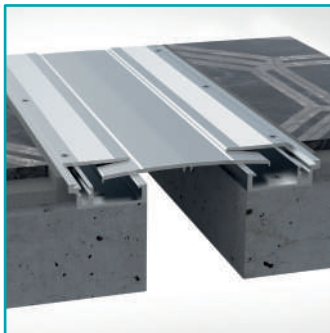
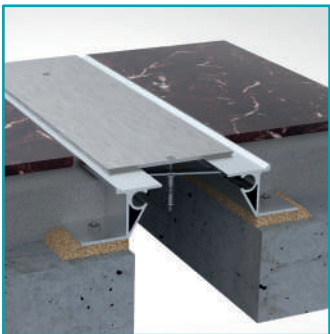
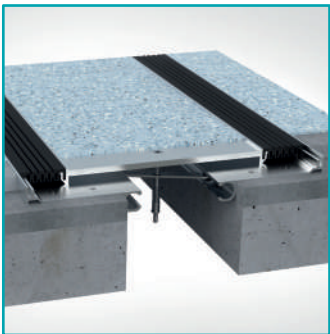
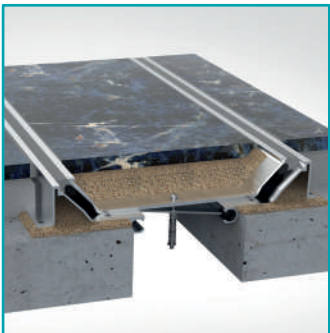



» AR802-100

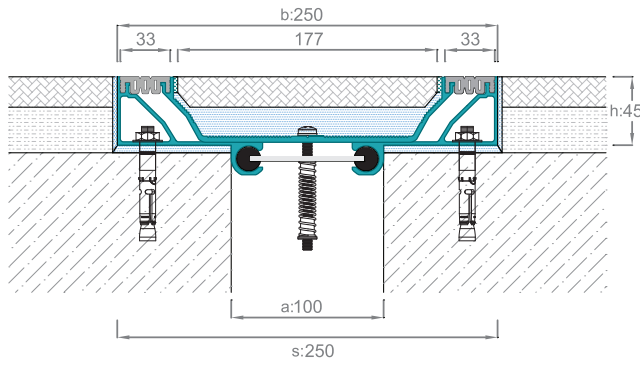

» AR802-150

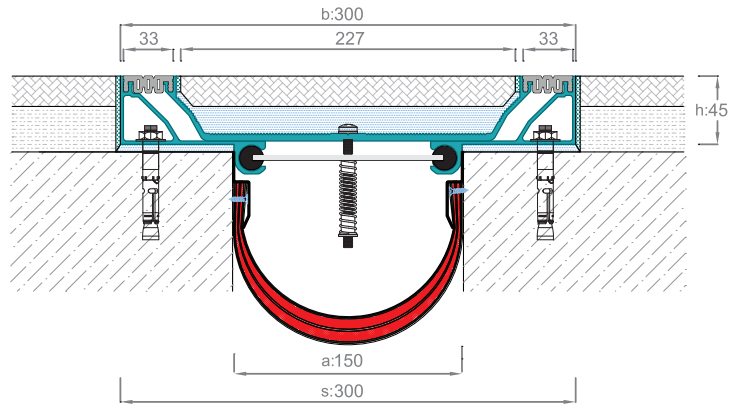

» AR802-150K

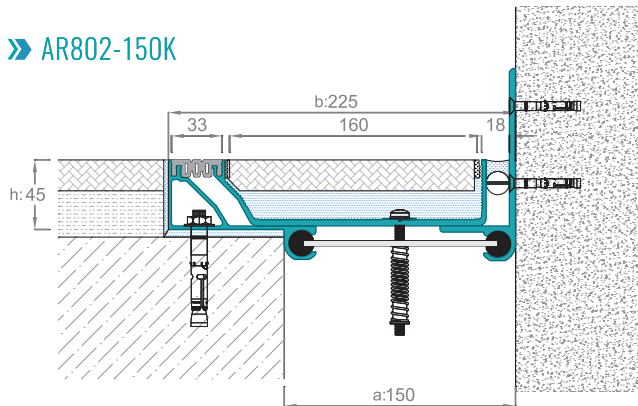

Suitable for low levelled floor covers such as PVC and epoxy covers. High movable capacity and large TPE gasketed profiles are usable for floors. (Please refer to page 62 for wall and ceiling options.)



PRODUCT CODE	DESCRIPTION	JOINT WIDTH (a) mm	VISIBLE SURFACE (b) mm	PROFILE HEIGHT (h) mm	TOTAL WIDTH (s) mm	SURFACE	MOVEMENT CAPACITY mm	LOAD CAPACITY
AR802-100	Seismic floor expansion joint profile with gasket	100	250	45	250	Mill Finish Alu.+TPE+Floor Covers	± 50	Pedestrian Traffic ↑ Cleaning Machine ↓
AR802-150	Seismic floor expansion joint profile with gasket	150	300	45	300	Mill Finish Alu.+TPE+Floor Covers	± 70	Pedestrian Traffic ↑ Cleaning Machine ↓
AR802-200	Seismic floor expansion joint profile with gasket	200	400	45	400	Mill Finish Alu.+TPE+Floor Covers	+100/-80	Pedestrian Traffic ↑ Cleaning Machine ↓
AR802-250	Seismic floor expansion joint profile with gasket	250	480	60	480	Mill Finish Alu.+TPE+Floor Covers	± 125	Pedestrian Traffic ↑ Cleaning Machine ↓
AR802-300	Seismic floor expansion joint profile with gasket	300	600	60	600	Mill Finish Alu.+TPE+Floor Covers	± 150	Pedestrian Traffic ↑ Cleaning Machine ↓
AR802-350	Seismic floor expansion joint profile with gasket	350	650	60	650	Mill Finish Alu.+TPE+Floor Covers	± 175	Pedestrian Traffic ↑ Cleaning Machine ↓
AR802-400	Seismic floor expansion joint profile with gasket	400	700	60	700	Mill Finish Alu.+TPE+Floor Covers	+175/-200	Pedestrian Traffic ↑ Cleaning Machine ↓
AR802-450	Seismic floor expansion joint profile with gasket	450	750	60	750	Mill Finish Alu.+TPE+Floor Covers	+175/-225	Pedestrian Traffic ↑ Cleaning Machine ↓
AR802-500	Seismic floor expansion joint profile with gasket	500	800	60	800	Mill Finish Alu.+TPE+Floor Covers	+175/-250	Pedestrian Traffic ↑ Cleaning Machine ↓



» AR803-100

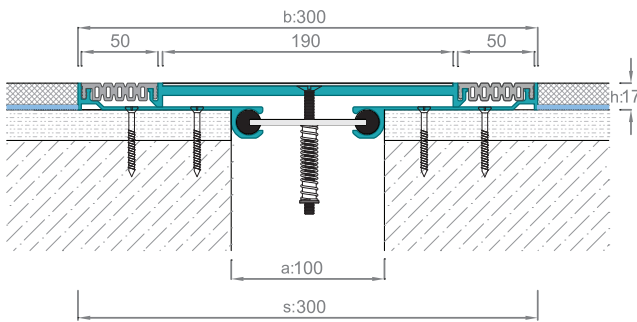

» AR803-150

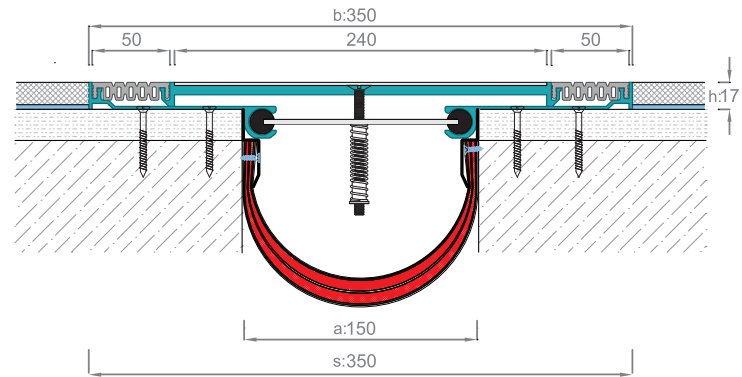

» AR803-150K

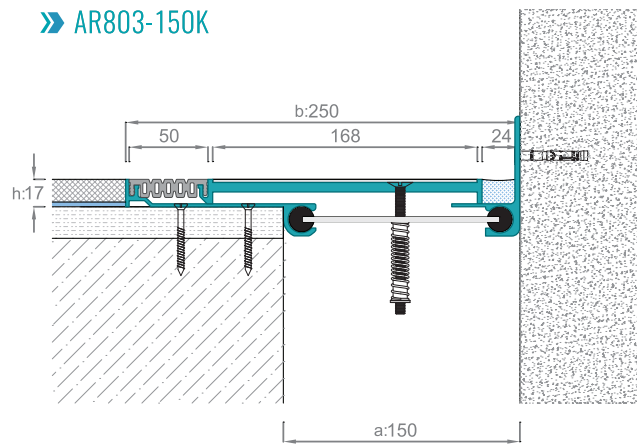

SEISMIC
EXPANSION JOINT
PROFILES

Suitable for low levelled floor covers such as PVC and epoxy covers. High movable capacity and large TPE gasketed profiles are usable for floors. (Please refer to page 62 for wall and ceiling options.)



PRODUCT CODE	DESCRIPTION	JOINT WIDTH (a) mm	VISIBLE SURFACE (b) mm	PROFILE HEIGHT (h) mm	TOTAL WIDTH (s) mm	SURFACE	MOVEMENT CAPACITY mm	LOAD CAPACITY
AR803-100	Suitable for PVC floor cover/ gasketed	100	300	17	300	Mill Finish Alu.+ TPE+ Cover	± 50	Pedestrian Traffic Cleaning Machine
AR803-150	Suitable for PVC floor cover/ gasketed	150	350	17	350	Mill Finish Alu.+ TPE+ Cover	± 75	Pedestrian Traffic Cleaning Machine
AR803-200	Suitable for PVC floor cover/ gasketed	200	400	17	400	Mill Finish Alu.+ TPE+ Cover	±100	Pedestrian Traffic Cleaning Machine

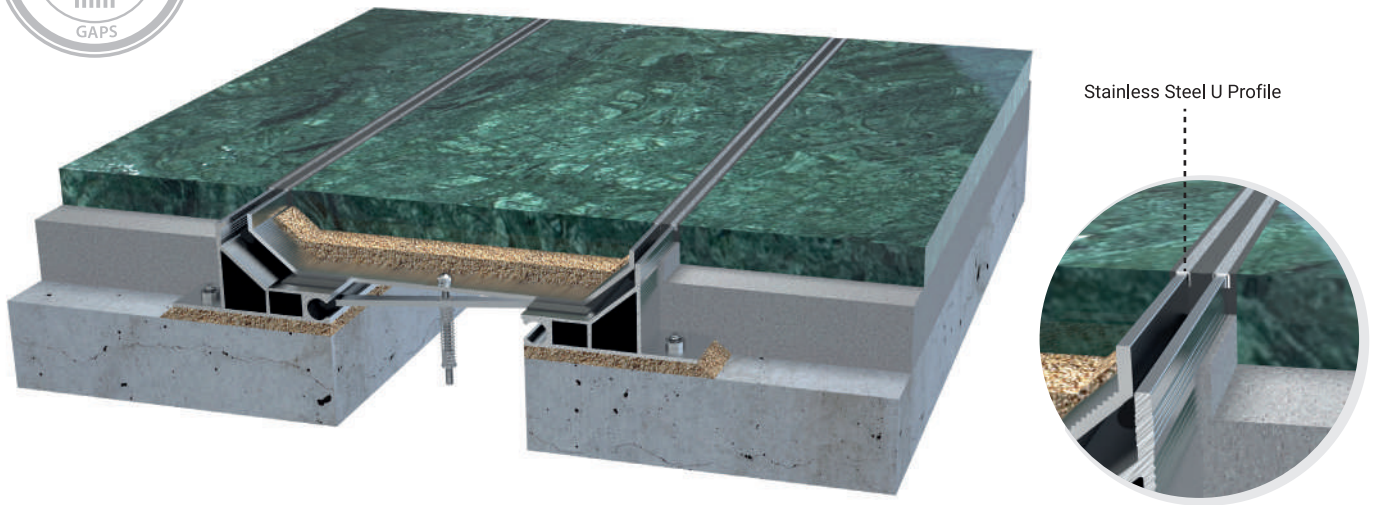

» AR804-100

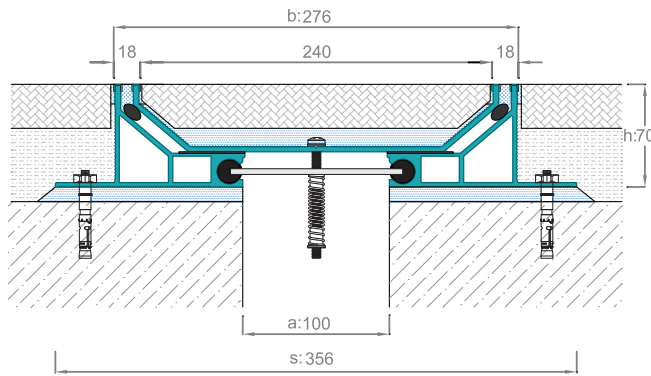

» AR804-150

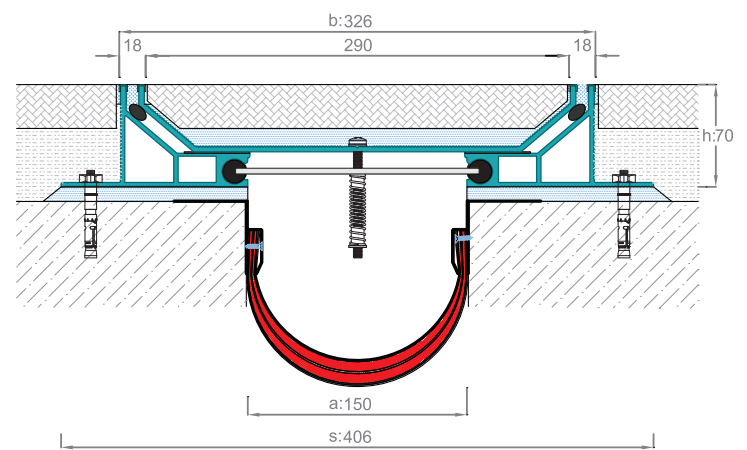

» AR804-150K

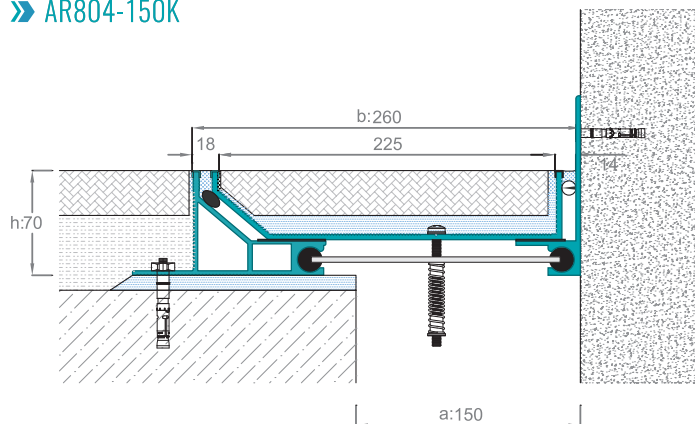

Designed to apply on large gaps and provide small visible portions. Even though, AR 803 series has less movement capacity compared to other seismic profiles, the decorative design still makes it special to be preferred. (Please refer to page 63 for wall and ceiling options.)



PRODUCT CODE	DESCRIPTION	JOINT WIDTH (a) mm	VISIBLE SURFACE (b) mm	PROFILE HEIGHT (h) mm	TOTAL WIDTH (s) mm	SURFACE	MOVEMENT CAPACITY mm	LOAD CAPACITY
AR 804 - 100	Stainless Steel top surface + sealant application	100	276	70	356	Stainless Steel + Sealant+ Floor Cover	± 50	Pedestrian Traffic Cleaning Machine
AR 804 - 150	Stainless Steel top surface + sealant application	150	326	70	406	Stainless Steel + Sealant+ Floor Cover	± 75	Pedestrian Traffic Cleaning Machine
AR 804 - 200	Stainless Steel top surface + sealant application	200	490	70	571	Stainless Steel + Sealant+ Floor Cover	± 75	Pedestrian Traffic Cleaning Machine
AR 804 - 250	Stainless Steel top surface + sealant application	250	540	70	621	Stainless Steel + Sealant+ Floor Cover	± 75	Pedestrian Traffic Cleaning Machine
AR 804 - 300	Stainless Steel top surface + sealant application	300	590	70	671	Stainless Steel + Sealant+ Floor Cover	± 75	Pedestrian Traffic Cleaning Machine

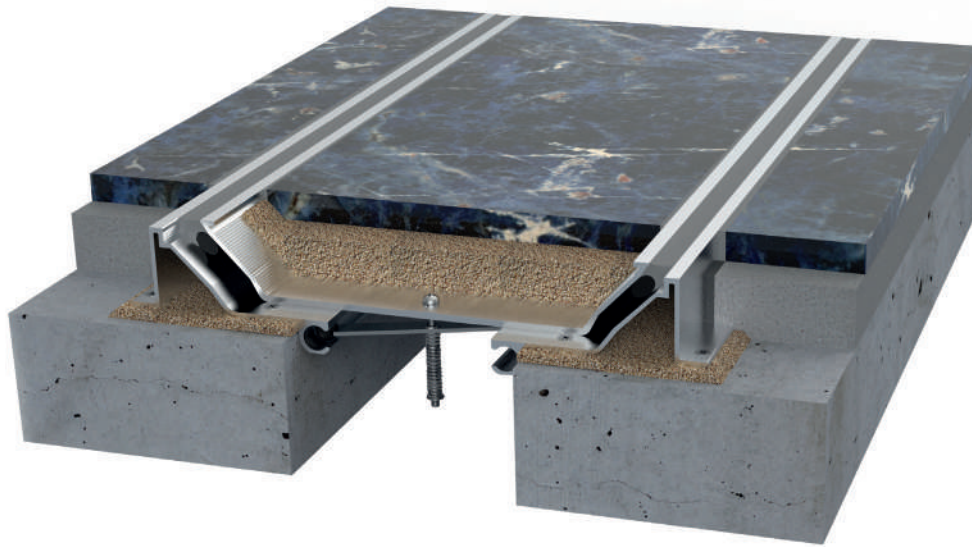

» AR806-100

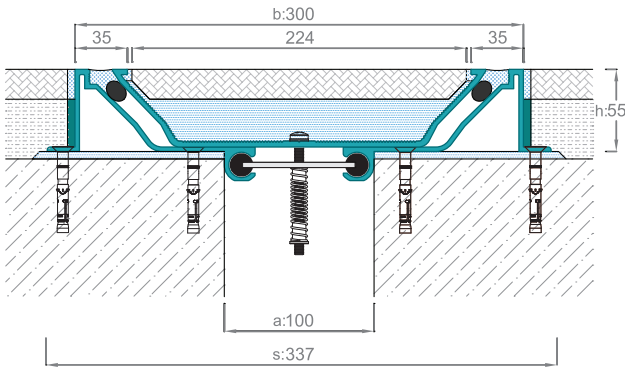

» AR806-150

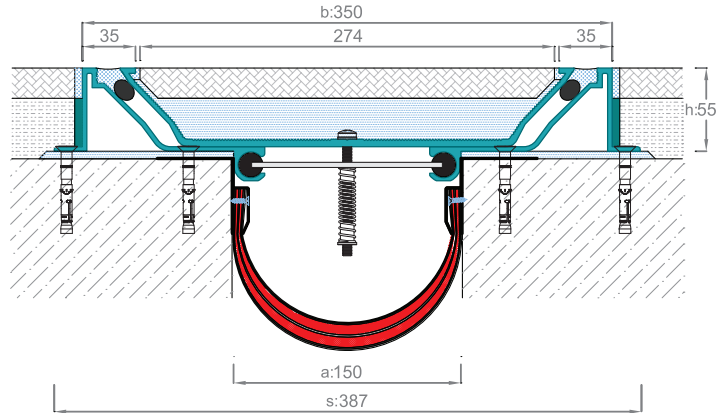

» AR806-150K

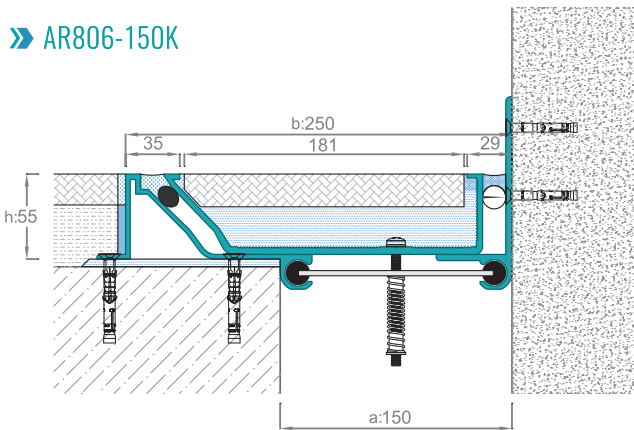

SEISMIC
EXPANSION JOINT
PROFILES

AR 806 series are economic and alternative options to Floor Seismic Expansion joint Profiles to have high movement capacity. They are applicable to large gaps with very narrow visible surface. Suitable for all flooring types. Epoxy filler used in the middle part to avoid any cracks or damages could occur to floor cover. (Please refer to page 64 for wall and ceiling options.)

APPLICATIONS

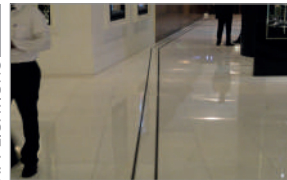

PRODUCT CODE	DESCRIPTION	JOINT WIDTH (a) mm	VISIBLE SURFACE (b) mm	PROFILE HEIGHT (h) mm	TOTAL WIDTH (s) mm	SURFACE	MOVEMENT CAPACITY mm	LOAD CAPACITY
AR 806 - 100	Sealant applied seismic floor profile	100	300	55	337	Mill Finish Alu.+Sealant+ Floor Cover	± 50	Pedestrian Traffic Cleaning Machine
AR 806 - 150	Sealant applied seismic floor profile	150	350	55	387	Mill Finish Alu.+Sealant+ Floor Cover	± 75	Pedestrian Traffic Cleaning Machine
AR 806 - 200	Sealant applied seismic floor profile	200	400	55	437	Mill Finish Alu.+Sealant+ Floor Cover	±100	Pedestrian Traffic Cleaning Machine
AR 806 - 250	Sealant applied seismic floor profile	250	550	65	587	Mill Finish Alu.+Sealant+ Floor Cover	±125	Pedestrian Traffic Cleaning Machine
AR 806 - 300	Sealant applied seismic floor profile	300	600	65	637	Mill Finish Alu.+Sealant+ Floor Cover	± 150	Pedestrian Traffic Cleaning Machine
AR 806 - 350	Sealant applied seismic floor profile	350	650	65	687	Mill Finish Alu.+Sealant+ Floor Cover	± 175	Pedestrian Traffic Cleaning Machine
AR 806 - 400	Sealant applied seismic floor profile	400	700	65	737	Mill Finish Alu.+Sealant+ Floor Cover	±200	Pedestrian Traffic Cleaning Machine
AR 806 - 450	Sealant applied seismic floor profile	450	750	65	787	Mill Finish Alu.+Sealant+ Floor Cover	±200	Pedestrian Traffic Cleaning Machine
AR 806 - 500	Sealant applied seismic floor profile	500	800	65	837	Mill Finish Alu.+Sealant+ Floor Cover	±200	Pedestrian Traffic Cleaning Machine

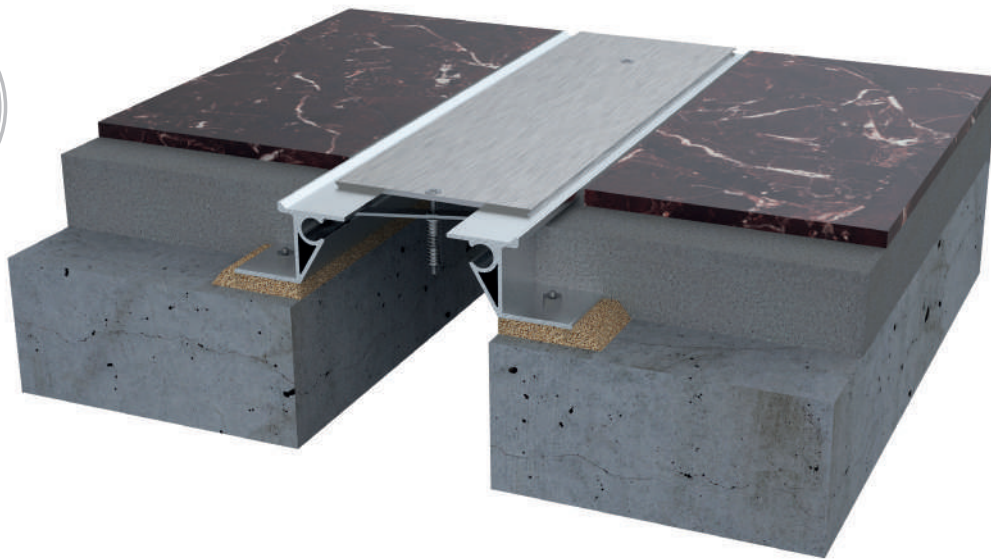

» AR813-100

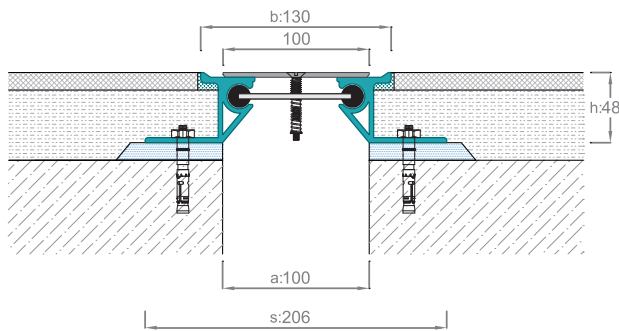

» AR813-150

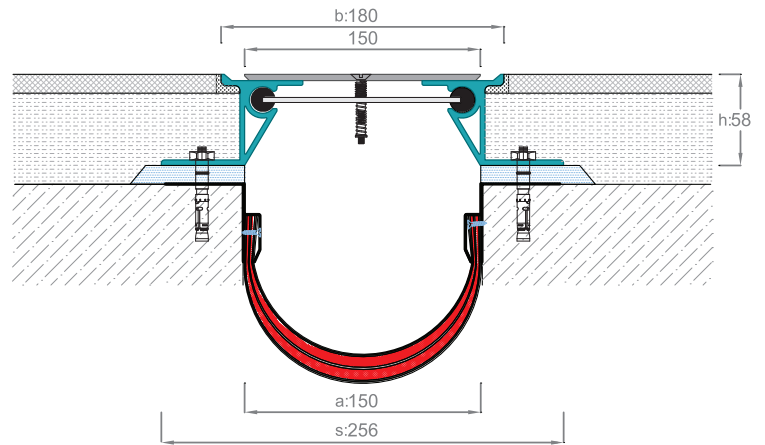

» AR813-150K

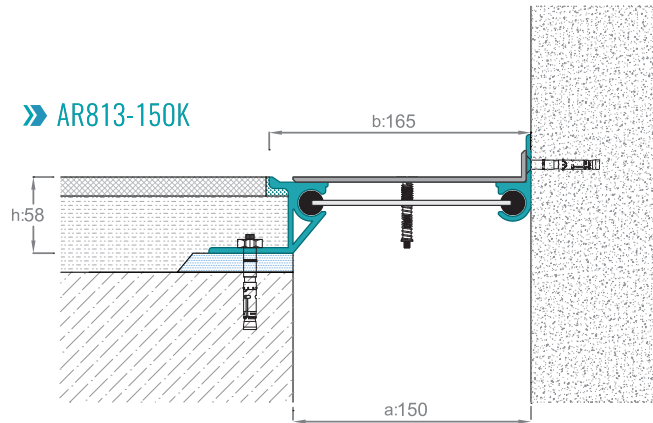

Hygienic and Decorative AR 813 series profiles are composed of aluminium bottom profile and stainless steel top plate. Especially used in metro stations, shopping centres and hospitals. (Please refer to page 65 for wall and ceiling options.)

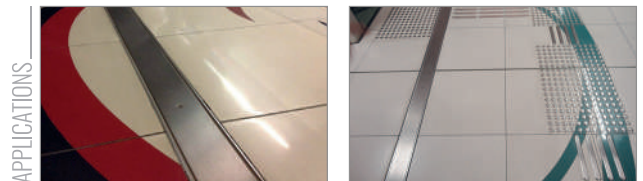

PRODUCT CODE	DESCRIPTION	JOINT WIDTH (a) mm	VISIBLE SURFACE (b) mm	PROFILE HEIGHT (h) mm	TOTAL WIDTH (s) mm	SURFACE	MOVEMENT CAPACITY mm	LOAD CAPACITY
AR 813 - 100	Stainless Steel top surface + Seismic floor profile	100	130	48	206	Mill Finish Alu.+ Stainless Steel	+40/-50	3,5 Ton
AR 813 - 150	Stainless Steel top surface + Seismic floor profile	150	180	58	256	Mill Finish Alu.+ Stainless Steel	+60/-60	3,5 Ton
AR 813 - 200	Stainless Steel top surface + Seismic floor profile	200	230	58	306	Mill Finish Alu.+ Stainless Steel	+60/-100	3,5 Ton
AR 813 - 250	Stainless Steel top surface + Seismic floor profile	250	280	58	356	Mill Finish Alu.+ Stainless Steel	+60/-125	Pedestrian Traffic Cleaning Machine
AR 813 - 300	Stainless Steel top surface + Seismic floor profile	300	330	58	406	Mill Finish Alu.+ Stainless Steel	+60/-150	Pedestrian Traffic Cleaning Machine

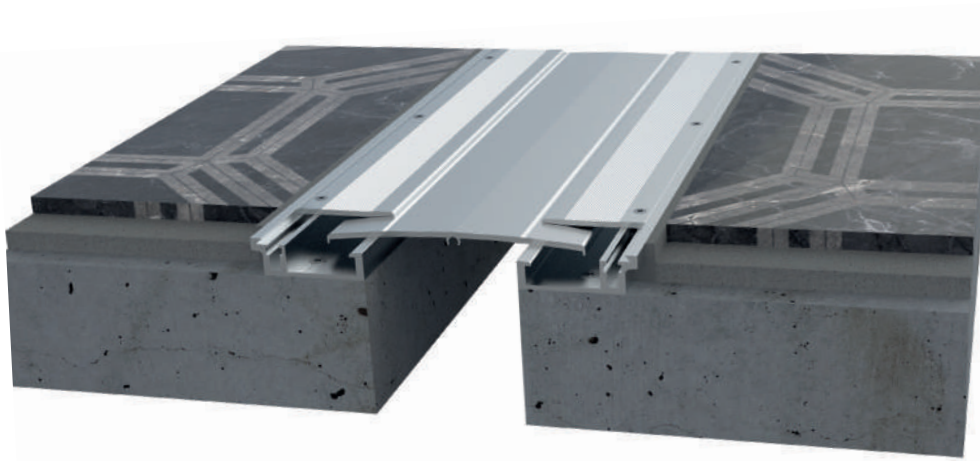

» AR851-050

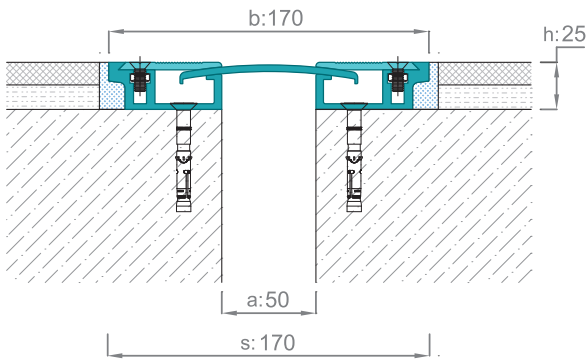

» AR851-100

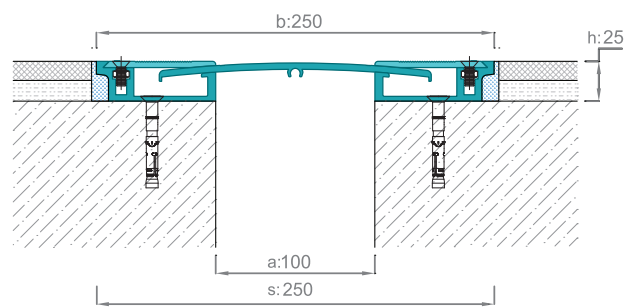

» AR851-150

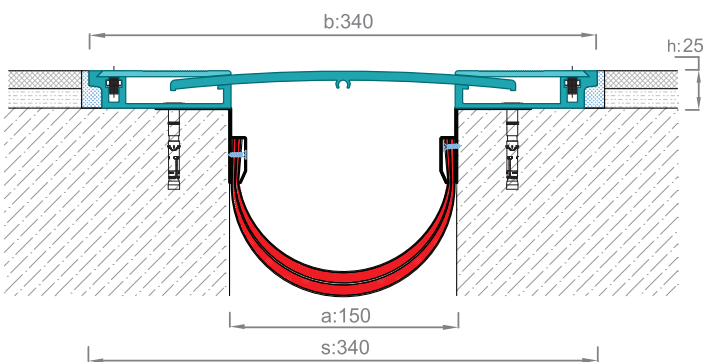

» AR851-100K

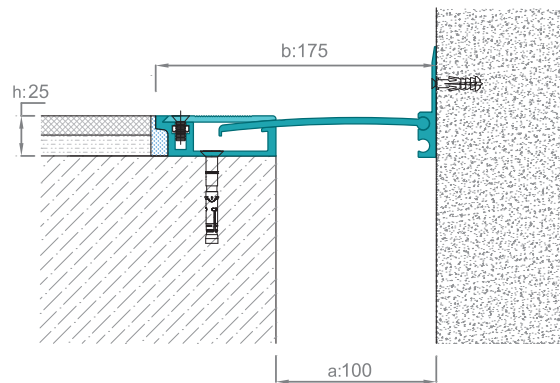

SEISMIC
EXPANSION JOINT
PROFILES

Seismic floor expansion joint profiles have the features of high movement capacity and resistant to heavy loads with completely aluminium top surface. (Please refer to page 66 for wall and ceiling options.)



APPLICATIONS

PRODUCT CODE	DESCRIPTION	JOINT WIDTH (a) mm	VISIBLE SURFACE (b) mm	PROFILE HEIGHT (h) mm	TOTAL WIDTH (s) mm	SURFACE	MOVEMENT CAPACITY mm	LOAD CAPACITY
AR851-050	Aluminium top surfaced Seismic floor profile	50	170	25	170	Mill Finish Alu.	± 25	3 Ton
AR851-100	Aluminium top surfaced Seismic floor profile	100	250	25	250	Mill Finish Alu.	+50/-30	2,5 Ton
AR851-101	Aluminium top surfaced Seismic floor profile	100	290	25	290	Mill Finish Alu.	±60	2,5 Ton
AR851-125	Aluminium top surfaced Seismic floor profile	125	330	25	330	Mill Finish Alu.	±60	2,5 Ton
AR851-150	Aluminium top surfaced Seismic floor profile	150	340	25	340	Mill Finish Alu.	±60	2,5 Ton
AR851-200	Aluminium top surfaced Seismic floor profile	200	390	25	390	Mill Finish Alu.	± 60	1,5 Ton Pedestrian Traffic

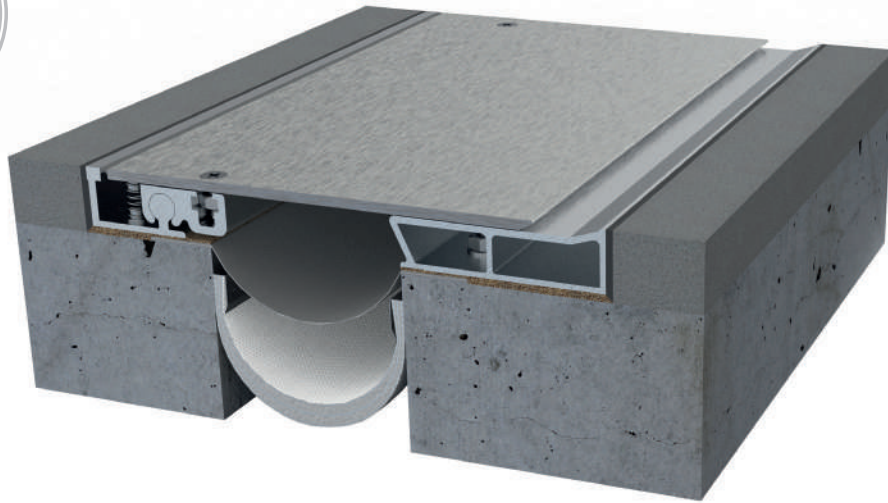

» AR931-150

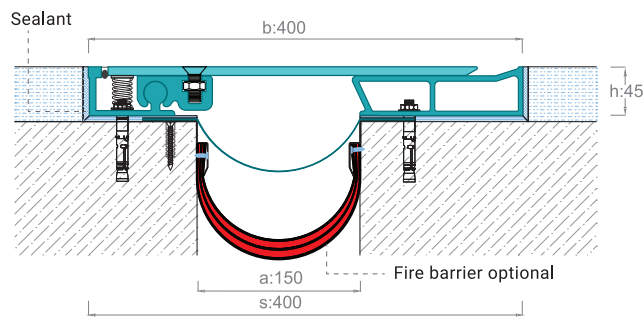

» AR931-200

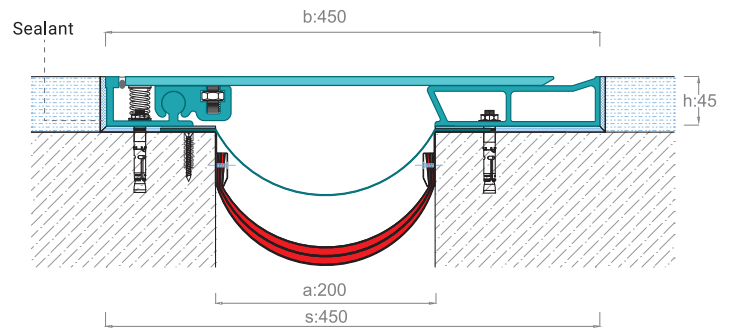

» AR931-150K

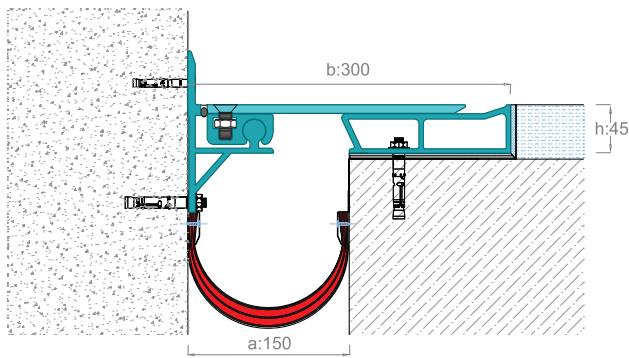

» AR931-200K

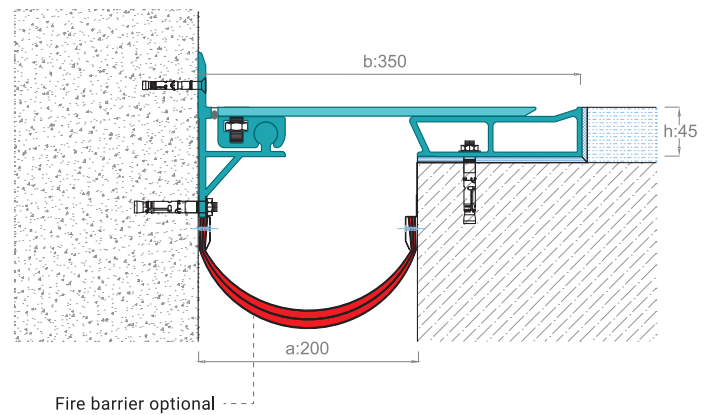

Flush mounted floor profiles are one sided articulated and have alternative top surface options made of galvanize steel and aluminium.

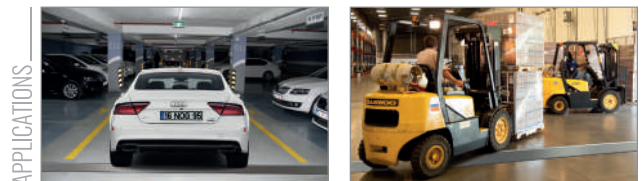

PRODUCT CODE	DESCRIPTION	JOINT WIDTH (a) mm	VISIBLE SURFACE (b) mm	PROFILE HEIGHT (h) mm	TOTAL WIDTH (s) mm	SURFACE	MOVEMENT CAPACITY mm	LOAD CAPACITY
AR931-100	Suitable for Industrial structures and carparks	100	350	45	350	Mill Finish Alu.	± 50	30 Ton 6.5 Ton
AR931-150	Suitable for Industrial structures and carparks	150	400	45	400	Mill Finish Alu.	±75	30 Ton 6.5 Ton
AR931-200	Suitable for Industrial structures and carparks	200	450	45	450	Mill Finish Alu.	±100	15 Ton 3.5 Ton
AR931-250	Suitable for Industrial structures and carparks	250	550	45	550	Mill Finish Alu.+Galvanized Steel	±100	15 Ton 3.5 Ton
AR931-300	Suitable for Industrial structures and carparks	300	600	45	600	Mill Finish Alu.+Galvanized Steel	±100	15 Ton 3.5 Ton

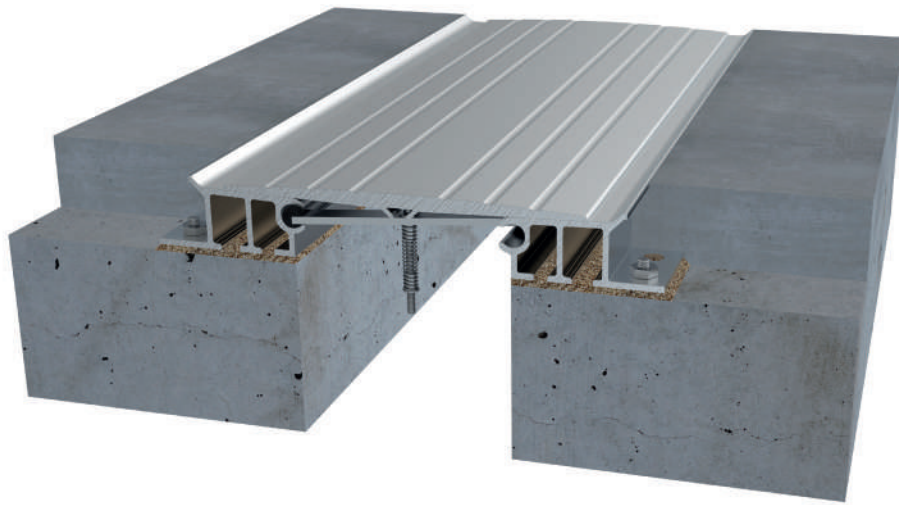

» AR932-100

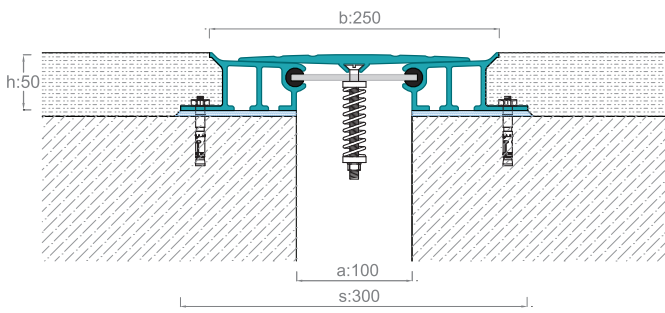

» AR932-150

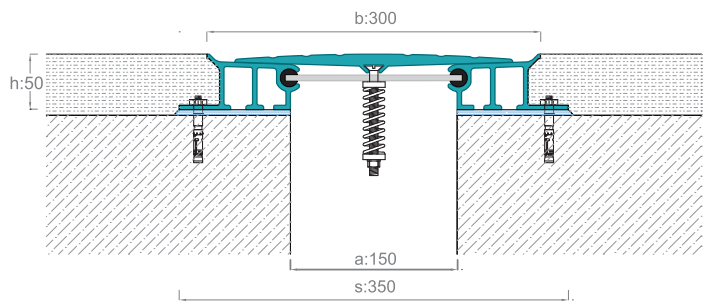

» AR932-100 K

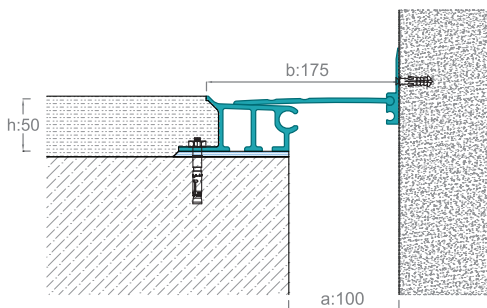

» AR932-150 K

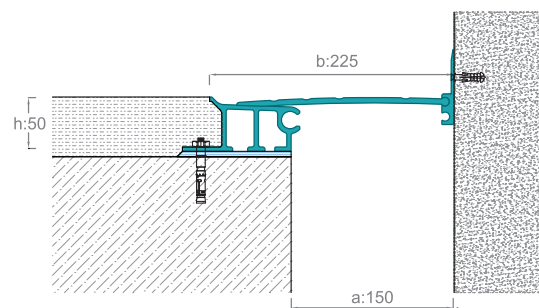

SEISMIC
EXPANSION JOINT
PROFILES

AR 932 series are composed of large Aluminium top surface and have the capacity to move in 3 dimensional directions. (Please refer to page 66 for wall and ceiling options.)

APPLICATIONS



PRODUCT CODE	DESCRIPTION	JOINT WIDTH (a) mm	VISIBLE SURFACE (b) mm	PROFILE HEIGHT (h) mm	TOTAL WIDTH (s) mm	SURFACE	MOVEMENT CAPACITY mm	LOAD CAPACITY
AR 932 - 100	High load capacity seismic profiles	100	250	50	300	Mill Finish Alu.	± 50	15 Ton
AR 932 - 150	High load capacity seismic profiles	150	300	50	350	Mill Finish Alu.	± 75	15 Ton
AR 932 - 200	High load capacity seismic profiles	200	350	50	400	Mill Finish Alu.	± 100	9 Ton

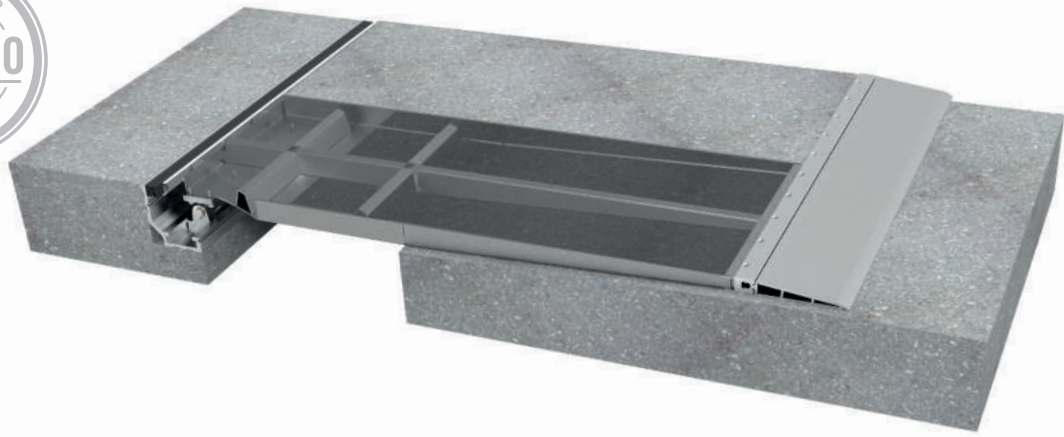

» AR961-500

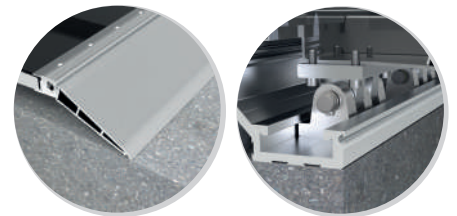
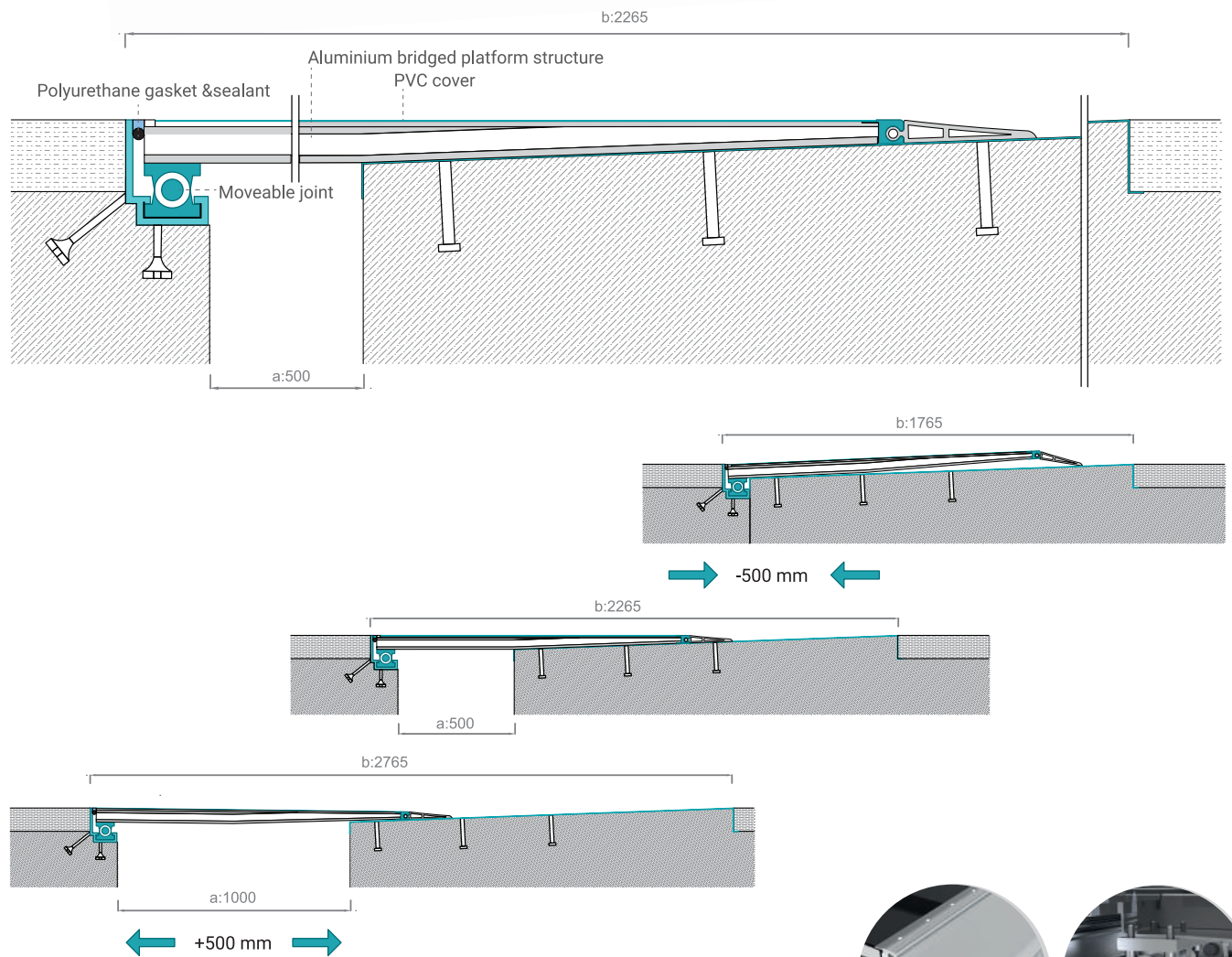

Jointed Expansion Joint profiles are designed for large gaps with high movement capacity. Can often be seen in seismic isolated buildings. Suitable for vehicles, ramps and carparks.

PRODUCT CODE	DESCRIPTION	JOINT WIDTH (a) mm	VISIBLE SURFACE (b) mm	PROFILE HEIGHT (h) mm	TOTAL WIDTH (s) mm	SURFACE	MOVEMENT CAPACITY mm	LOAD CAPACITY
AR961-400	High moving capacity for large gaps	400	2065	65	2065	Alu.+Galvanized Steel+PVC	± 400	9 Ton
AR961-500	High moving capacity for large gaps	500	2265	65	2265	Alu.+Galvanized Steel+PVC	± 500	9 Ton
AR961-600	High moving capacity for large gaps	600	2465	65	2465	Alu.+Galvanized Steel+PVC	± 600	9 Ton
AR961-700	High moving capacity for large gaps	700	2665	65	2665	Alu.+Galvanized Steel+PVC	± 700	9 Ton
AR971-400	High moving capacity for large gaps	400	1274	65	1274	Alu.+Galvanized Steel+PVC	± 300	Pedestrian Stretcher Traffic
AR971-500	High moving capacity for large gaps	500	1474	65	1474	Alu.+Galvanized Steel+PVC	± 300	Pedestrian Stretcher Traffic
AR971-600	High moving capacity for large gaps	600	1674	65	1674	Alu.+Galvanized Steel+PVC	± 300	Pedestrian Stretcher Traffic
AR971-700	High moving capacity for large gaps	700	1874	65	1874	Alu.+Galvanized Steel+PVC	± 300	Pedestrian Stretcher Traffic
AR971-750	High moving capacity for large gaps	750	1924	65	1924	Alu.+Galvanized Steel+PVC	± 300	Pedestrian Stretcher Traffic



» AR971-750

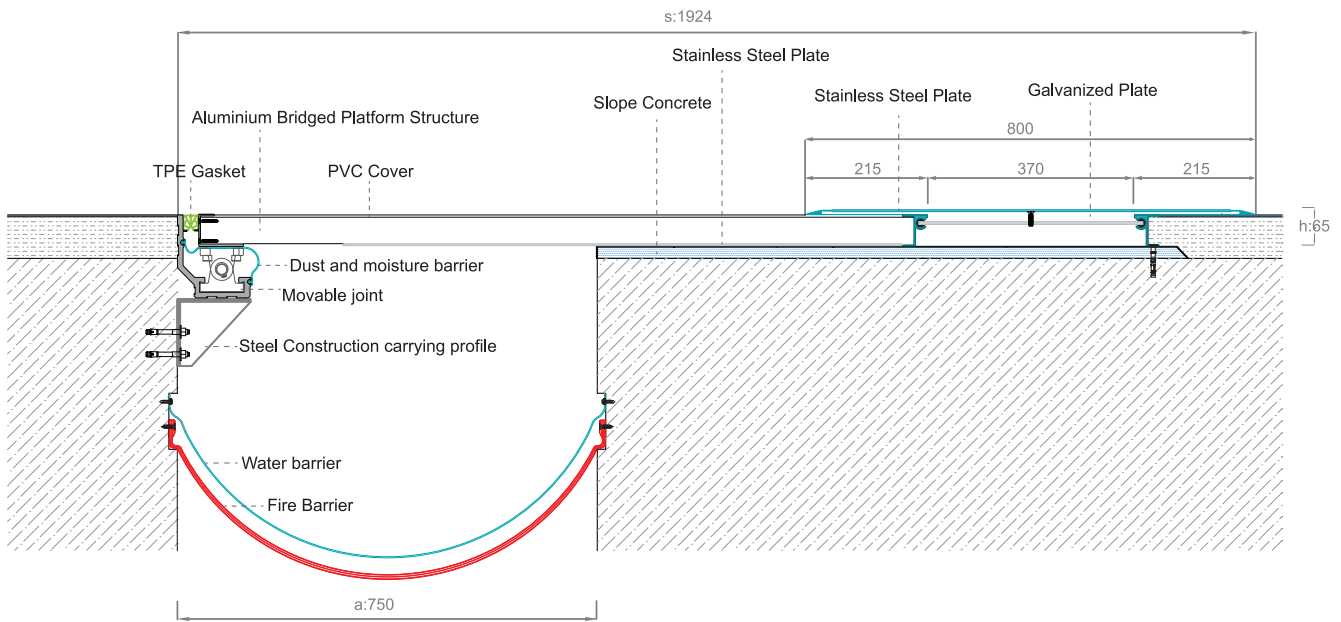

SEISMIC
EXPANSION JOINT
PROFILES

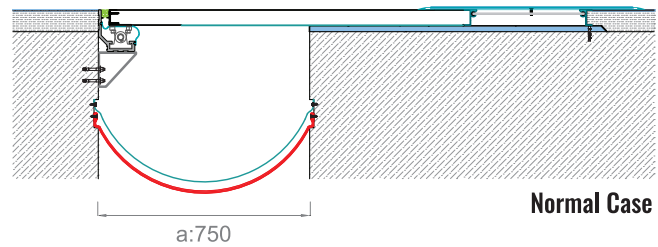
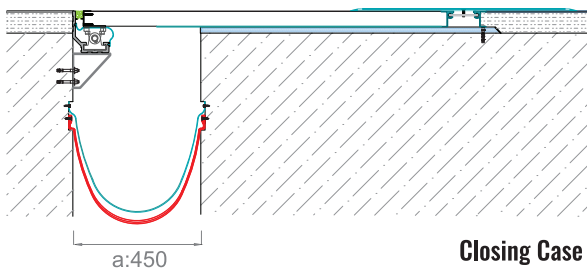

← -300 mm →

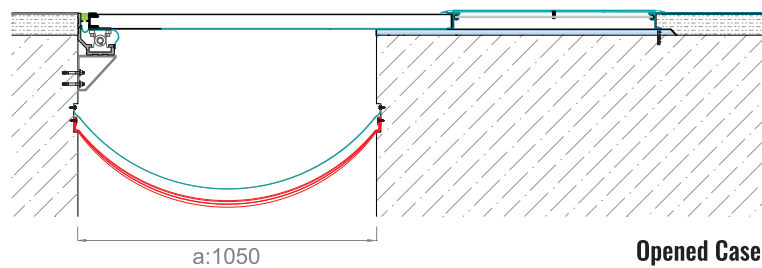

← +300 mm →

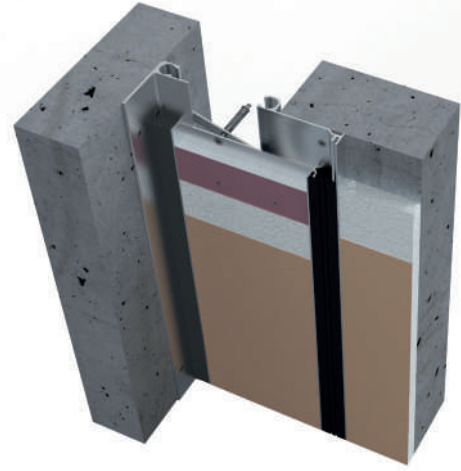
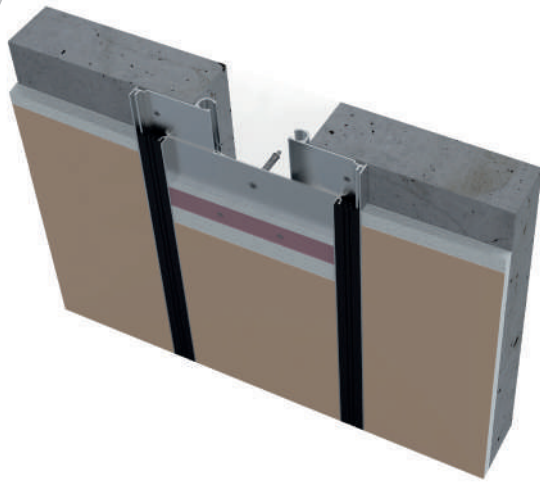

» AR232-100

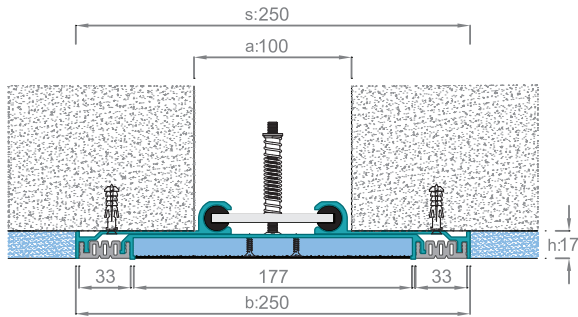

» AR232-150

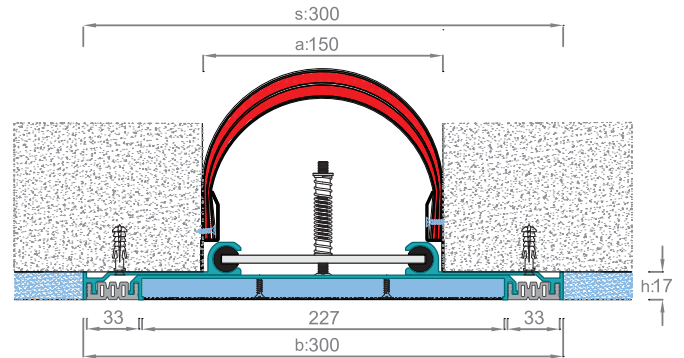

» AR232-150K

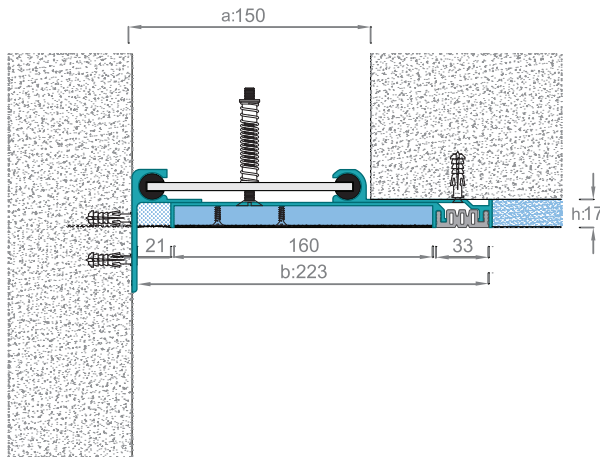

AR 232 series are the wall and ceiling solutions of AR 802 seismic expansion joint series.
(Please refer to page 51 for detailed information.)



PRODUCT CODE	DESCRIPTION	JOINT WIDTH (a) mm	VISIBLE SURFACE (b) mm	PROFILE HEIGHT (h) mm	TOTAL WIDTH (s) mm	SURFACE	MOVEMENT CAPACITY mm
AR 232 - 100	Suitable with screed, drywall and etc./gasketed	100	250	17	250	Mill Finish Alu.+TPE+Cover	± 50
AR 232 - 150	Suitable with screed, drywall and etc./gasketed	150	300	17	300	Mill Finish Alu.+TPE+Cover	± 70
AR 232 - 200	Suitable with screed, drywall and etc./gasketed	200	400	20	400	Mill Finish Alu.+TPE+Cover	+100/-80
AR 232 - 250	Suitable with screed, drywall and etc./gasketed	250	480	20	480	Mill Finish Alu.+TPE+Cover	+125/-80
AR 232 - 300	Suitable with screed, drywall and etc./gasketed	300	600	20	600	Mill Finish Alu.+TPE+Cover	± 150
AR 232 - 350	Suitable with screed, drywall and etc./gasketed	350	650	20	650	Mill Finish Alu.+TPE+Cover	± 175
AR 232 - 400	Suitable with screed, drywall and etc./gasketed	400	700	20	700	Mill Finish Alu.+TPE+Cover	+175/-200
AR 232 - 450	Suitable with screed, drywall and etc./gasketed	450	750	20	750	Mill Finish Alu.+TPE+Cover	+175/-225
AR 232 - 500	Suitable with screed, drywall and etc./gasketed	500	800	20	800	Mill Finish Alu.+TPE+Cover	+175/-250

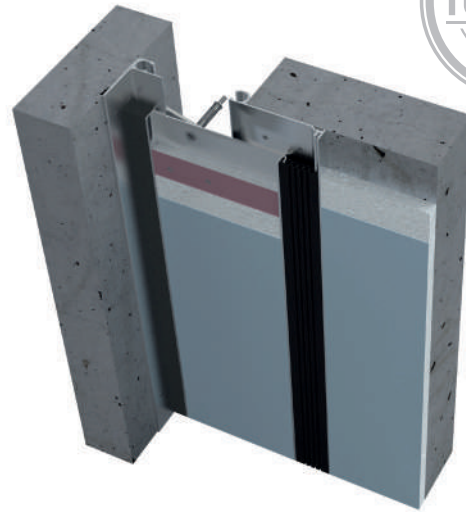
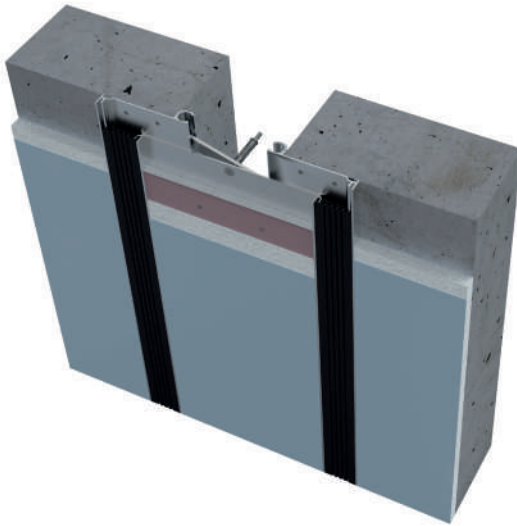

» AR233-100

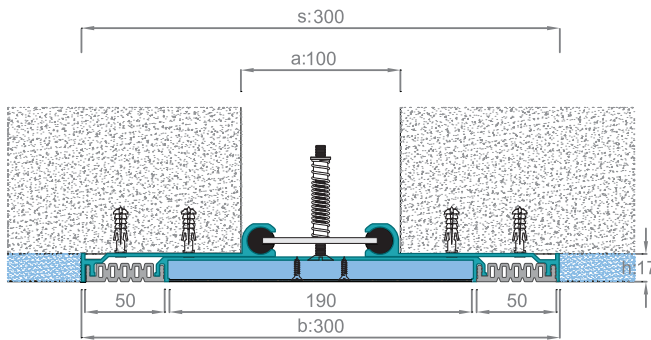

» AR233-150

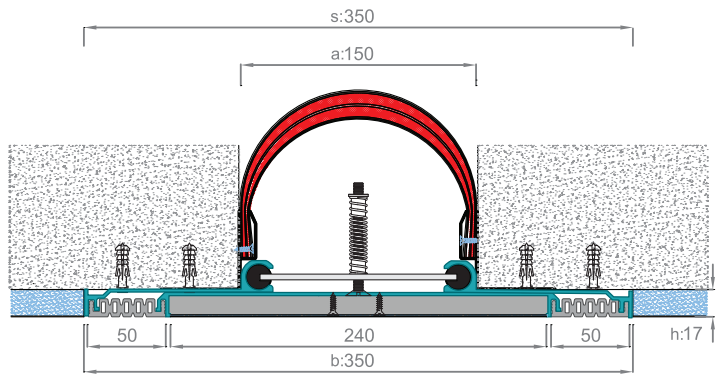

SEISMIC
EXPANSION JOINT
PROFILES

» AR233-150K

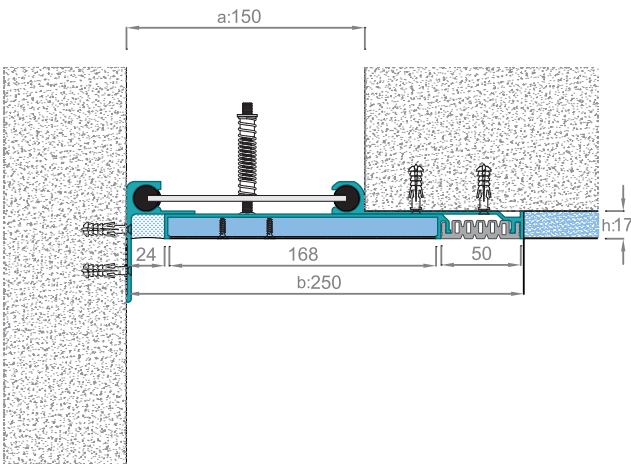

AR 233 wall and ceiling series are applicable to the projects where AR 803 seismic floor profiles have been used. (Please refer to page 52 for detailed information.)



APPLICATIONS

PRODUCT CODE	DESCRIPTION	JOINT WIDTH (a) mm	VISIBLE SURFACE (b) mm	PROFILE HEIGHT (h) mm	TOTAL WIDTH (s) mm	SURFACE	MOVEMENT CAPACITY mm
AR233-100	Suitable with screed, drywall and etc./gasketed	100	300	17	300	Mill Finish Alu.+TPE+Cover	± 50
AR233-150	Suitable with screed, drywall and etc./gasketed	150	350	17	350	Mill Finish Alu.+TPE+Cover	± 75
AR233-200	Suitable with screed, drywall and etc./gasketed	200	400	20	400	Mill Finish Alu.+TPE+Cover	±100

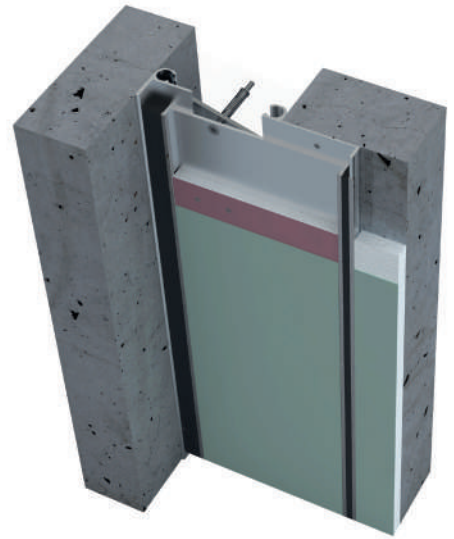
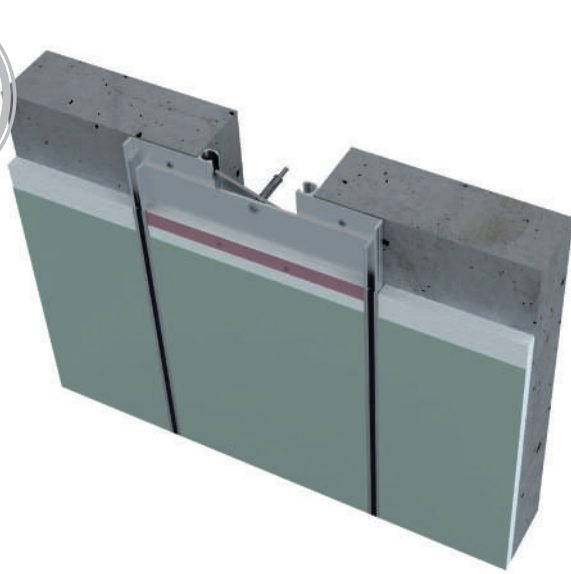

» AR234-100

» AR234-150

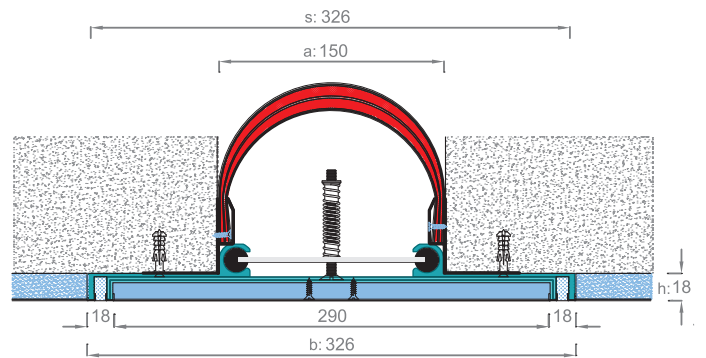
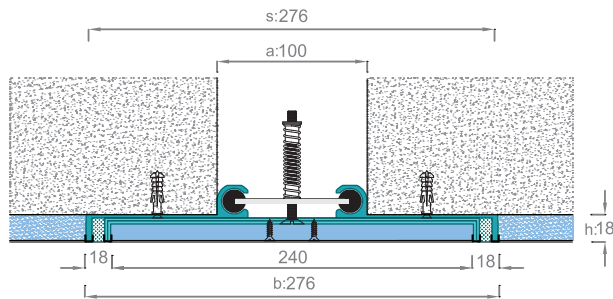

» AR234-150K

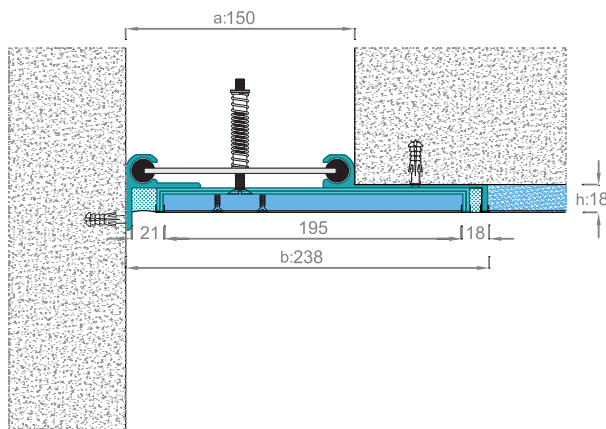

AR 234 seismic series are compatible with AR 804 series floor expansion joint profiles. (Please refer to page 53 for detailed information.)

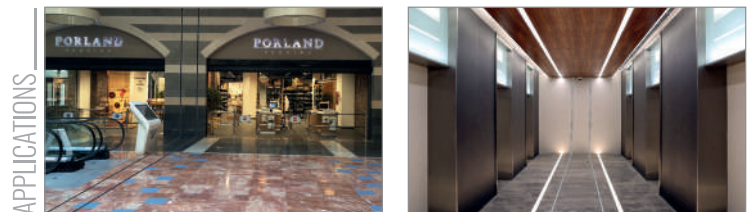

PRODUCT CODE	DESCRIPTION	JOINT WIDTH (a) mm	VISIBLE SURFACE (b) mm	PROFILE HEIGHT (h) mm	TOTAL WIDTH (s) mm	SURFACE	MOVEMENT CAPACITY mm
AR234-100	Suitable with ceramic, drywall and etc./Stainless Steel Surface	100	276	18	276	Stainless Steel+Sealant+Cover	± 50
AR234-150	Suitable with ceramic, drywall and etc./Stainless Steel Surface	150	326	18	326	Stainless Steel+Sealant+Cover	± 75
AR234-200	Suitable with ceramic, drywall and etc./Stainless Steel Surface	200	490	18	490	Stainless Steel+Sealant+Cover	± 75
AR234-250	Suitable with ceramic, drywall and etc./Stainless Steel Surface	250	540	18	540	Stainless Steel+Sealant+Cover	± 75
AR234-300	Suitable with ceramic, drywall and etc./Stainless Steel Surface	300	590	18	590	Stainless Steel+Sealant+Cover	± 75

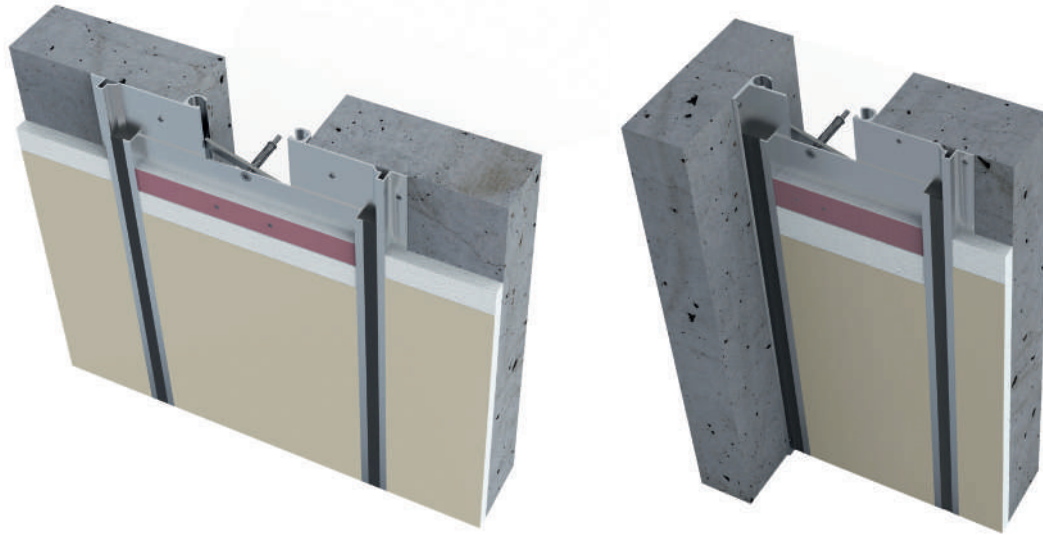

» AR236-100

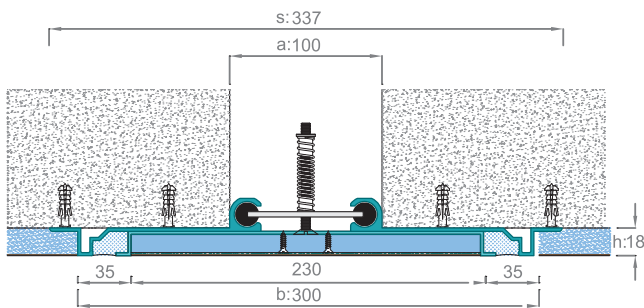

» AR236-150

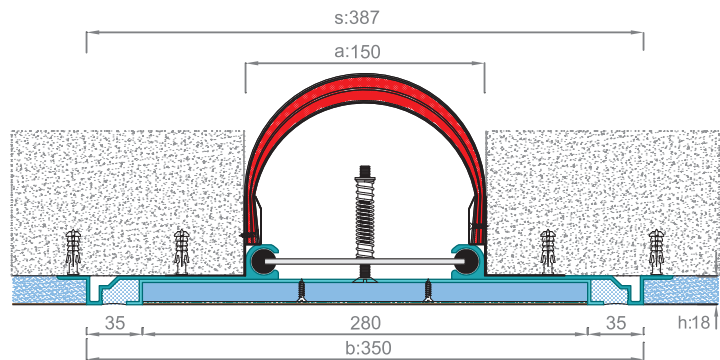

SEISMIC EXPANSION JOINT PROFILES

» AR236-150K

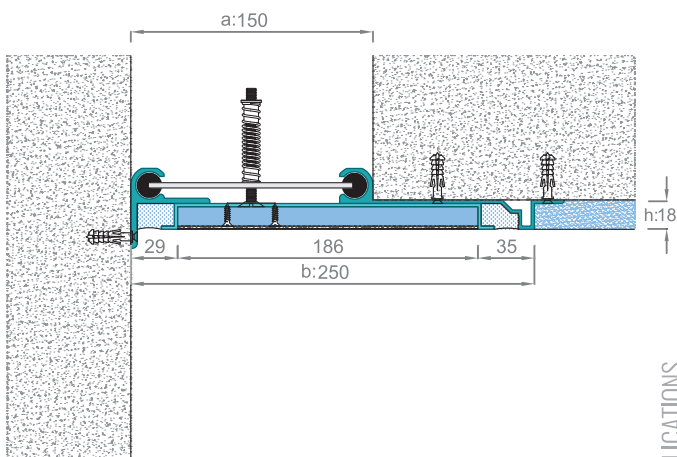

AR 236 wall and ceiling series are suitable to places where AR 806 seismic floor expansion joint profiles have been used. (Please refer to page 54 for detailed information.)

APPLICATIONS



PRODUCT CODE	DESCRIPTION	JOINT WIDTH (a) mm	VISIBLE SURFACE (b) mm	PROFILE HEIGHT (h) mm	TOTAL WIDTH (s) mm	SURFACE	MOVEMENT CAPACITY mm
AR236-100	Suitable with screed, ceramic, drywall, and etc. / Sealant Application	100	300	18	337	Mill Finish Alu.+ Sealant+ Cover	± 50
AR236-150	Suitable with screed, ceramic, drywall, and etc. / Sealant Application	150	350	18	387	Mill Finish Alu.+ Sealant+ Cover	± 75
AR236-200	Suitable with screed, ceramic, drywall, and etc. / Sealant Application	200	400	18	437	Mill Finish Alu.+ Sealant+ Cover	±100
AR236-250	Suitable with screed, ceramic, drywall, and etc. / Sealant Application	250	550	18	587	Mill Finish Alu.+ Sealant+ Cover	±125
AR236-300	Suitable with screed, ceramic, drywall, and etc. / Sealant Application	300	600	18	637	Mill Finish Alu.+ Sealant+ Cover	± 150
AR236-350	Suitable with screed, ceramic, drywall, and etc. / Sealant Application	350	650	18	687	Mill Finish Alu.+ Sealant+ Cover	± 175
AR236-400	Suitable with screed, ceramic, drywall, and etc. / Sealant Application	400	700	18	737	Mill Finish Alu.+ Sealant+ Cover	±200
AR236-450	Suitable with screed, ceramic, drywall, and etc. / Sealant Application	450	750	18	787	Mill Finish Alu.+ Sealant+ Cover	±200
AR236-500	Suitable with screed, ceramic, drywall, and etc. / Sealant Application	500	800	18	837	Mill Finish Alu.+ Sealant+ Cover	±200

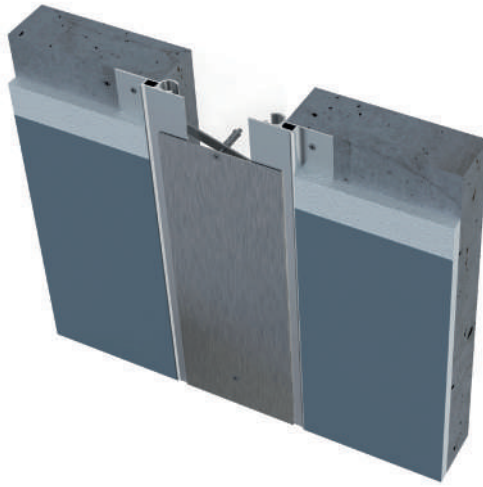

» AR243-100

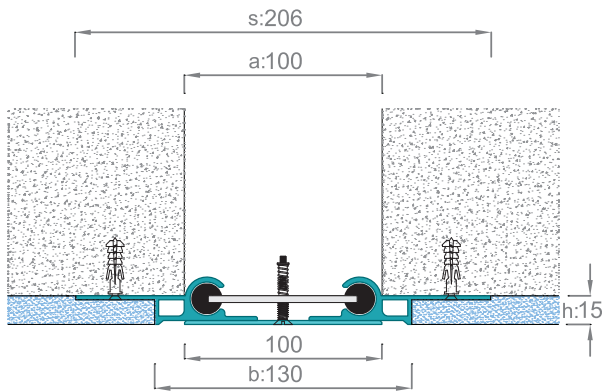

» AR243-150

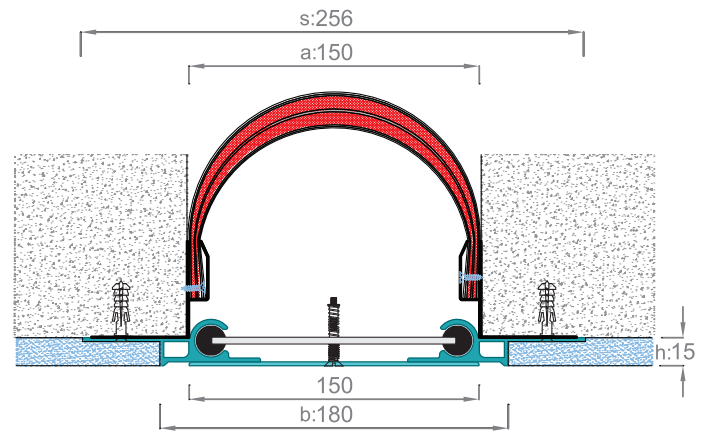

» AR243-150K

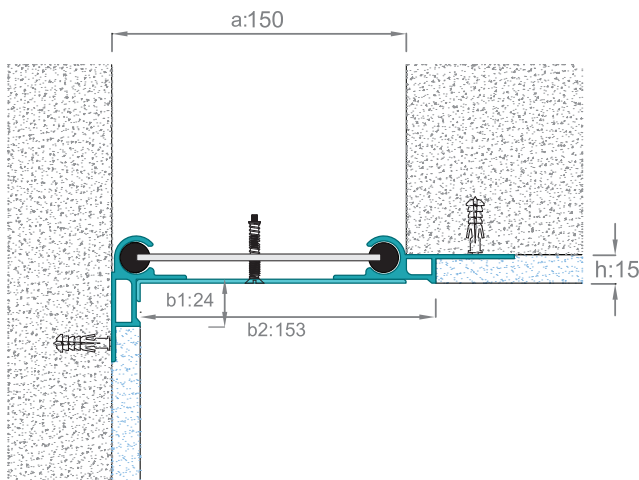

AR 243 series are preferred with its shiny top surface where AR 813 series has been used on the floor. (Please refer to page 55 for detailed information.)



PRODUCT CODE	DESCRIPTION	JOINT WIDTH (a) mm	VISIBLE SURFACE (b) mm	PROFILE HEIGHT (h) mm	TOTAL WIDTH (s) mm	SURFACE	MOVEMENT CAPACITY mm
AR243-100	Suitable with screed, ceramic, drywall, and etc. / Stainless Steel top surface	100	130	15	206	Mill Finish Alu.+Stainles Steel	+40/-50
AR243-150	Suitable with screed, ceramic, drywall, and etc. / Stainless Steel top surface	150	180	15	256	Mill Finish Alu.+Stainles Steel	+60/-75
AR243-200	Suitable with screed, ceramic, drywall, and etc. / Stainless Steel top surface	200	230	15	306	Mill Finish Alu.+Stainles Steel	+60/-100
AR243-250	Suitable with screed, ceramic, drywall, and etc. / Stainless Steel top surface	250	280	15	356	Mill Finish Alu.+Stainles Steel	+60/-125
AR243-300	Suitable with screed, ceramic, drywall, and etc. / Stainless Steel top surface	300	330	15	406	Mill Finish Alu.+Stainles Steel	+60/-150

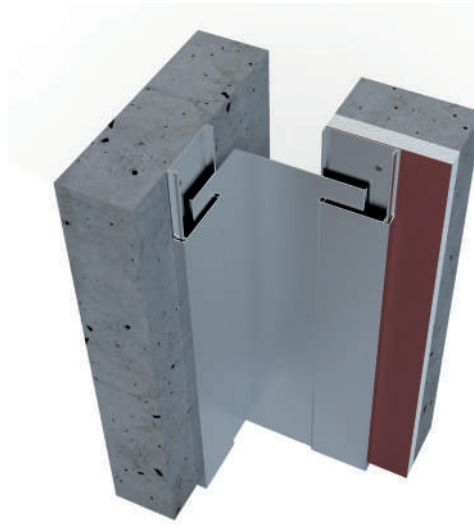

» AR281-050

» AR281-050 - DOUBLE LAYERED DRYWALL APPLICATION ALTERNATIVE

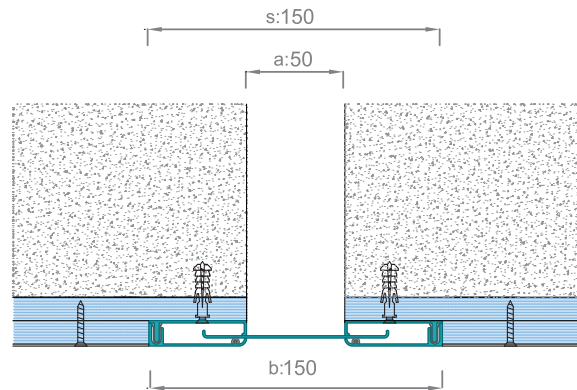
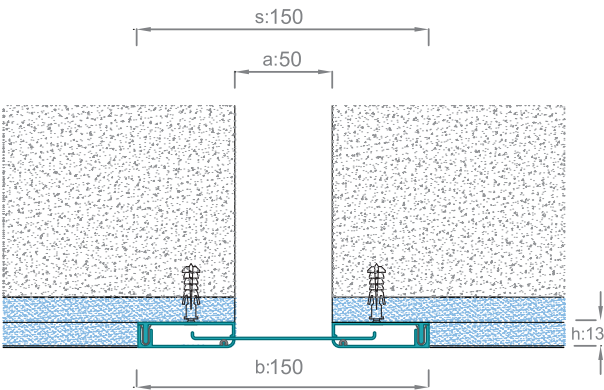

SEISMIC
EXPANSION JOINT
PROFILES

» AR281-100

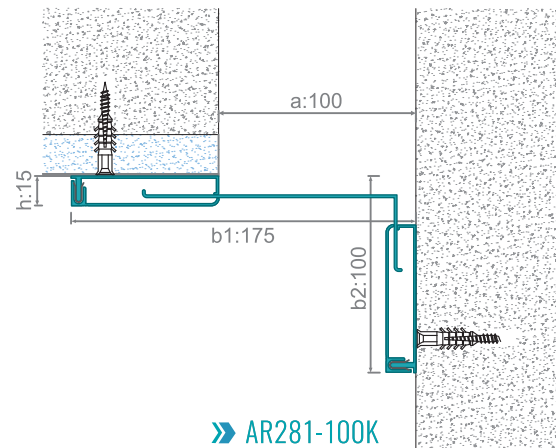
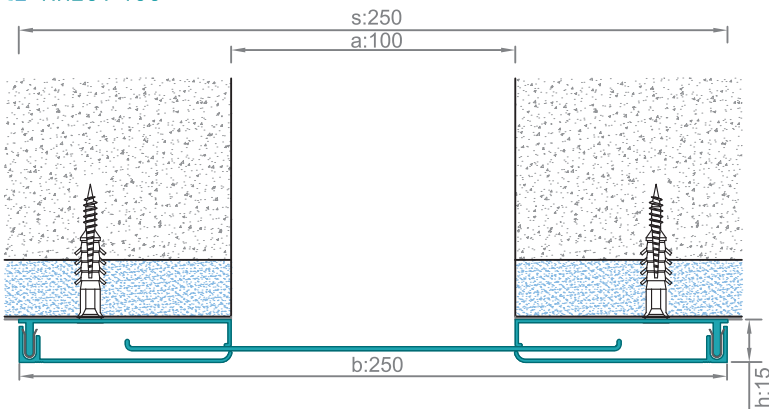

» AR281-100K

Wall and Ceiling profiles are suitable for all kinds of wall coverings with the special Aluminium top surface. Can be delivered by anodised or powder coated. Adoptable with most types of floor Expansion Joint Profiles

APPLICATIONS



PRODUCT CODE	DESCRIPTION	JOINT WIDTH (a) mm	VISIBLE SURFACE (b) mm	PROFILE HEIGHT (h) mm	TOTAL WIDTH (s) mm	SURFACE	MOVEMENT CAPACITY mm
AR281-050	Aluminium top surface, anodised seismic wall and ceiling profile	50	150	13	150	Anodised Alu.	± 40
AR281-100	Aluminium top surface, anodised seismic wall and ceiling profile	100	250	15	250	Anodised Alu.	± 50
AR281-150	Aluminium top surface, anodised seismic wall and ceiling profile	150	300	15	300	Anodised Alu.	± 65
AR281-200	Aluminium top surface, anodised seismic wall and ceiling profile	200	350	15	350	Anodised Alu.	± 65
AR281-250	Aluminium top surface, anodised seismic wall and ceiling profile	250	400	15	400	Anodised Alu.	± 65
AR281-300	Aluminium top surface, anodised seismic wall and ceiling profile	300	450	15	450	Anodised Alu.	± 65

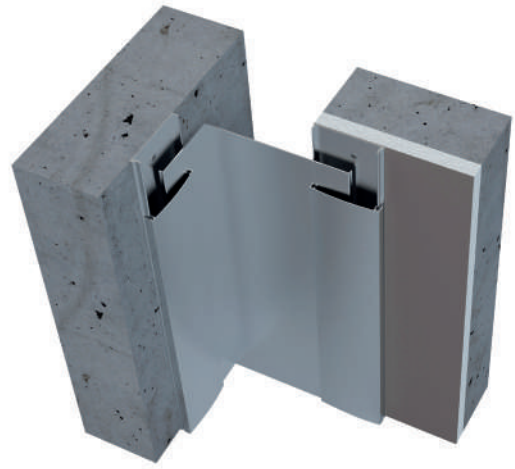

» AR291-100

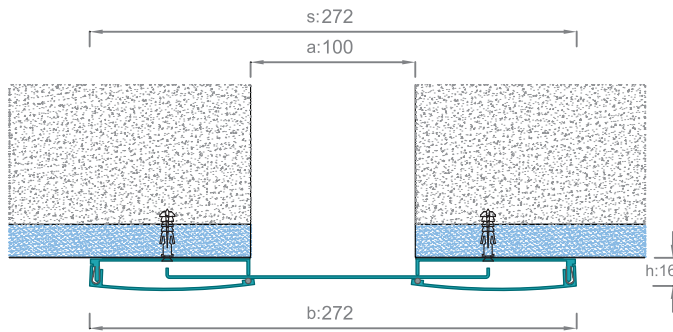

» AR291-100K

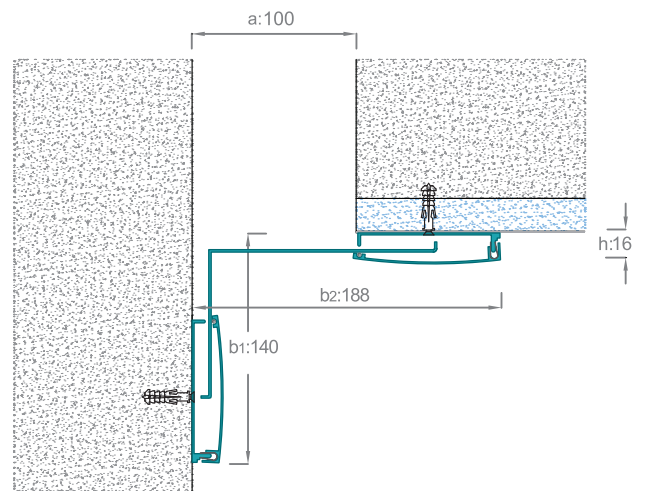

» AR291-150

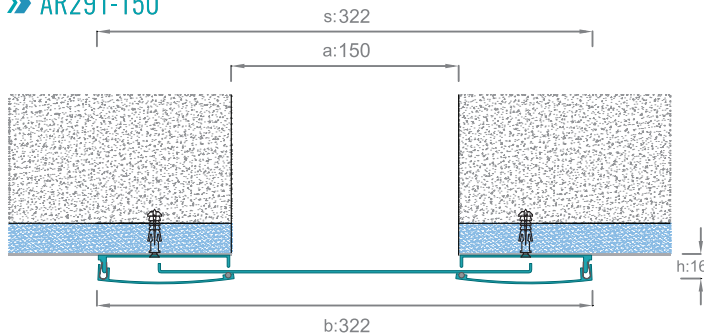

» AR291-150K

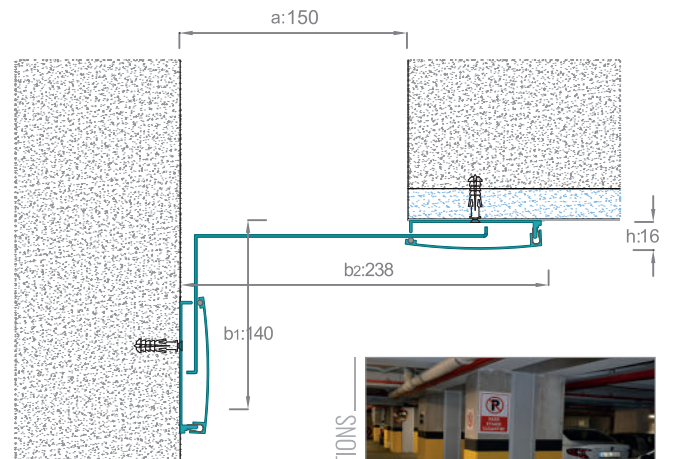

Seismic wall and ceiling profiles have the wide and decorative side surface. Can be delivered by powder coated or anodised.

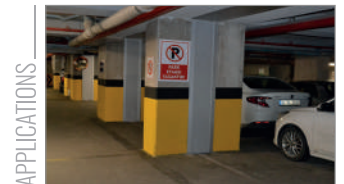

PRODUCT CODE	DESCRIPTION	JOINT WIDTH (a) mm	VISIBLE SURFACE (b) mm	PROFILE HEIGHT (h) mm	TOTAL WIDTH (s) mm	SURFACE	MOVEMENT CAPACITY mm
AR291-050	Aluminium top surface, anodised seismic wall and ceiling profile	50	222	16	222	Anodised Alu.	± 50
AR291-100	Aluminium top surface, anodised seismic wall and ceiling profile	100	272	16	272	Anodised Alu.	± 75
AR291-150	Aluminium top surface, anodised seismic wall and ceiling profile	150	322	16	322	Anodised Alu.	± 75
AR291-200	Aluminium top surface, anodised seismic wall and ceiling profile	200	372	16	372	Anodised Alu.	± 75
AR291-250	Aluminium top surface, anodised seismic wall and ceiling profile	250	422	16	422	Anodised Alu.	± 75
AR291-300	Aluminium top surface, anodised seismic wall and ceiling profile	300	472	16	472	Anodised Alu.	± 75
AR291-350	Aluminium top surface, anodised seismic wall and ceiling profile	350	522	16	522	Anodised Alu.	± 75
AR291-400	Aluminium top surface, anodised seismic wall and ceiling profile	400	572	16	572	Anodised Alu.	± 75

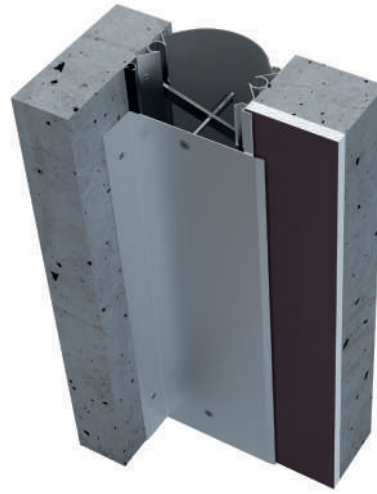
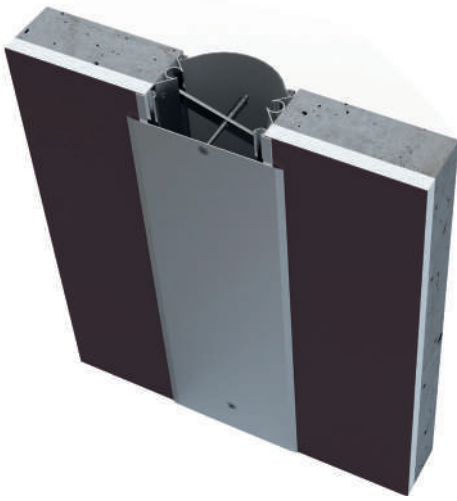

» AR286-100

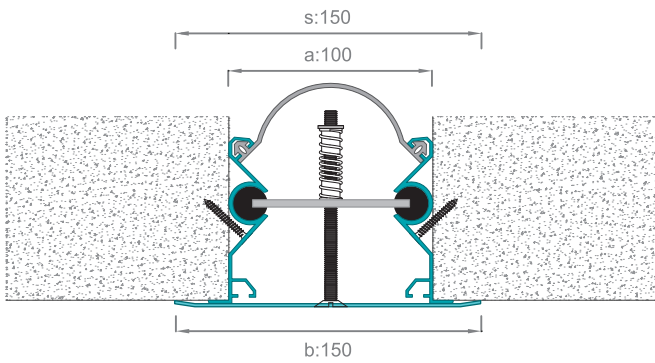

» AR286-100K

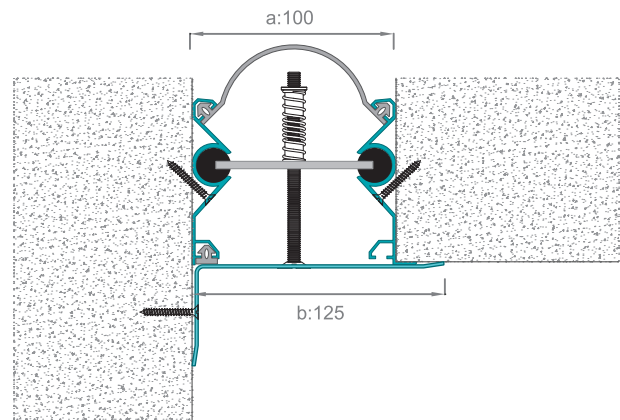

» AR286-150

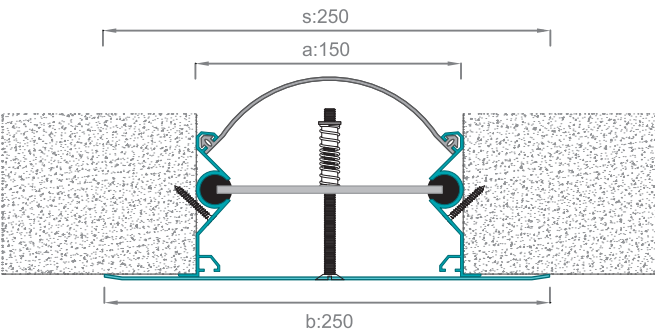

» AR286-150K

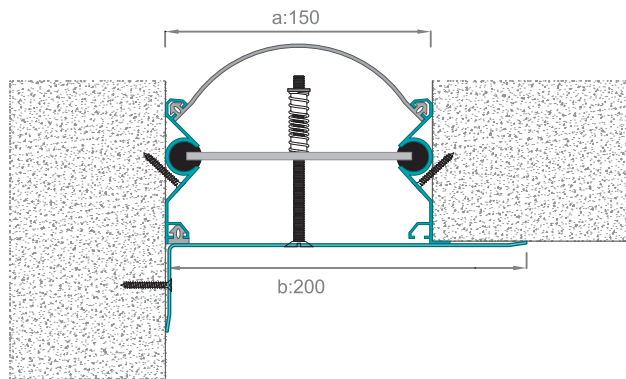

SEISMIC
EXPANSION JOINT
PROFILES

AR 286 Wall and ceiling expansion joint profiles have vapour barriers and movement capacity in 3 dimensional direction. (with screw mounted in the middle). Especially suitable for facade.

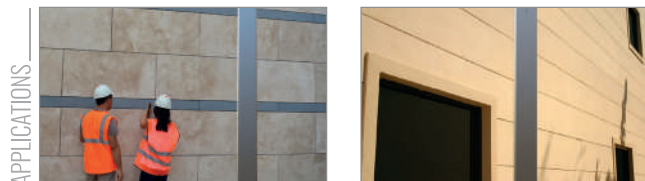

PRODUCT CODE	DESCRIPTION	JOINT WIDTH (a) mm	VISIBLE SURFACE (b) mm	TOTAL WIDTH (s) mm	SURFACE	MOVEMENT CAPACITY mm
AR286-100	Anodised, aluminium top surface seismic wall and ceiling profile	100	150	150	Anodised Alu.	± 50
AR286-150	Anodised, aluminium top surface seismic wall and ceiling profile	150	250	250	Anodised Alu.	± 75
AR286-200	Anodised, aluminium top surface seismic wall and ceiling profile	200	350	350	Anodised Alu.	± 100
AR286-250	Anodised, aluminium top surface seismic wall and ceiling profile	250	400	400	Anodised Alu.	± 125
AR286-300	Anodised, aluminium top surface seismic wall and ceiling profile	300	500	500	Anodised Alu.	± 150



» AR293-150

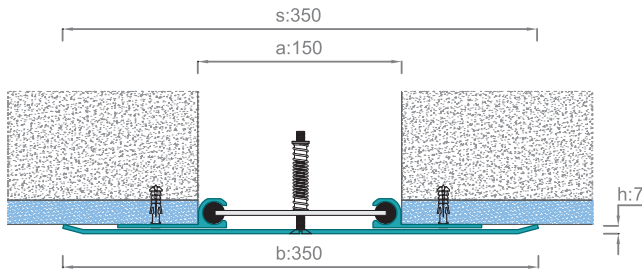

» AR293-150K

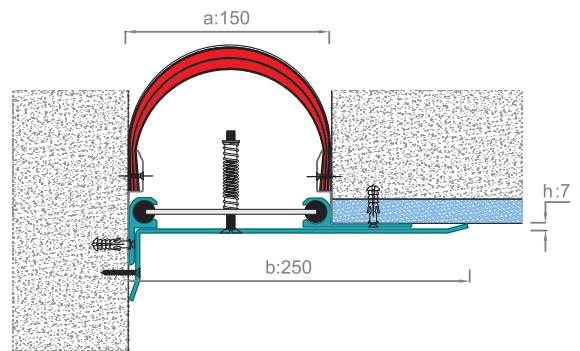

» AR293-200

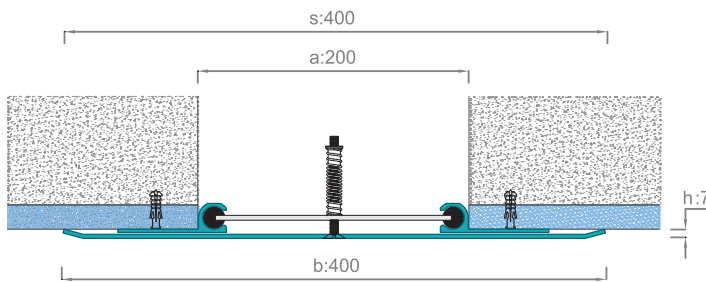

» AR293-200K

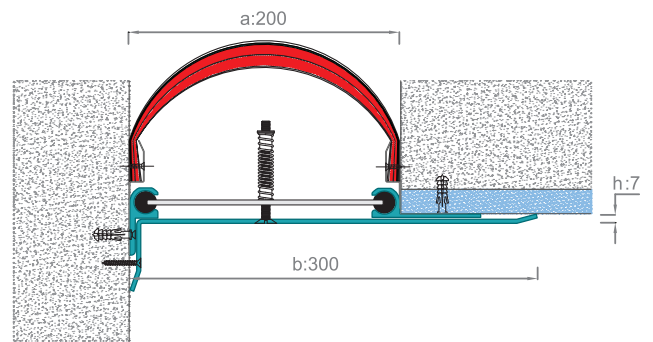

Cover Expansion joint profiles are suitable for carpark walls and ceilings & walls where large movement capacity is being required. Can be produced by anodised or powder coated in required colour.

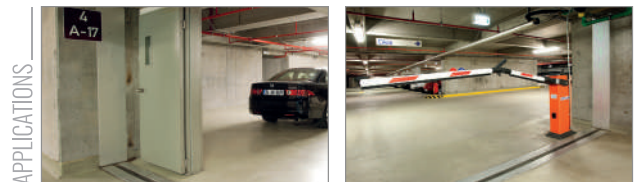

PRODUCT CODE	DESCRIPTION	JOINT WIDTH (a) mm	VISIBLE SURFACE (b) mm	PROFILE HEIGHT (h) mm	TOTAL WIDTH (s) mm	SURFACE	MOVEMENT CAPACITY mm
AR293-100	Anodised, wide aluminium top surface, seismic wall-ceiling profile	100	300	7	300	Anodised Alu.	± 50
AR293-150	Anodised, wide aluminium top surface, seismic wall-ceiling profile	150	350	7	350	Anodised Alu.	± 75
AR293-200	Anodised, wide aluminium top surface, seismic wall-ceiling profile	200	400	7	400	Anodised Alu.	± 100
AR293-250	Anodised, wide aluminium top surface, seismic wall-ceiling profile	250	500	7	500	Anodised Alu.	± 125
AR293-300	Anodised, wide aluminium top surface, seismic wall-ceiling profile	300	600	7	600	Anodised Alu.	± 150

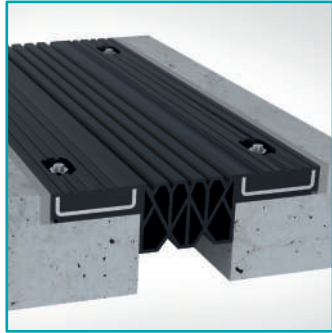
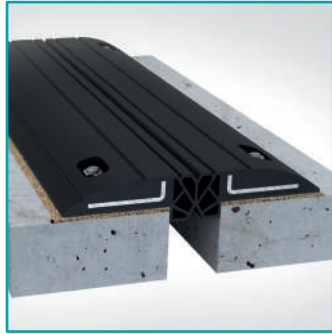
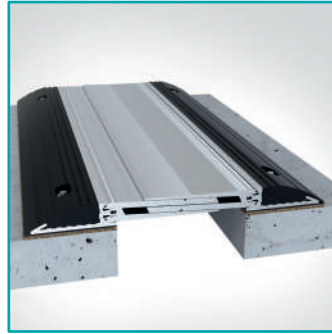
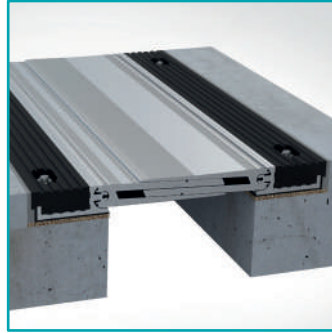

carpark expansion joint profiles

CARPARK
EXPANSION JOINT
PROFILES

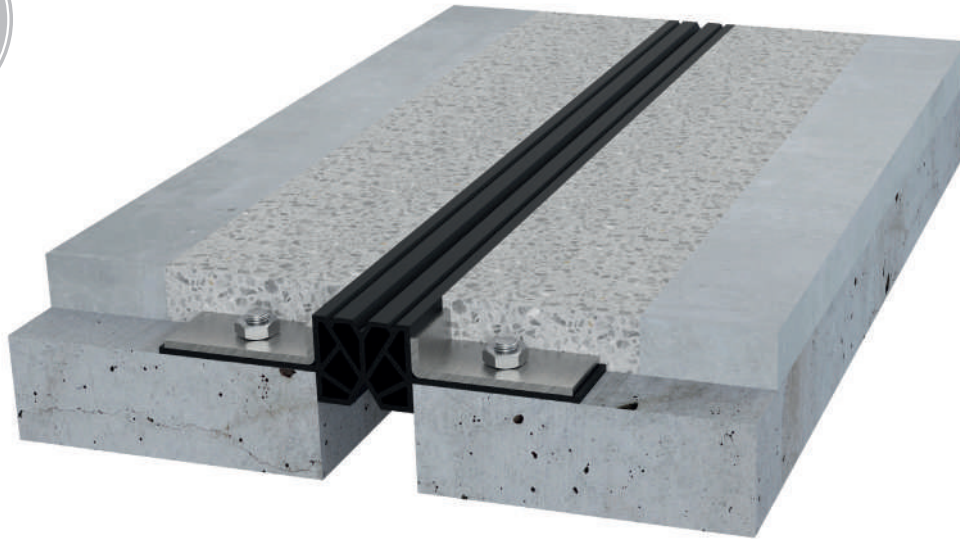

» AR910-050

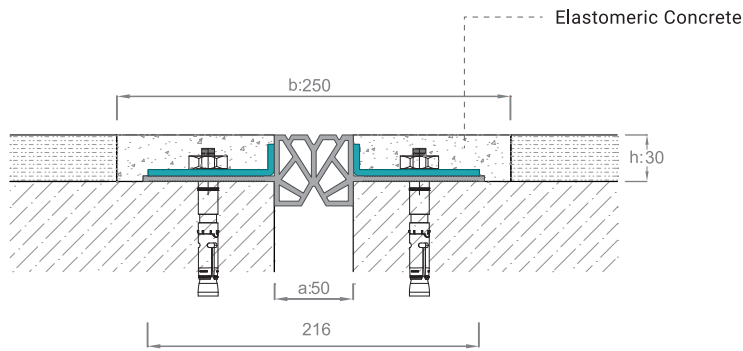

» AR910-050K (CORNER DETAIL)

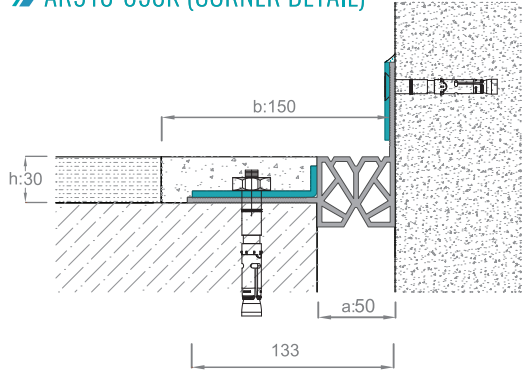

» AR910-100

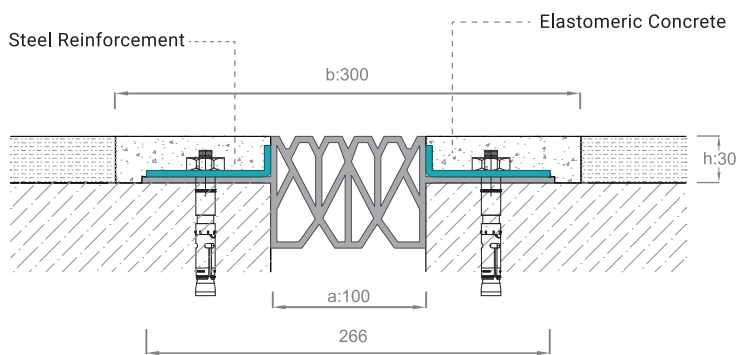

» AR910-100K (CORNER DETAIL)

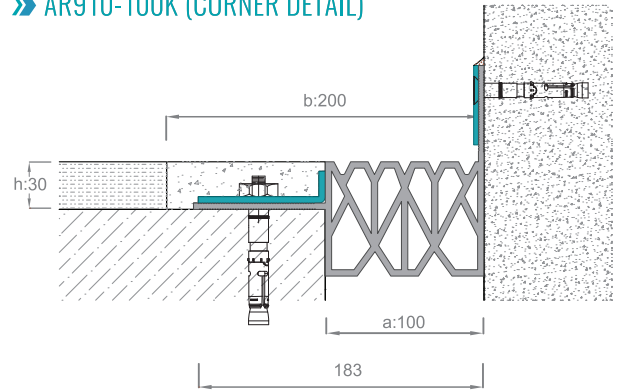

TPE and TPV based Carpark Expansion Joint Profiles are able to settle to the ground only in an hour time. Having such characteristics as high capacity to bend&shrink and resistant to corrosion make AR 910 series suitable to apply on highly polymeric based concrete.

APPLICATIONS



PRODUCT CODE	DESCRIPTION	JOINT WIDTH (a) mm	VISIBLE SURFACE (b) mm	PROFILE HEIGHT (h) mm	TOTAL WIDTH (s) mm	SURFACE	MOVEMENT CAPACITY mm	LOAD CAPACITY
AR 910 - 050	Assembled with steel profiles	50	250	30	216	TPE+Steel	± 25	30 Ton
AR 910 - 100	Assembled with steel profiles	100	300	30	266	TPE+Steel	± 50	30 Ton



» AR911-050

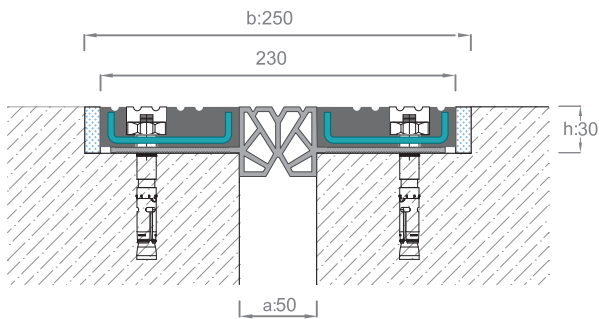

» AR911-050K (CORNER DETAIL)

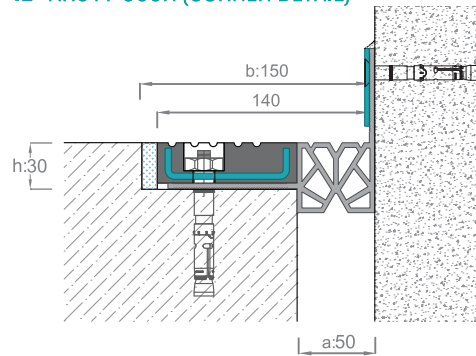

» AR911-100

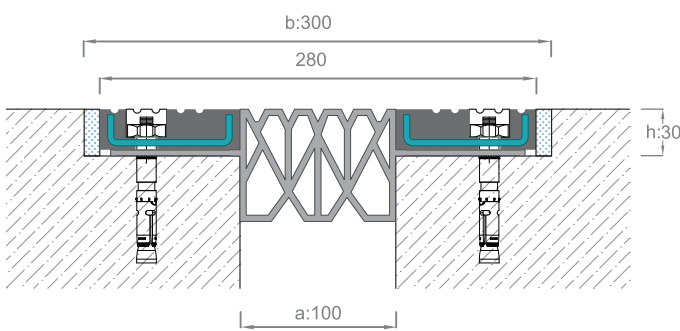

» AR911-100K (CORNER DETAIL)

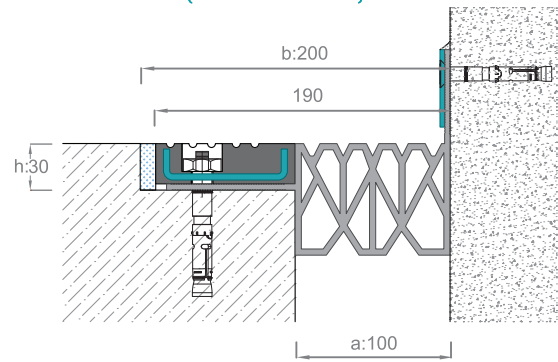

CARPARK
EXPANSION JOINT
PROFILES

TPV and TPE middle parts are resistant to heavy loads, comfortable, quite and waterproofing when mounted properly. Furthermore, Volcanized side profiles are reinforced with steel plates.

APPLICATIONS



PRODUCT CODE	DESCRIPTION	JOINT WIDTH (a) mm	VISIBLE SURFACE (b) mm	PROFILE HEIGHT (h) mm	TOTAL WIDTH (s) mm	SURFACE	MOVEMENT CAPACITY mm	LOAD CAPACITY
AR 911 - 050	Steel reinforced composite floor profile	50	250	30	250	Rubber + TPE	± 25	30 Ton
AR 911 - 051	Steel reinforced composite floor profile	50	250	30	250	Rubber + TPE	± 40	30 Ton
AR 911 - 100	Steel reinforced composite floor profile	100	300	30	300	Rubber + TPE	± 50	30 Ton

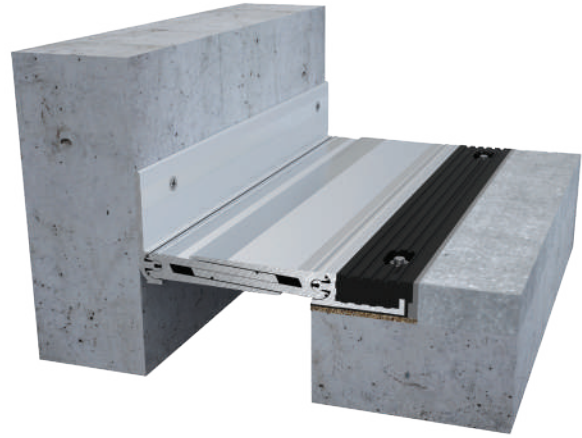
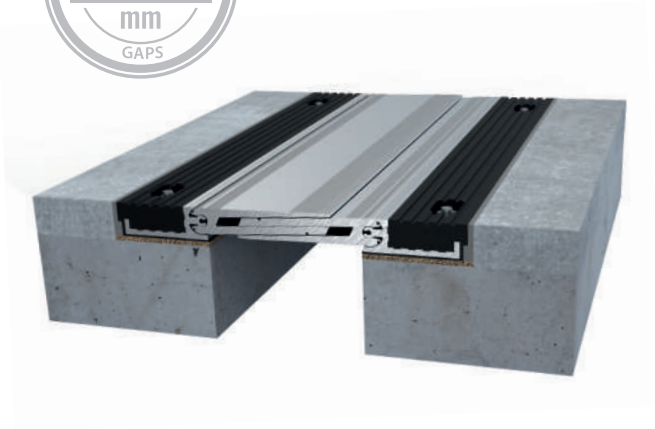

» AR911-150

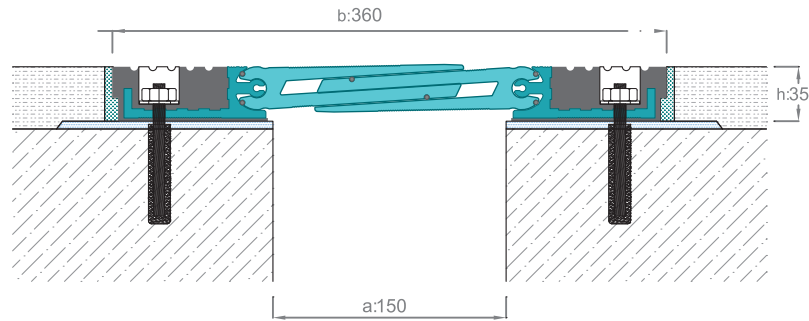

» AR911-200

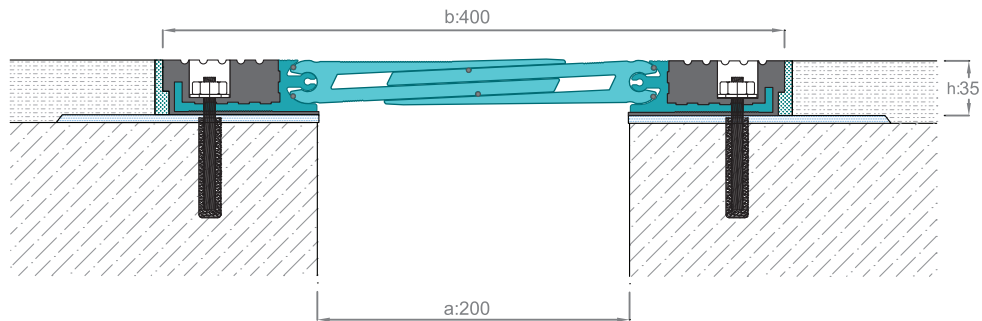

» AR911-150K

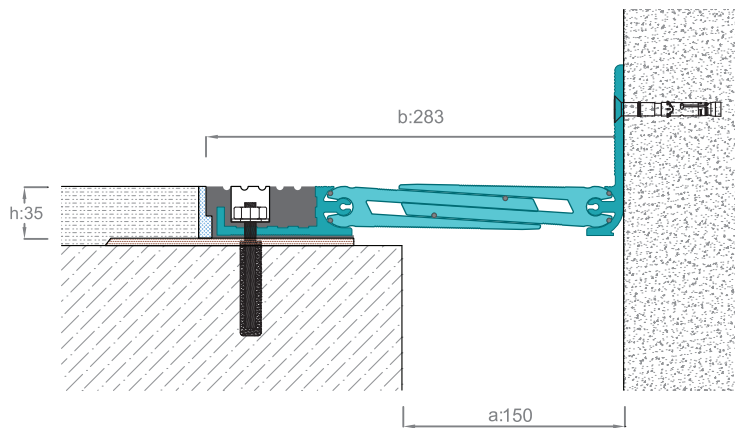

Created for the first time in the WORLD by ARFEN. These rubber + aluminium dilatation profiles successfully applied to wide expansion joint gaps in carparks and industrial structures. Provide opportunity to be quite and comfortable.

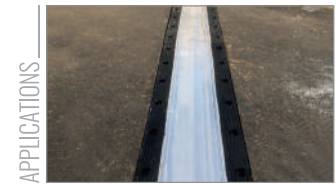

PRODUCT CODE	DESCRIPTION	JOINT WIDTH (a) mm	VISIBLE SURFACE (b) mm	PROFILE HEIGHT (h) mm	TOTAL WIDTH (s) mm	SURFACE	MOVEMENT CAPACITY mm	LOAD CAPACITY
AR 911 - 150	Composite, rubber, aluminium floor profile	150	360	35	360	Mill Finish Alu.+Rubber	+35/-25	30 Ton
AR 911 - 200	Composite, rubber, aluminium floor profile	200	400	35	400	Mill Finish Alu.+Rubber	± 40	16 Ton
AR 911 - 250	Composite, rubber, aluminium floor profile	250	450	35	450	Mill Finish Alu.+Rubber	± 40	9 Ton
AR 911 - 300	Composite, rubber, aluminium floor profile	300	500	35	500	Mill Finish Alu.+Rubber	± 50	6.5 Ton



» AR921-050

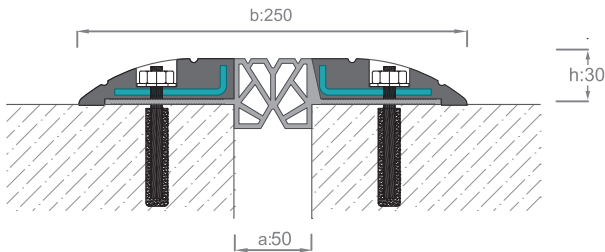

» AR921-051

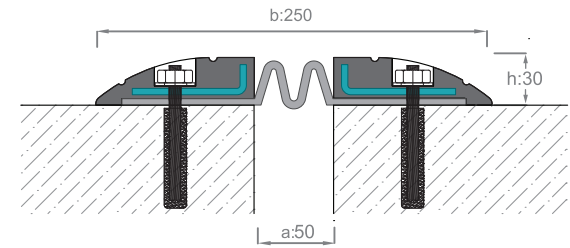

» AR921-100

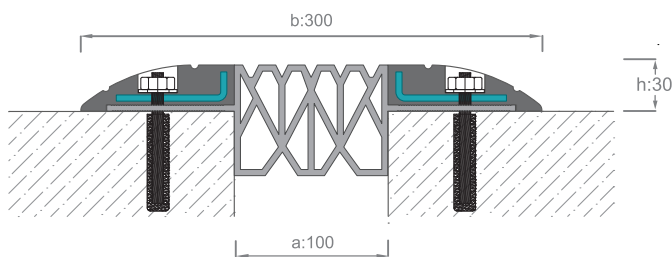

» AR921-100K

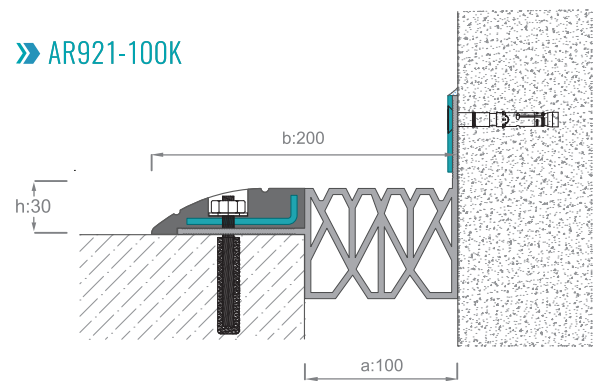

CARPARK
EXPANSION JOINT
PROFILES

AR 921 series are Rubber + Steel composite Expansion Joint Profiles. Applied to floors as over finish profiles and can be used as a speed bumper. As well assembled to the floor by appropriate steel anchors of having 25 cm gaps in between.



APPLICATIONS

PRODUCT CODE	DESCRIPTION	JOINT WIDTH (a) mm	VISIBLE SURFACE (b) mm	PROFILE HEIGHT (h) mm	TOTAL WIDTH (s) mm	SURFACE	MOVEMENT CAPACITY mm	LOAD CAPACITY
AR921-050	Speed bumper, composite, rubber, steel profile	50	250	30	250	Rubber+TPE	± 25	9 Ton
AR921-051	Speed bumper, composite, rubber, steel profile	50	250	30	250	Rubber+TPE	± 40	9 Ton
AR921-100	Speed bumper, composite, rubber, steel profile	100	300	30	300	Rubber+TPE	± 50	9 Ton
AR921-101	Speed bumper, composite, rubber, aluminium	100	300	30	300	Mill Finish Alu.+Rubber	± 20	12 Ton
AR921-150	Speed bumper, composite, rubber, aluminium	150	350	30	350	Mill Finish Alu.+Rubber	± 20	12 Ton
AR921-200	Speed bumper, composite, rubber, aluminium	200	462	35	462	Mill Finish Alu.+Rubber	± 40	9 Ton
AR921-250	Speed bumper, composite, rubber, aluminium	250	512	35	512	Mill Finish Alu.+Rubber	± 50	9 Ton
AR921-300	Speed bumper, composite, rubber, aluminium	300	562	35	562	Mill Finish Alu.+Rubber	± 50	9 Ton

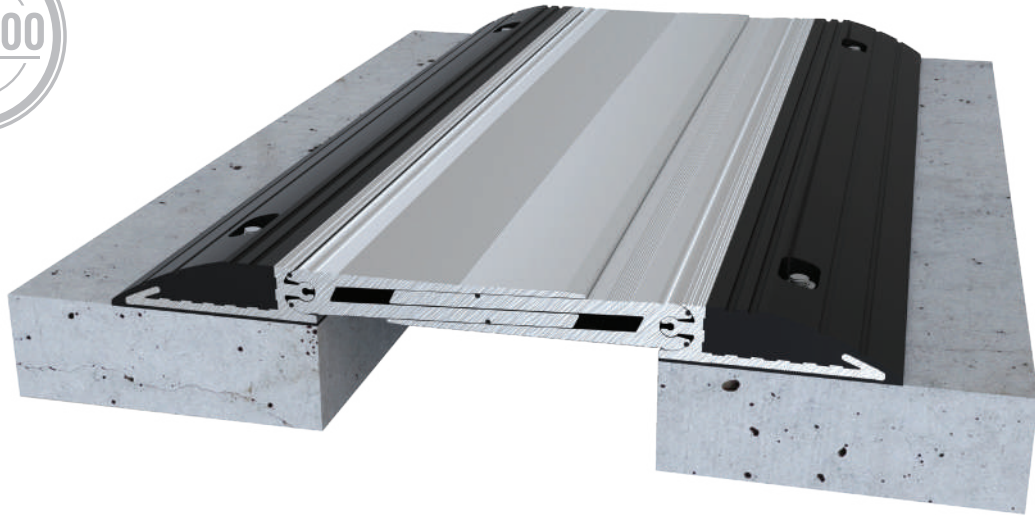

» AR921-101

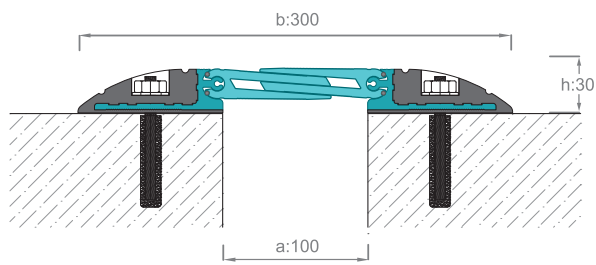

» AR921-150

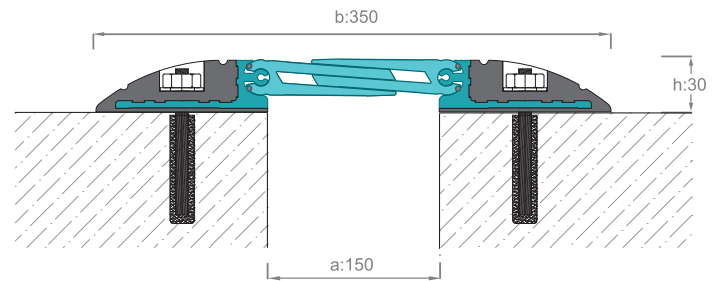

» AR921-200

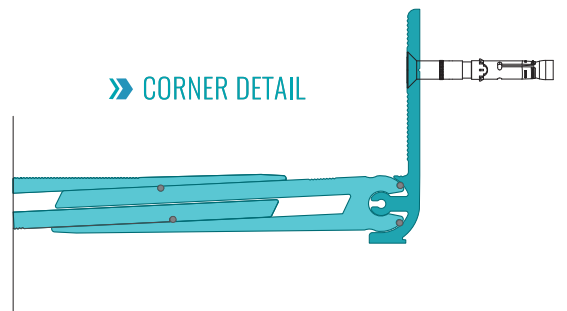
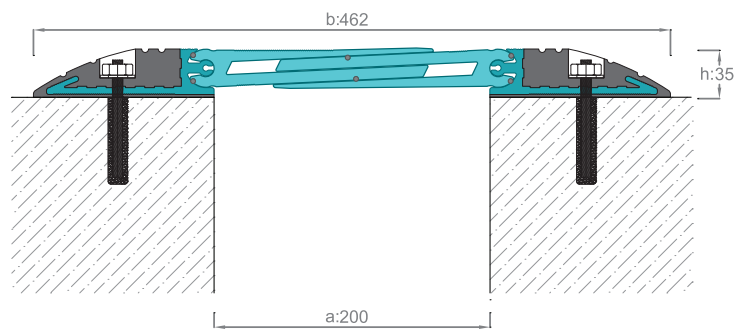

Developed for the first time In the World by ARFEN. Aluminium + TPE rubber Expansion joint profiles also have the corner detail in each design.

APPLICATIONS

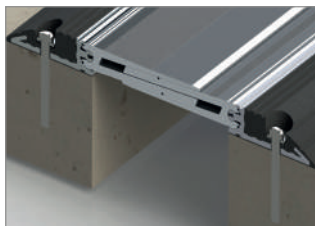



» AR951-050

» AR951-100

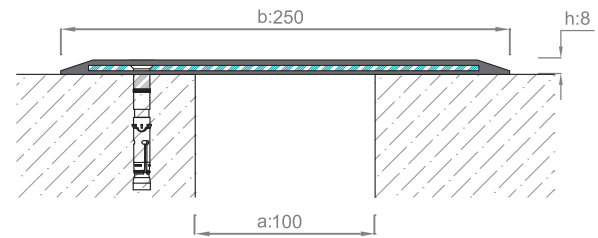
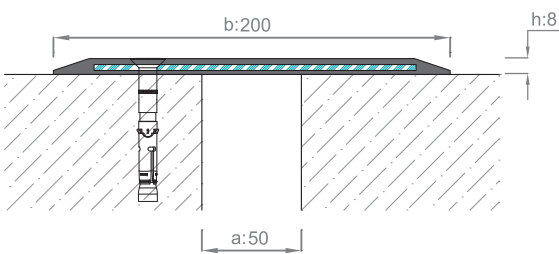

» AR951-150

» AR951-100K

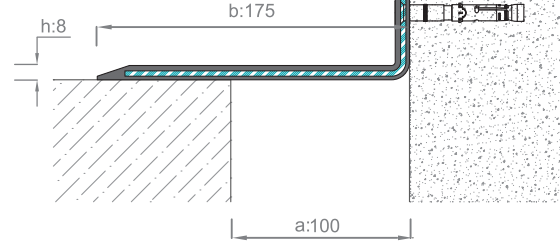
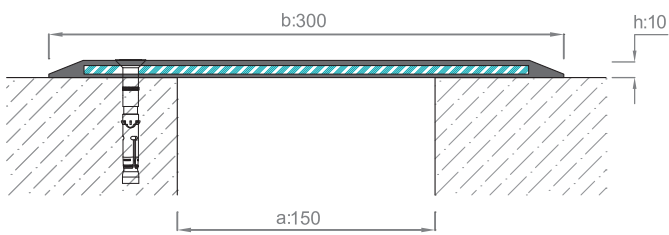

CARPARK
EXPANSION JOINT
PROFILES



APPLICATIONS

AR 951 series are Rubber + Steel composite Expansion Joint Profiles. Applied to floors and can be used as a speed bumper. Assembled to the floor by appropriate steel anchors of having 25 cm intervals.

PRODUCT CODE	DESCRIPTION	JOINT WIDTH (a) mm	VISIBLE SURFACE (b) mm	PROFILE HEIGHT (h) mm	ST 37 STEEL THICKNESS mm	TOTAL WIDTH (s) mm	SURFACE	MOVEMENT CAPACITY mm	LOAD CAPACITY
AR951-050	Composite, Rubber, Steel floor profile	50	200	8	3	200	Rubber	± 50	9 Ton
AR951-100	Composite, Rubber, Steel floor profile	80-100	250	8	3	250	Rubber	+50/-100	9 Ton
AR951-150	Composite, Rubber, Steel floor profile	120-150	300	10	4	300	Rubber	+50/-150	6 Ton
AR951-180	Composite, Rubber, Steel floor profile	180-200	350	12	5	350	Rubber	+65/-180	3.5 Ton
AR951-250	Composite, Rubber, Steel floor profile	250	400	12	6	400	Rubber	+65/-250	3.5 Ton
AR951-300	Composite, Rubber, Steel floor profile	300	600	15	8	600	Rubber	± 28 mm	3.5 Ton



» AR951-300

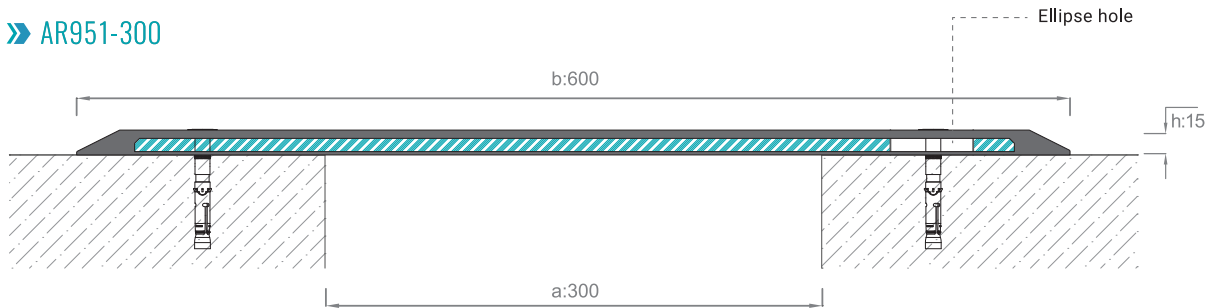

» AR192-050

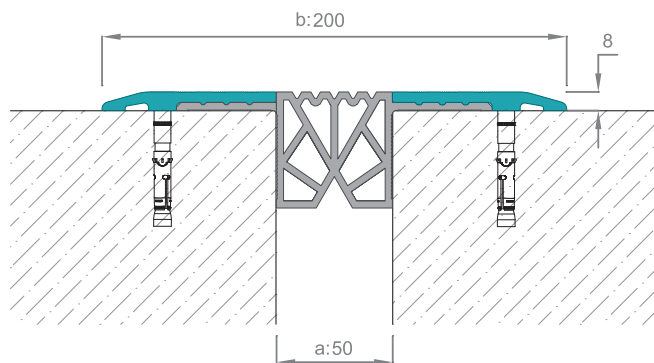

» AR194-050

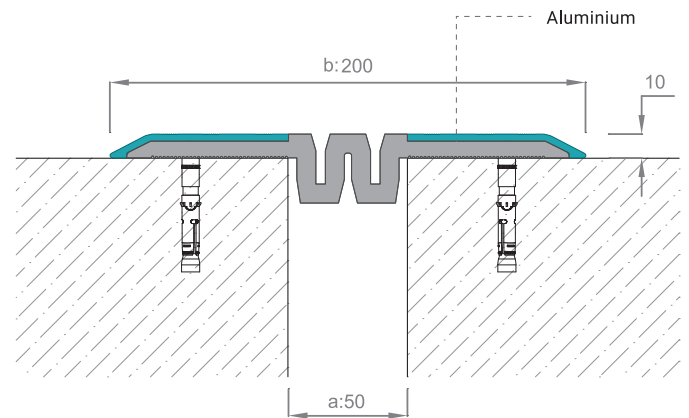

- Stainless Steel top profile can be produced by request.

Aluminium or stainless steel top surfaced expansion joint profiles are suitable for surface mounted floor carpark profiles.

APPLICATIONS



PRODUCT CODE	DESCRIPTION	JOINT WIDTH (a) mm	VISIBLE SURFACE (b) mm	PROFILE HEIGHT (h) mm	TOTAL WIDTH (s) mm	SURFACE	MOVEMENT CAPACITY mm	LOAD CAPACITY
AR 192 - 050	Mill Finish Flush Mounted Floor Profile	50	200	45	200	Mill Finish Alu.+TPE	± 25	9 Ton
AR 193 - 050	Galvanized Flush Mounted Floor Profile	50	170	45	170	Galvanized	± 20	6 Ton
AR 194 - 050	Mill Finish Flush Mounted Floor Profile	50	200	20	200	Mill Finish Alu.+TPE	± 25	9 Ton

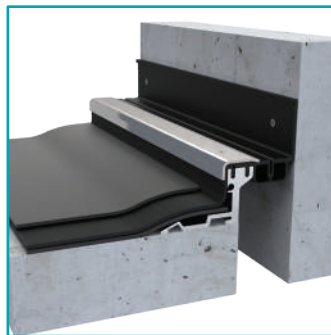
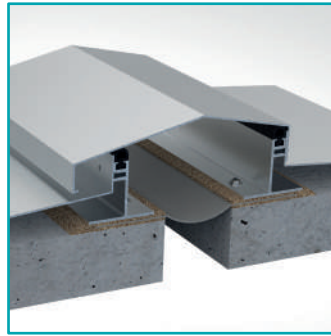
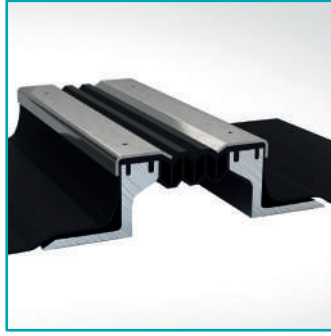
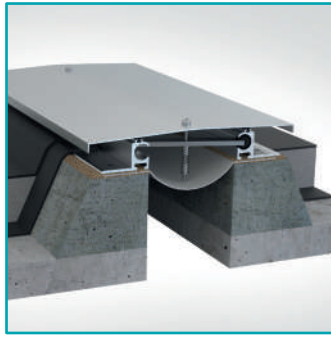

watertight and terrace expansion joint profiles

WATERTIGHT
AND TERRACE
EXPANSION
JOINT PROFILES

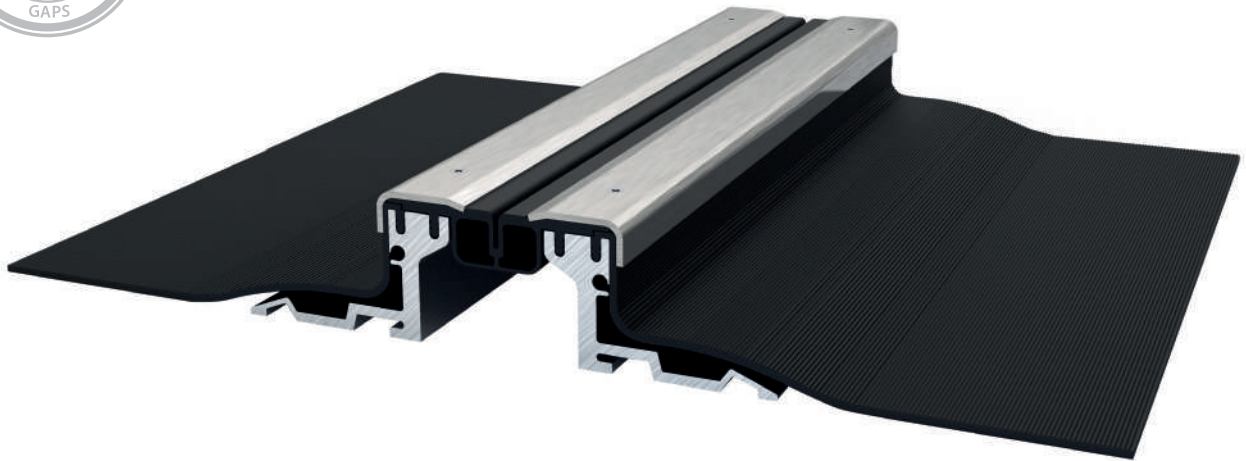

» AR601-050

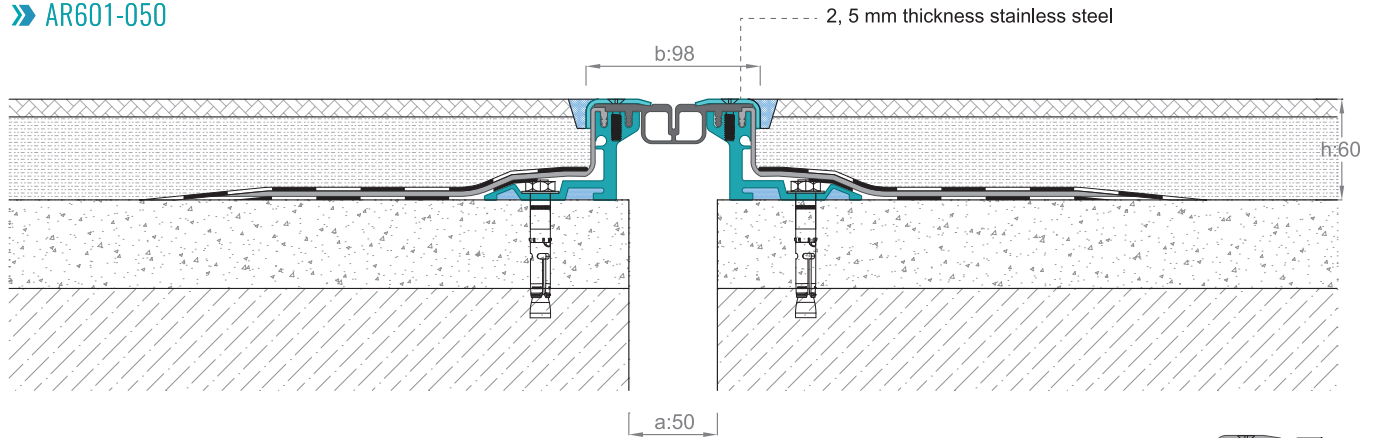

Hygienic gasket alternative

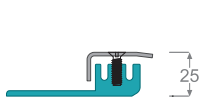

» AR600-050A

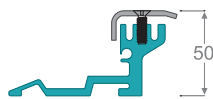

» AR600-050



» AR601-050



» AR602-050



» AR603-050

» AR601-050 SS

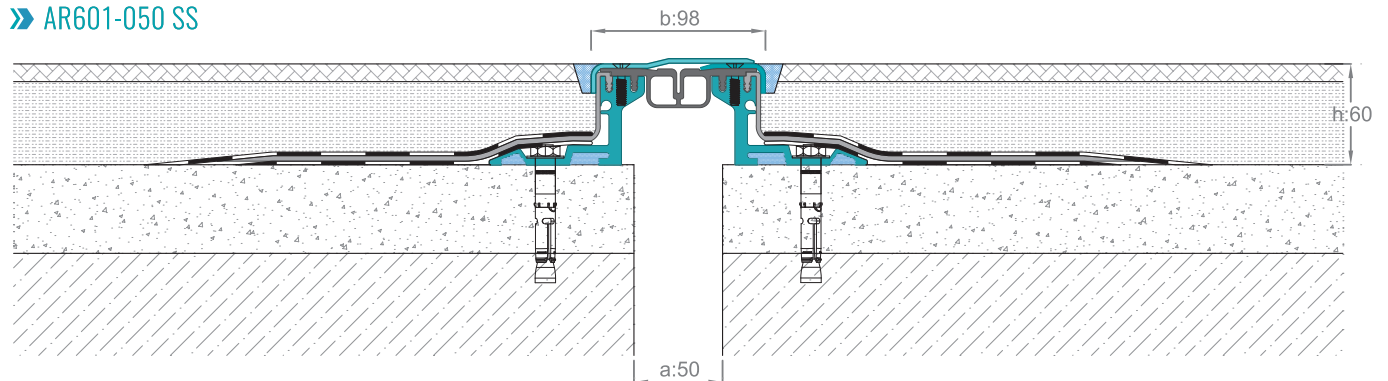

SS 304 quality stainless steel being used. Adoptable with rubber mixture bitumen membrane.

PRODUCT CODE	DESCRIPTION	JOINT WIDTH (a) mm	VISIBLE SURFACE (b) mm	PROFILE HEIGHT (h) mm	TOTAL WIDTH (s) mm	SURFACE	MOVEMENT CAPACITY mm	LOAD CAPACITY
AR600-050A	Ideal for ceramic applications	50	97	25	580	TPV + Stainless Steel	± 20	3.5 Ton
AR600-050	Suitable for granite, marble, concrete and etc.	50	98	50	560	TPV + Stainless Steel	± 20	15 Ton 6 Ton
AR600-050 SS	Suitable for granite, marble with stainless steel top surface	50	98	50	560	Stainless Steel	± 20	15 Ton 6 Ton
AR601-050	Suitable for granite, marble, concrete and etc.	50	98	60	540	TPV + Stainless Steel	± 20	15 Ton 6 Ton
AR602-050	Suitable for granite, marble, concrete and etc.	50	98	70	520	TPV + Stainless Steel	± 20	15 Ton 6 Ton
AR603-050	Suitable for granite, marble, concrete and etc.	50	98	100	460	TPV + Stainless Steel	± 20	15 Ton 6 Ton



» AR601-050 K1

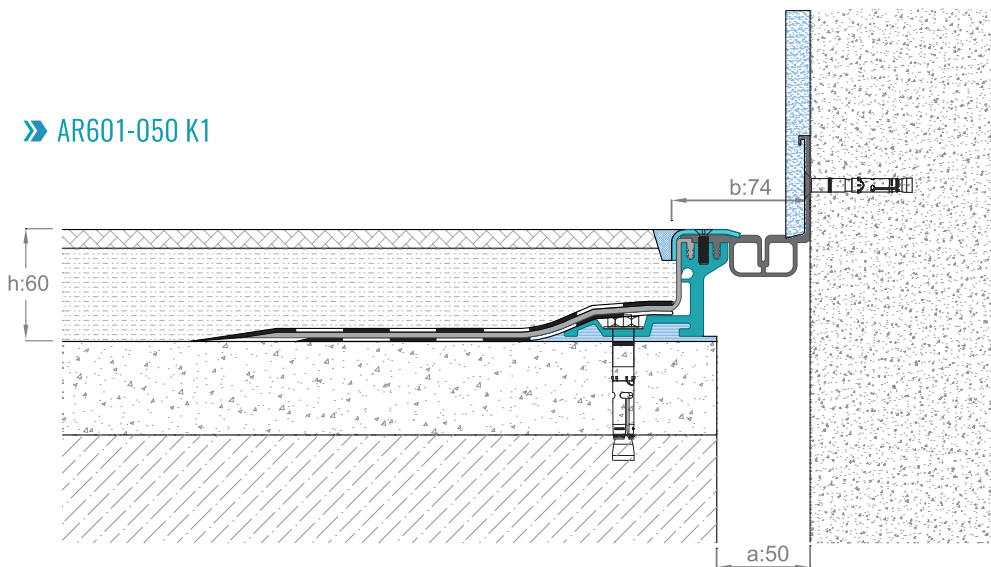

» AR601-050 K2

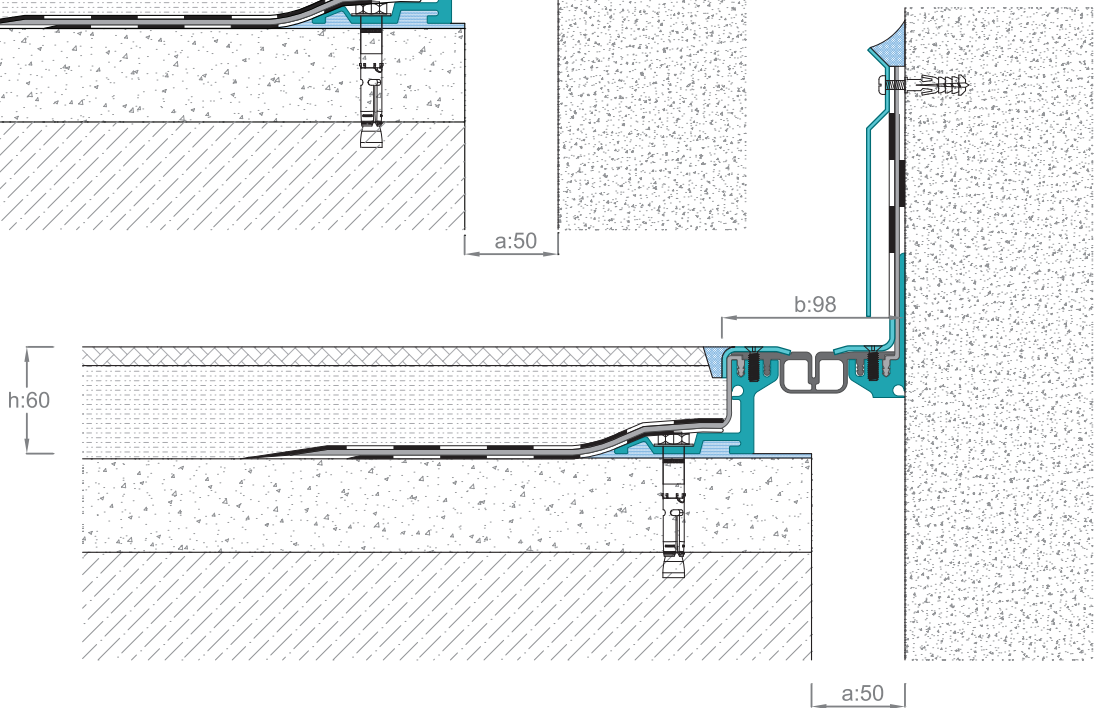

WATERTIGHT
AND TERRACE
EXPANSION
JOINT PROFILES

Floor to Floor Thermoplastic side winged Expansion Joint Profiles are composite of aluminium and stainless steel (SS304). Materials hygienic and complete watertight floor expansion joint profiles are connected to isolation materials by side wings and used in wet areas and terraces. Profiles produced in 3 meters lengths and gaskets in 15 meters by rolls.

APPLICATIONS



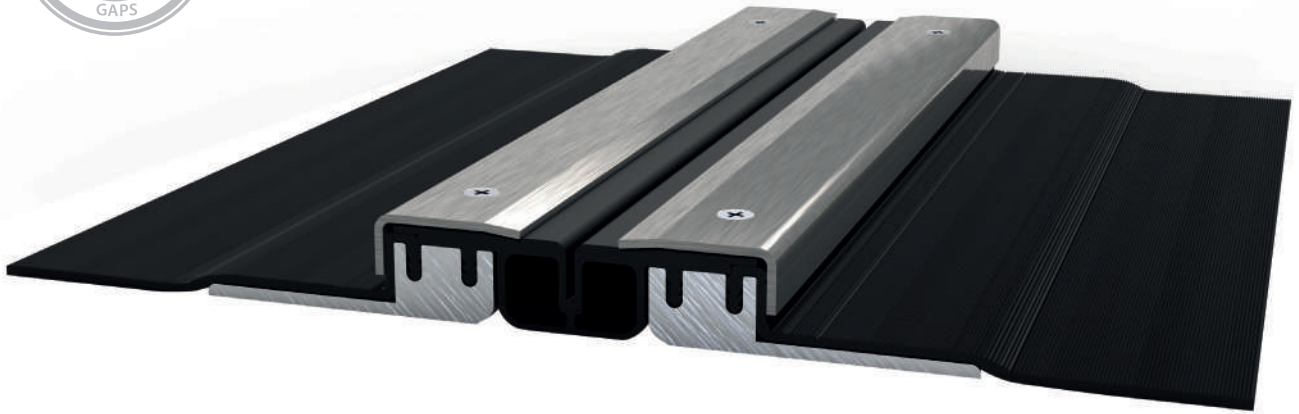

» AR600-050 A

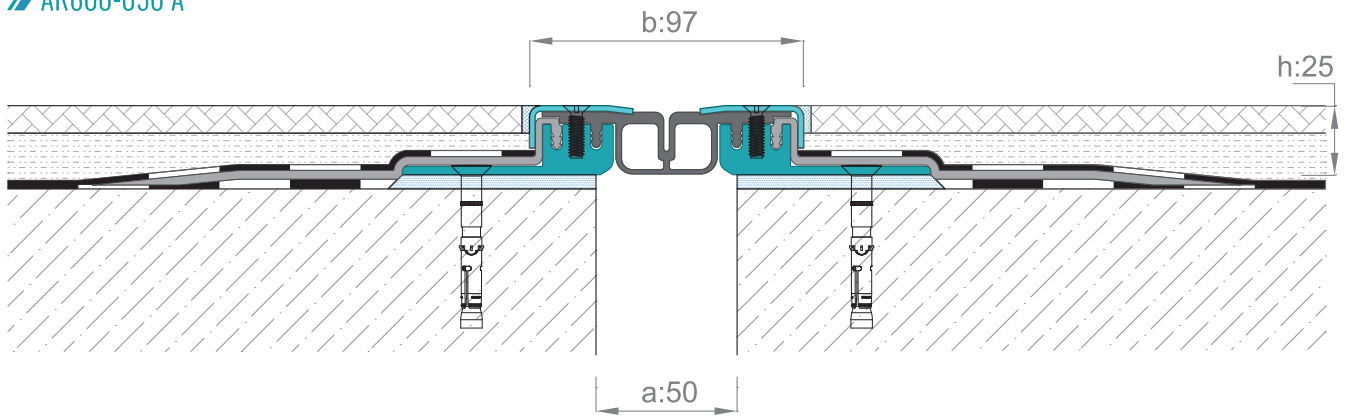

» AR600-050 A2

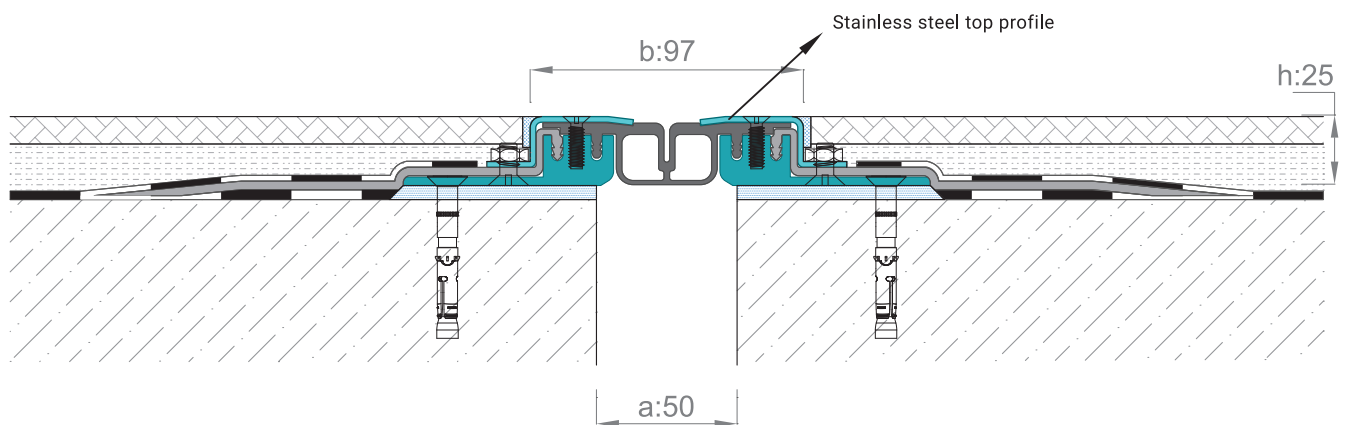

APPLICATIONS



These Flush mounted and TPE inserted Expansion joint Profiles used for wet areas and terraces with low covering height.

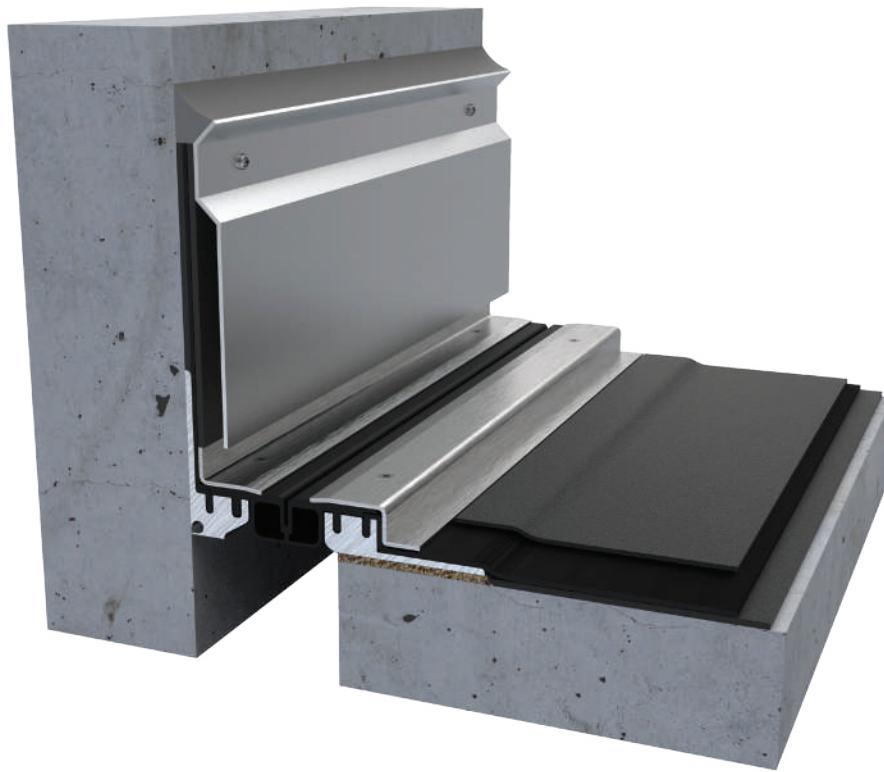

» AR600-050 AK1

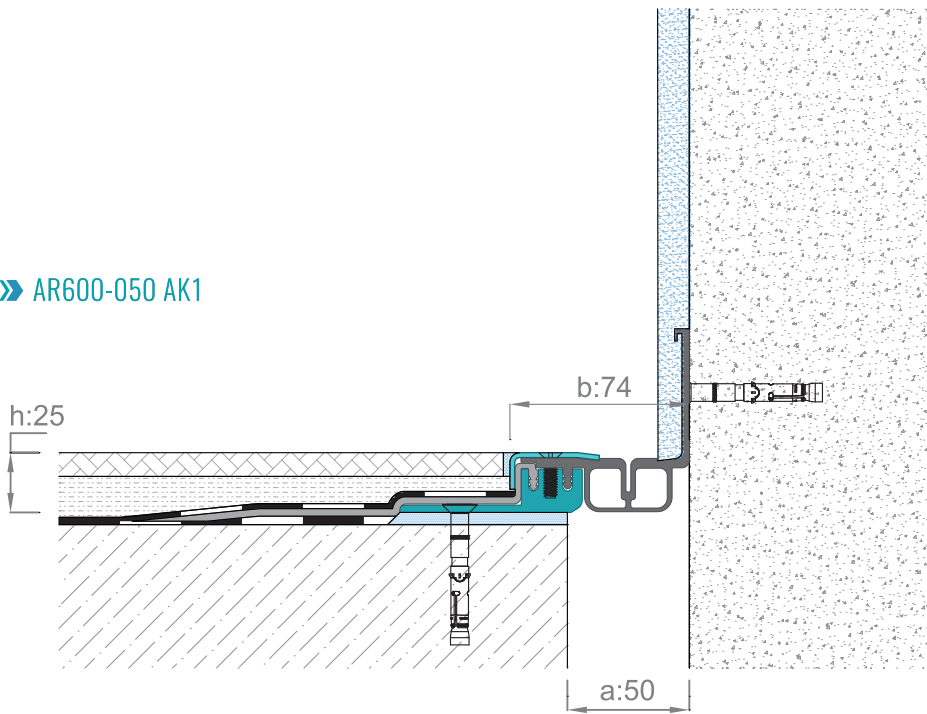

» AR600-050 AK2

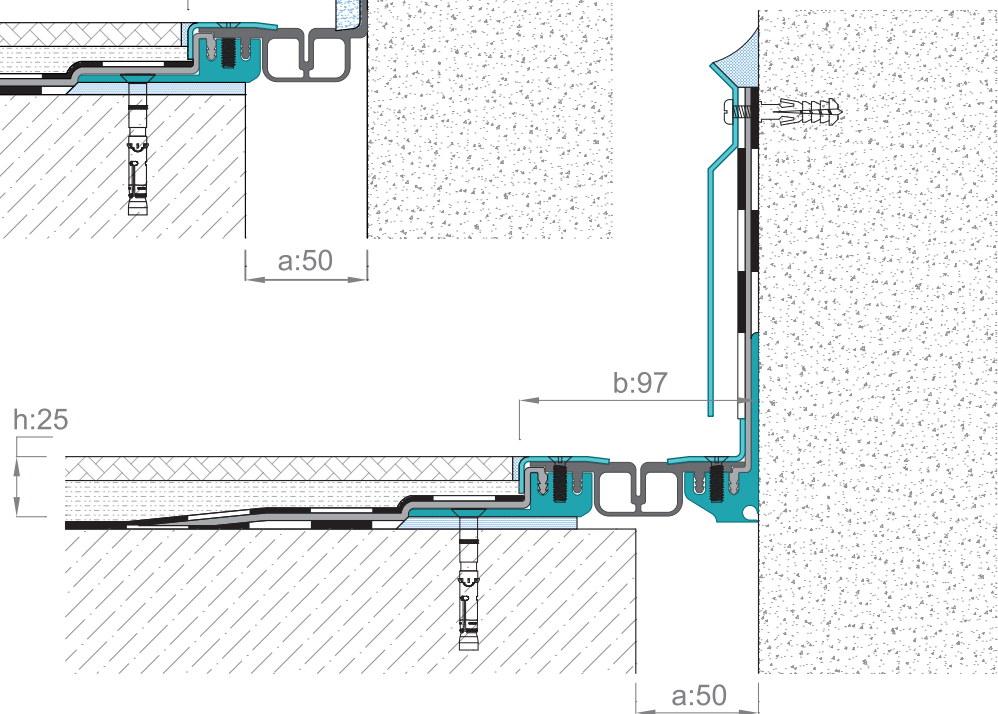

WATERTIGHT
AND TERRACE
EXPANSION
JOINT PROFILES

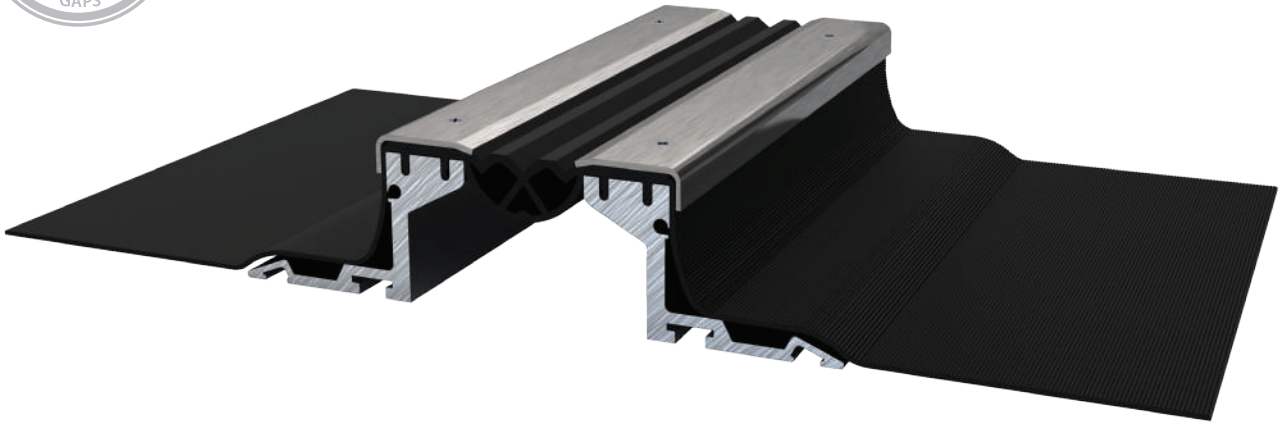

» AR600-100

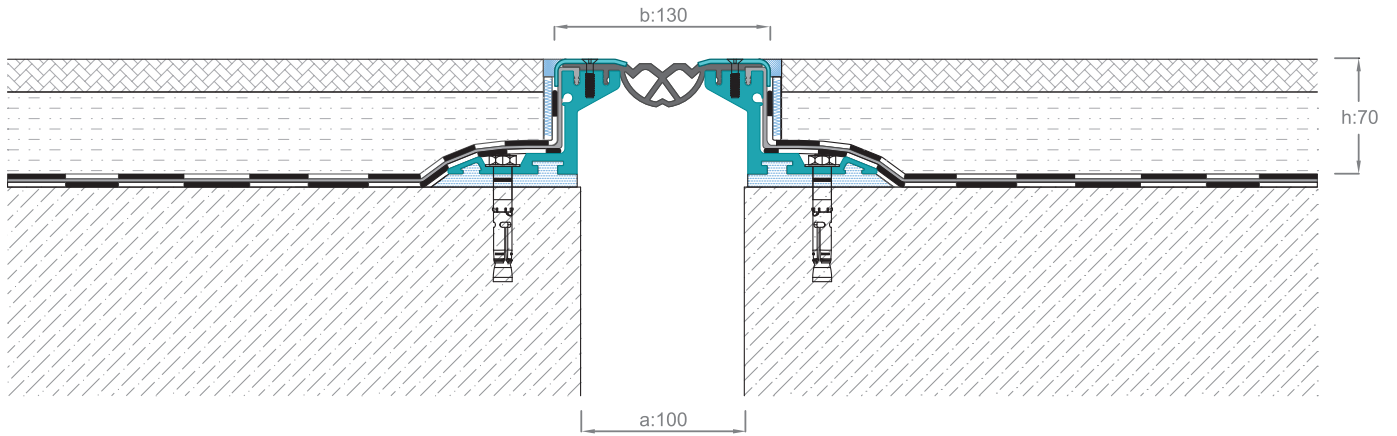

» AR600-100 SS

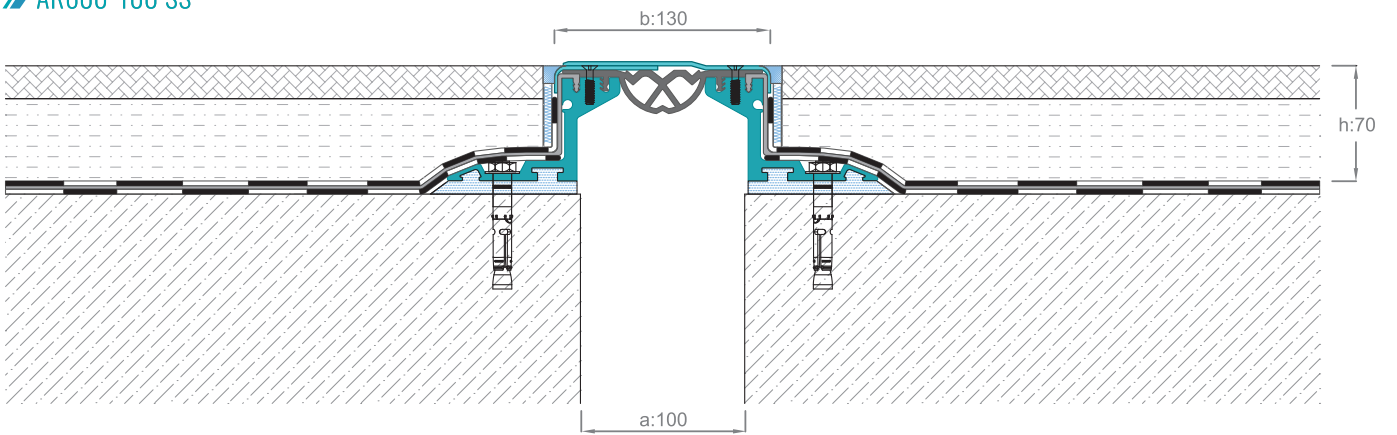

Economic stainless steel top surfaced flush mounted expansion joint profiles are used for 100 mm joint gaps. Additionally, suitable with rubber mixture bitumen membrane.

PRODUCT CODE	DESCRIPTION	JOINT WIDTH (a) mm	VISIBLE SURFACE (b) mm	PROFILE HEIGHT (h) mm	TOTAL WIDTH (s) mm	SURFACE	MOVEMENT CAPACITY mm	LOAD CAPACITY
AR600-100	Suitable for granite, ceramic, concrete and etc.	100	130	70	580	TPV+Stainless Steel	± 20	9 Ton 3.5 Ton
AR600-100 SS	Suitable for granite, marble and etc. with S. Steel top surface	100	130	70	580	Stainless Steel	± 20	9 Ton 3.5 Ton

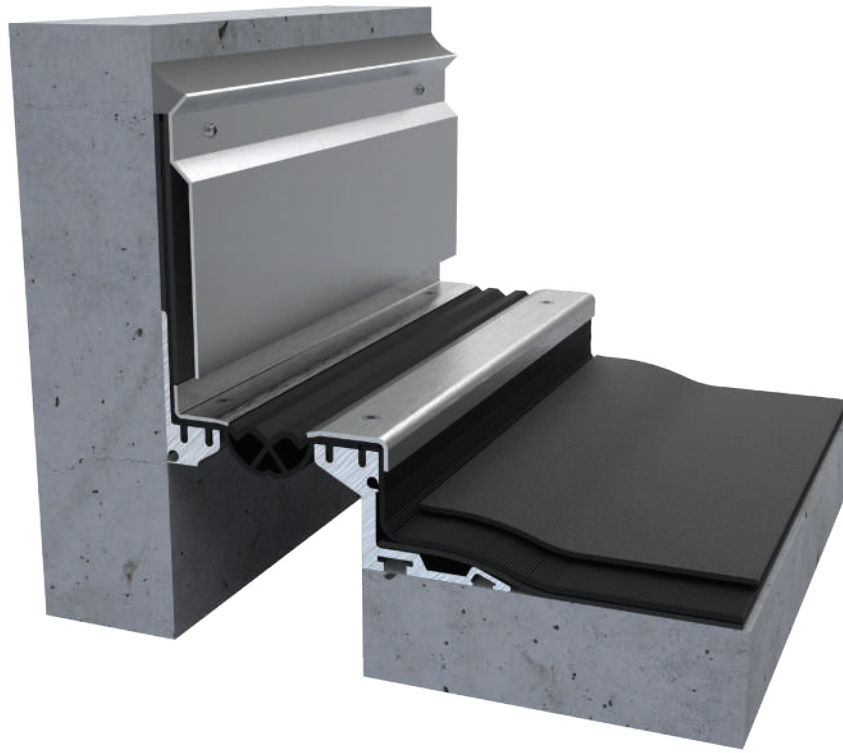

» AR600-100K

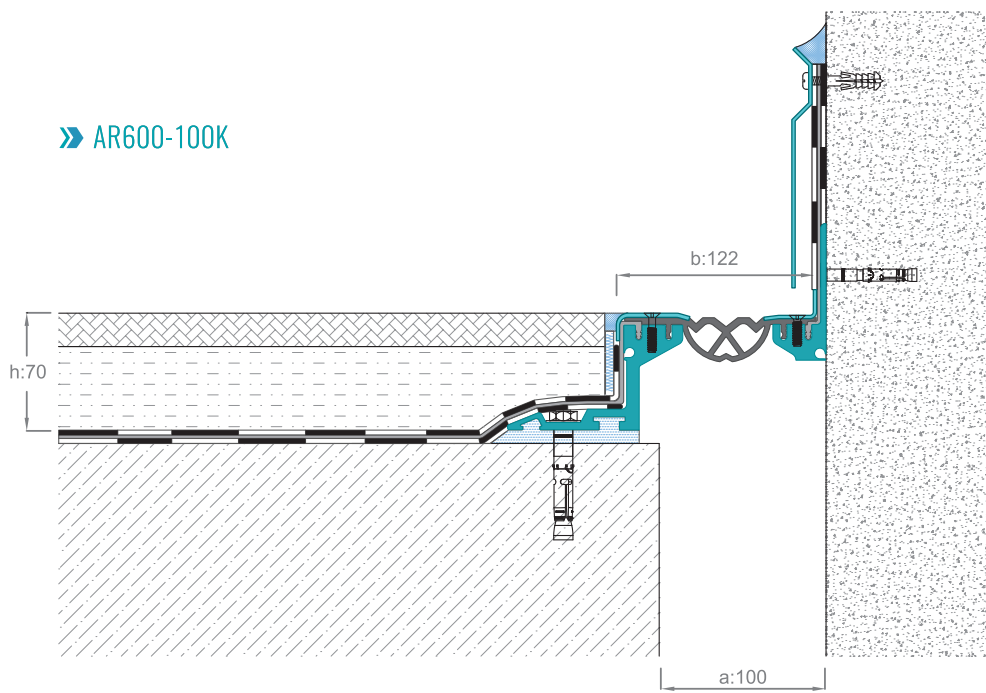

» AR600-100 SSK

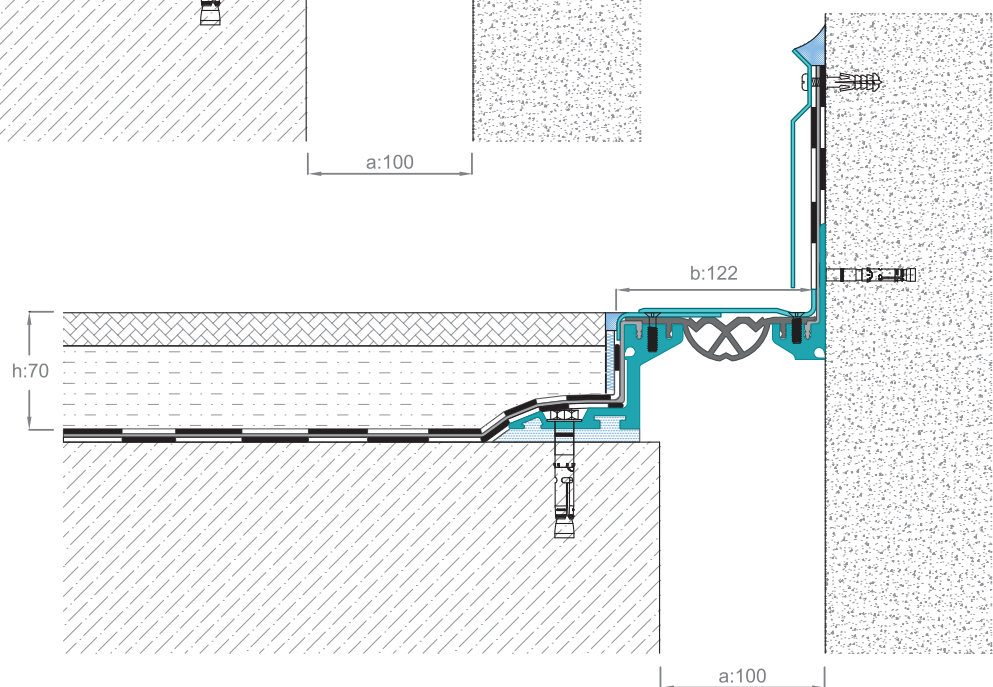

WATERTIGHT
AND TERRACE
EXPANSION
JOINT PROFILES

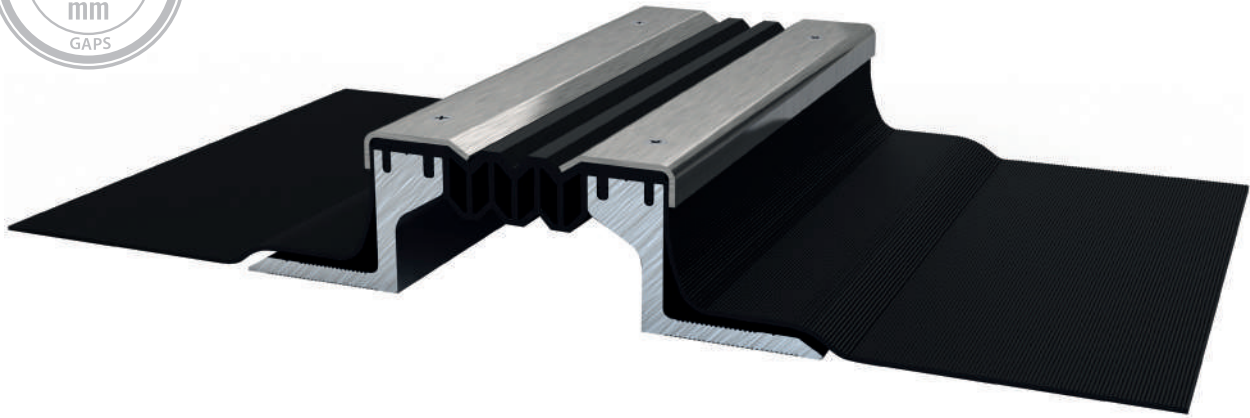

» AR600-101

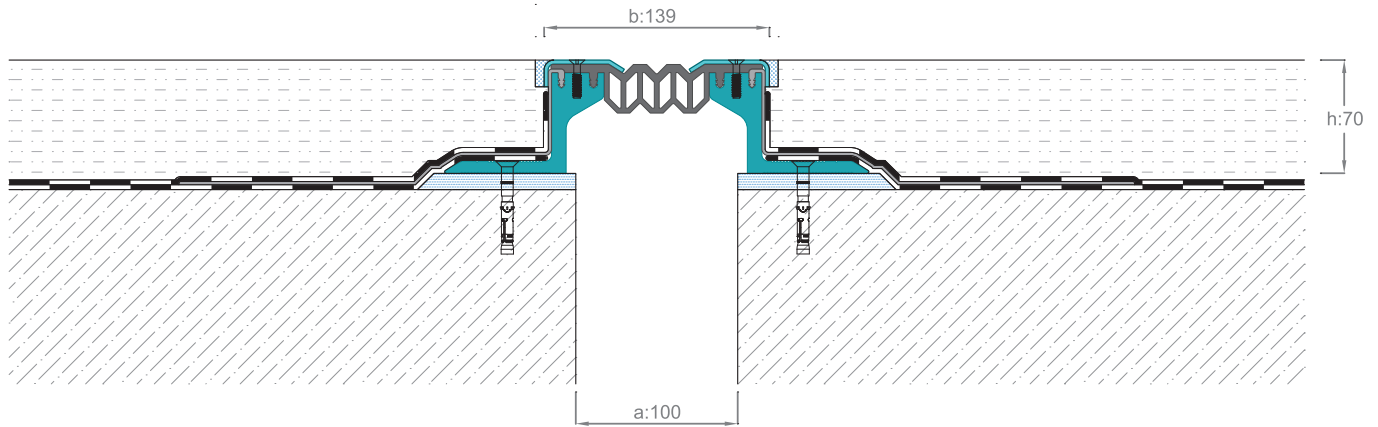

» AR600-101 SS

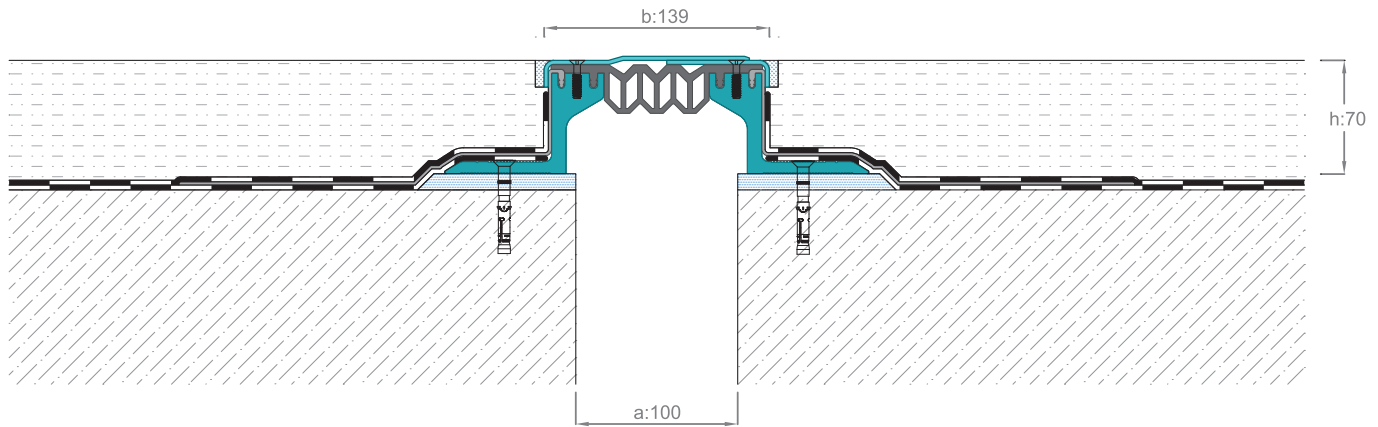

TPE inserted and completely watertight Expansion Joint Profiles have the high capacity to move. Mechanical damages (screws and etc.) are prevented by hygienic top surface and TPE insert. The alternative complete stainless steel option is also available.



APPLICATIONS

PRODUCT CODE	DESCRIPTION	JOINT WIDTH (a) mm	VISIBLE SURFACE (b) mm	PROFILE HEIGHT (h) mm	TOTAL WIDTH (s) mm	SURFACE	MOVEMENT CAPACITY mm	LOAD CAPACITY
AR600-101	Suitable for granite, marble, ceramic, concrete and etc.	100	139	70	590	TPV+Stainless Steel	± 30	15 Ton 6 Ton
AR600-101 SS	Suitable for granite, marble and etc. with Stainless steel top surface	100	139	70	590	Stainless Steel	± 30	15 Ton 6 Ton
AR600-150	Suitable for granite, marble, ceramic, concrete and etc.	150	184	70	630	TPV+Stainless Steel	± 50	15 Ton 6 Ton
AR600-150SS	Suitable for granite, marble and etc. with Stainless steel top surface	150	184	70	630	Stainless Steel	± 50	15 Ton 6 Ton
AR600-200	Suitable for granite, marble, ceramic, concrete and etc.	200	234	70	680	TPV+Stainless Steel	± 50	9 Ton 3.5 Ton
AR600-200SS	Suitable for granite, marble and etc. with Stainless steel top surface	200	234	70	680	Stainless Steel	± 50	9 Ton 3.5 Ton

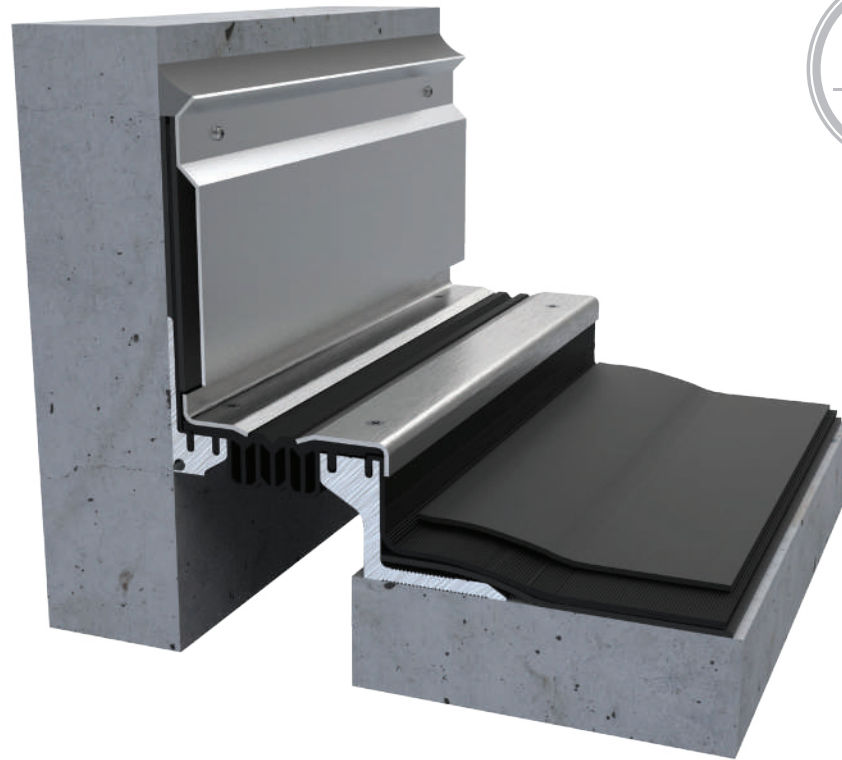

» AR600-101 K

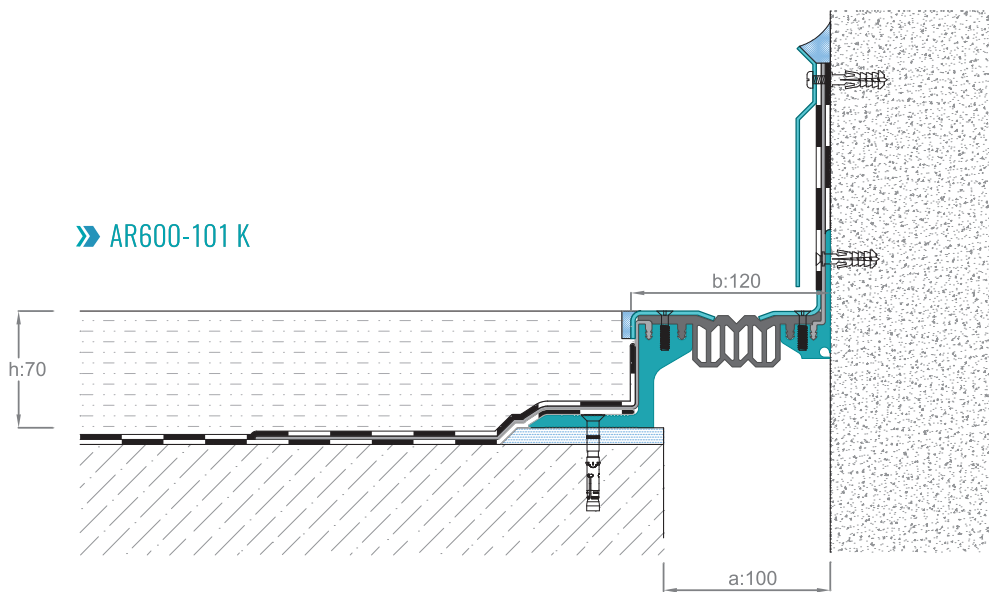

» AR600-101 SSK

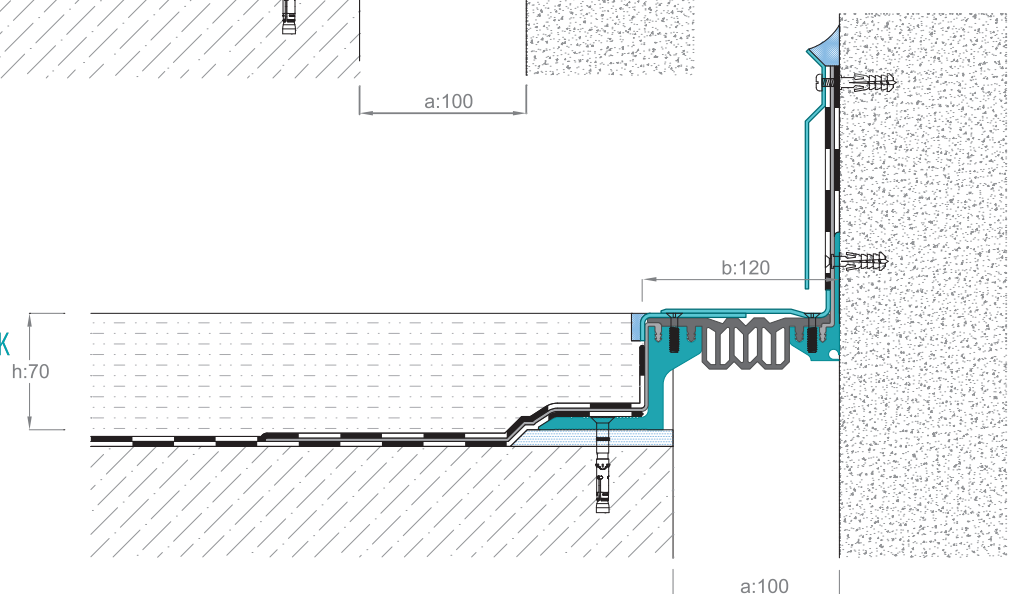

WATERTIGHT
AND TERRACE
EXPANSION
JOINT PROFILES

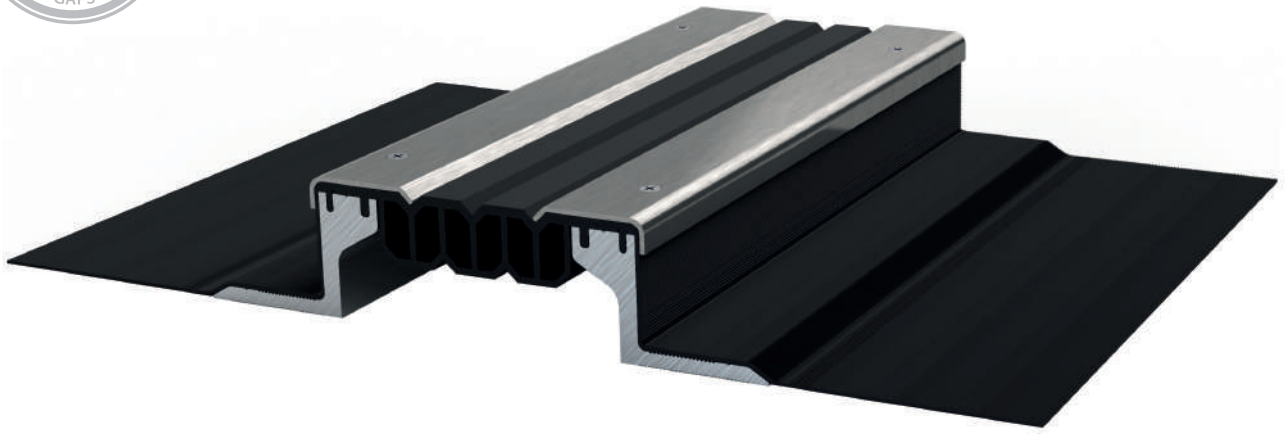

» AR600-150

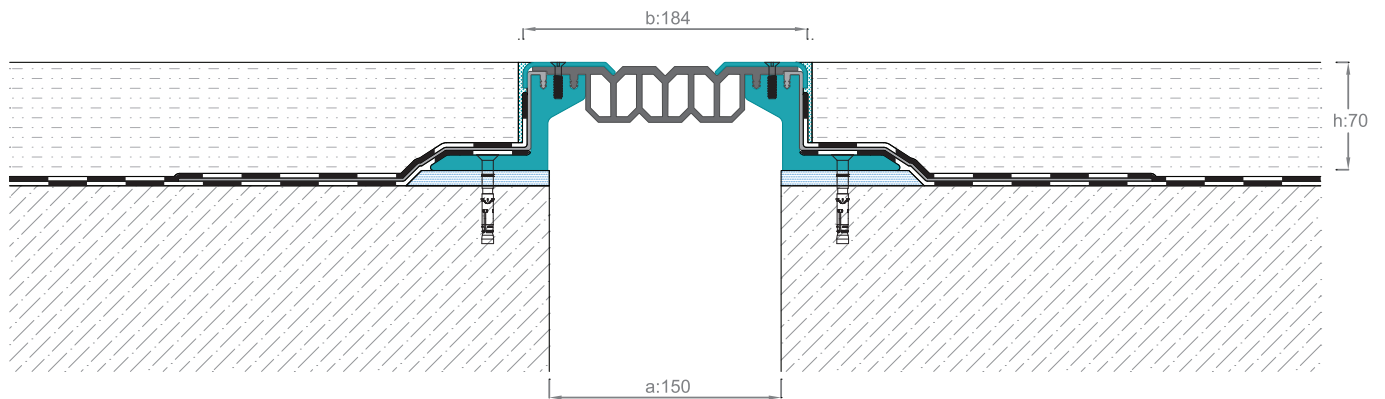

» AR600-150 SS

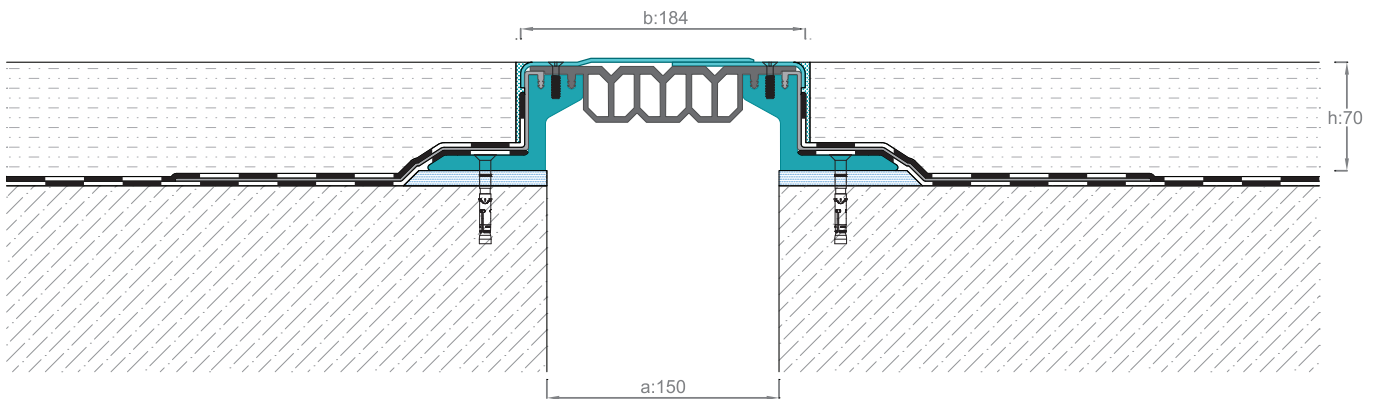

Flush mounted floor and completely watertight Expansion Joint Profiles are suitable for 15 cm gaps and resistant to heavy loads by having special TPE insert in the middle. They can comfortably be used in open and closed areas. Connection of T and L details are also available. Movement capacity and load capacity details can be found in page 85.



APPLICATIONS



» AR600-150 K

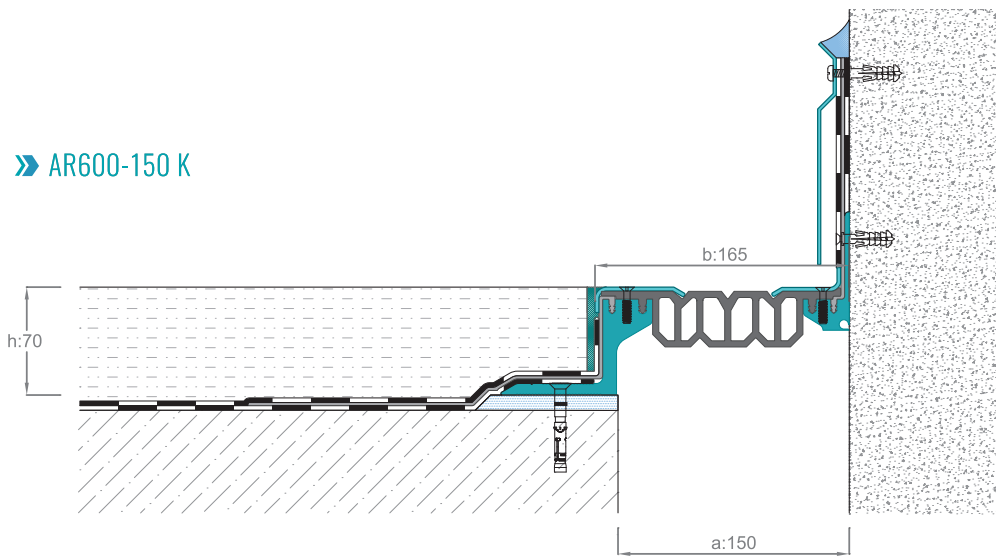

» AR600-150 SSK

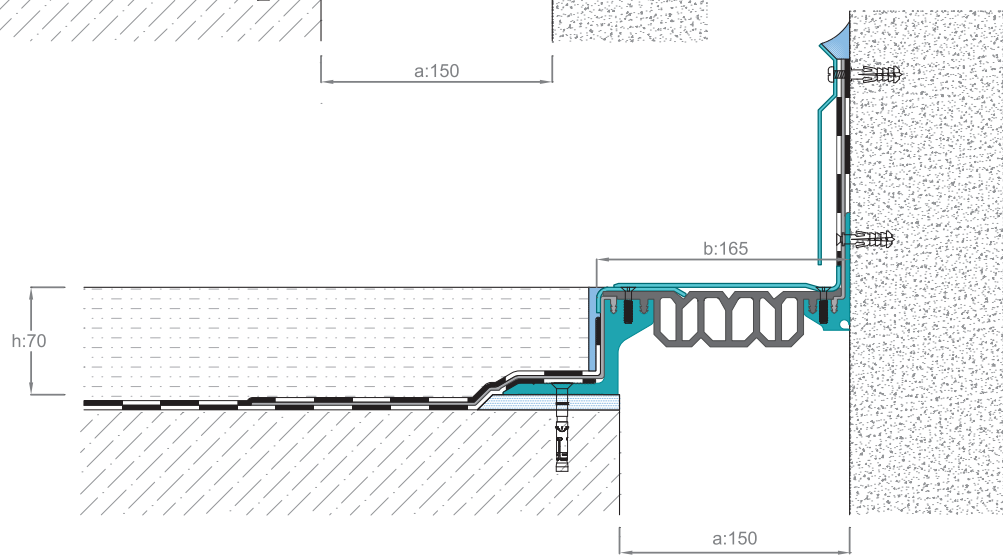

WATERTIGHT
AND TERRACE
EXPANSION
JOINT PROFILES

Additional bits can be melted by only using hot air supply and does not require any other extra source.

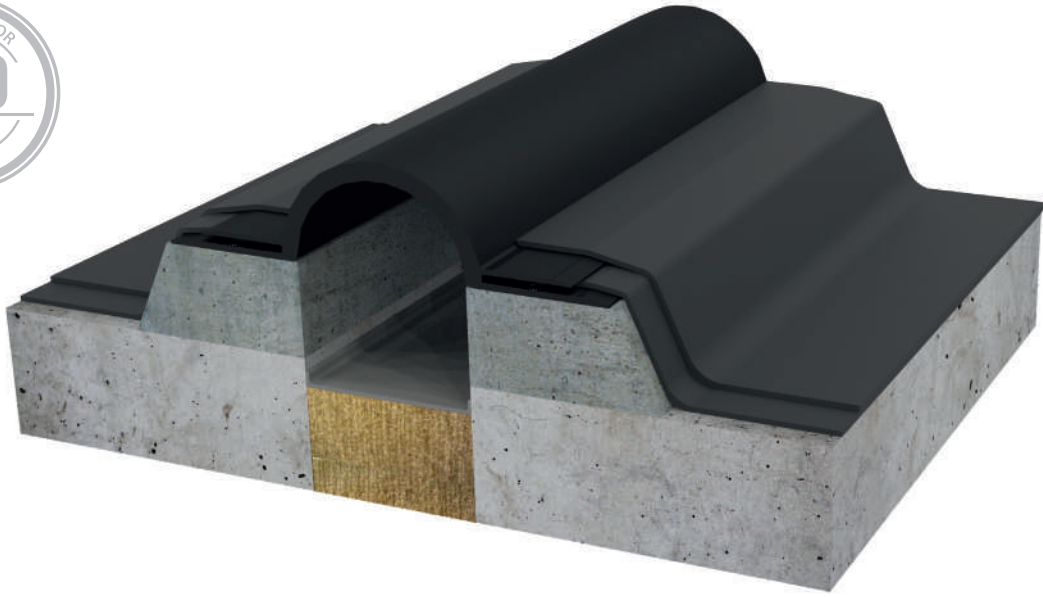

» AR500-101

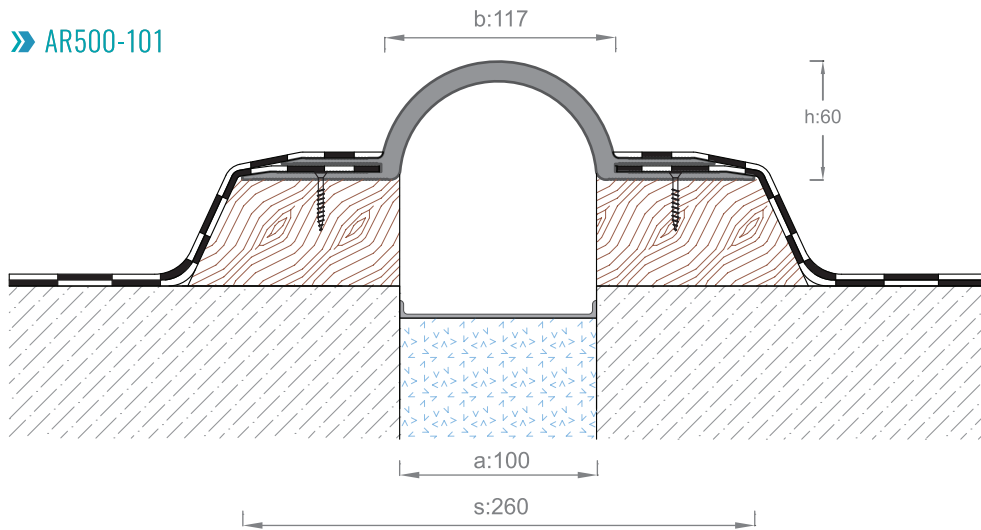

» AR500-101 CORNER DETAIL

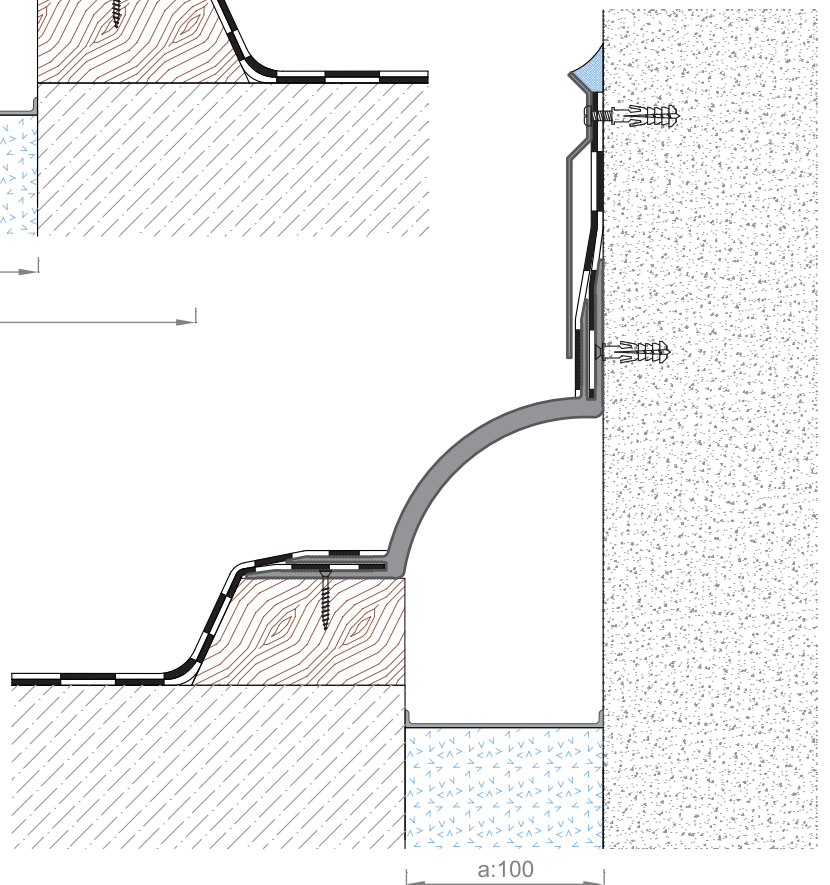

10 mm thick omega terrace thermoplastic bands are resistant to impacts and tearing risks with its strong middle part. Produced in 15 meter lengths.



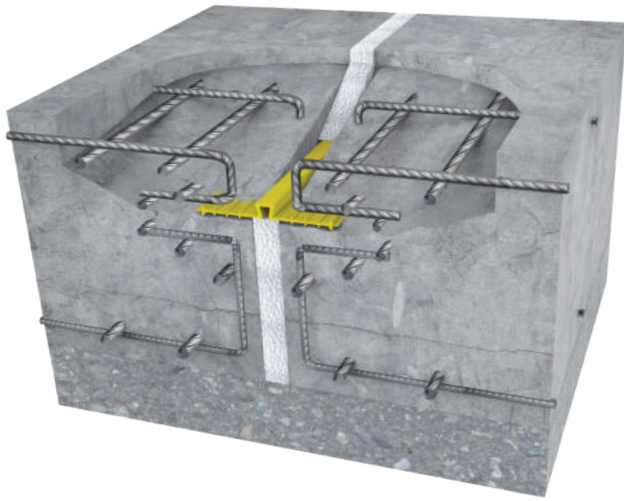

» AR500-030

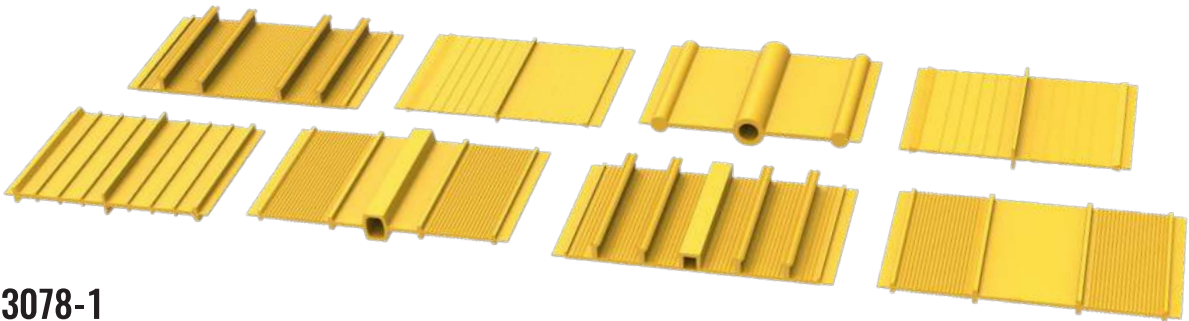
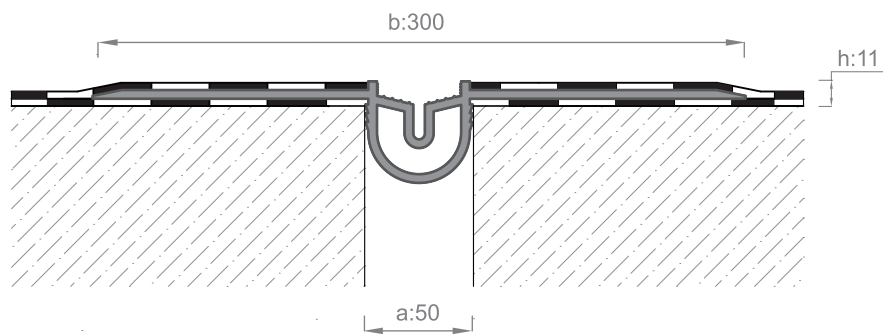

TS 3078-1

November 2018 -Turkish Standard



WATERTIGHT AND TERRACE EXPANSION JOINT PROFILES

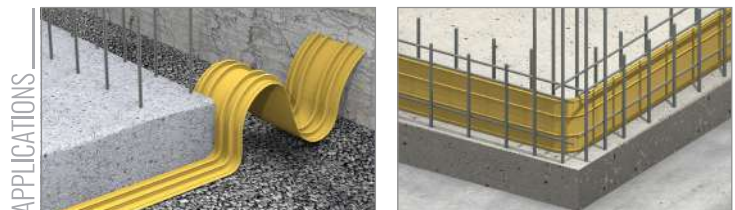

APPLICATIONS

ARFEN's different typed and dimensioned watertight bands are suitable for International standards and Turkish standards. Utilized in foundation to retaining wall, foundation to foundation and retaining wall to retaining wall. Delivered in 25 meters length as a roll.

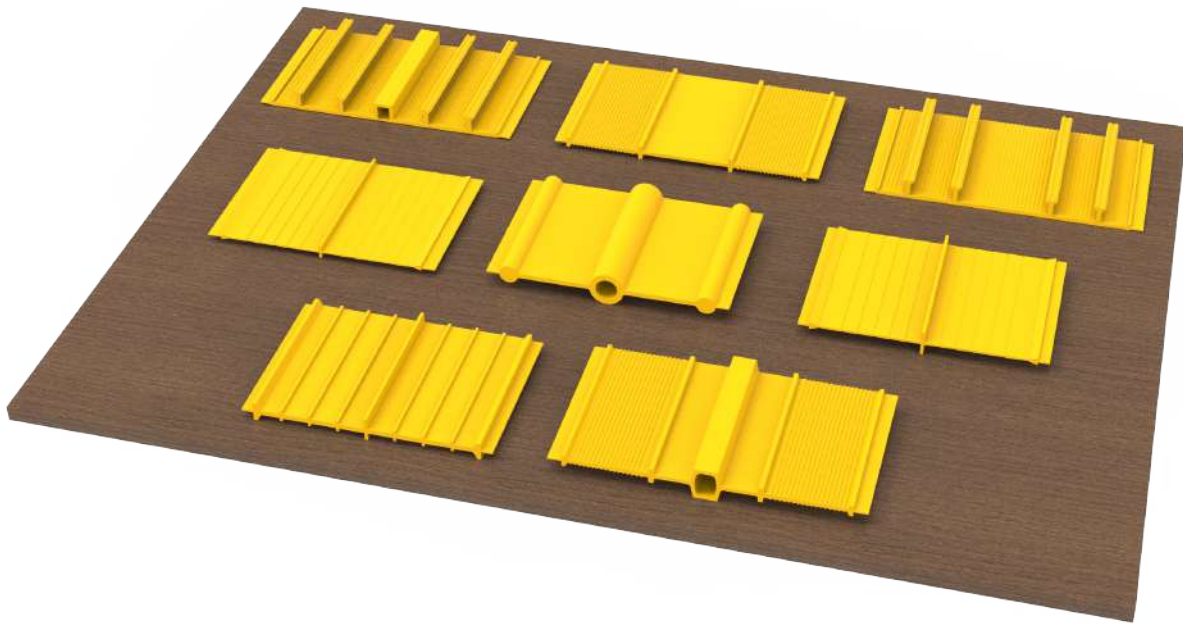

Purpose of use: For several reasons (settlement, earthquake and etc.) many structures face with horizontal or vertical gaps. To maintain watertightness in these gaps ARFEN's PVC watertight bands are applied.

Material: Extruded by maintaining appropriate temperature and pressure using mixture of Polyvinyl chloride (PVC) resin, various catalysts, stabilizer, antioxidants, stain, hardener and plasticizer.

» APPLICATION AREAS

Hydraulic power plants, Bridges, Underground constructions, Viaducts, Retaining walls, Flooring and bases sitting on the ground, hydraulic power stations, underground water below the groundwater level, Drainage, Water reservoirs, Reservoirs, Water treatment facilities, Swimming pools, Waterfalls, curtain compositions, Industrial constructions.

» TECHNICAL SPECIFICATION

Tensile strength	Average value	Min. 14	N/mm ²
	The smallest value	Min. 12	N/mm ²
Stretching capacity	Average value	Min. 225	%
	The smallest value	Min. 200	%
Type A Shore durometer Hardness grade		75±5	Shore "A"
Unit volume of mass (density)		1,27±0,04	g/cm ³
Mass to water absorption ratio		Max. 1,5	%
Mass to ash ratio suture		Max. 5,0 (m/m)	%

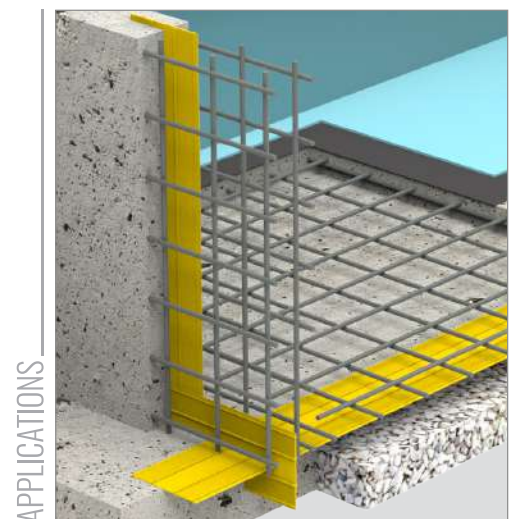
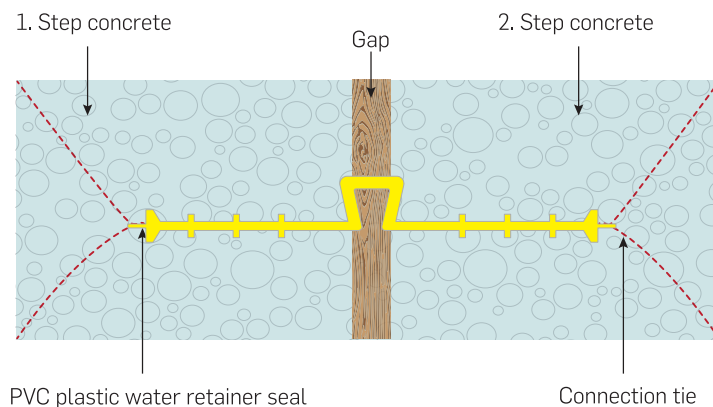

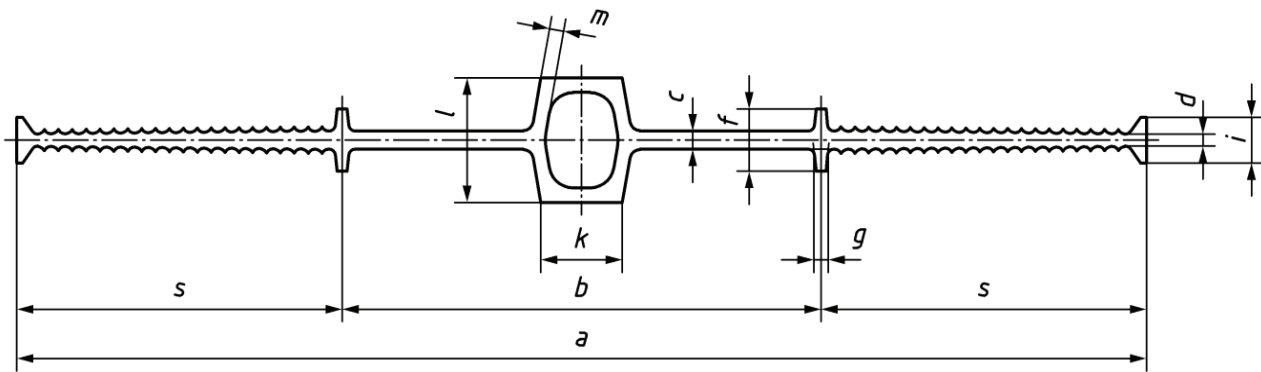

- a** Total width
- b** Expansion area width
- c** Thickness of the thinnest part in expansion area
- d** Thickness of the thinnest part in fastening area
- f** Height of flat anchoring (fastening) nail
- g** Width of the anchoring nail
- i** Thickness of side anchoring bit
- k** Expansion gap width
- s** Width of fastening area - Middle axis
- m** Thickness of the thinnest part in expansion gap area
- l** Height of expansion gap area

Type	Width			Thickness	Profile					Expansion Gap			
	a	b	s		c	d ^a	f	g	i	k	l	m ^b	
D 	Minimum	Minimum	Minimum	Minimum	Minimum	Minimum	Minimum	Minimum	Minimum	Minimum	Minimum	Minimum	
	240	80	62,5	4	3	15	≥ c	11 ≥ d + 6	20	30	3,5		
	320	100	75	5	3,5	≥ 3 c				35	4		
	500	150	100	6	4,5	18 ≥ 3 c				45	4,5		
A 	Width			Thickness		Profile							
	a	b	s	c	d ^a	f	g	i					
	Minimum	Minimum	Minimum	Minimum	Minimum	Minimum	Minimum	Minimum	Minimum				
	240	80	62,5	3,5	2,5	15	≥ c	11 ≥ d + 6					
320	100	75	4,5	3	≥ 3 c								
500	150	100	6	3,5	18 ≥ 3 c								
DA 	Width		Thickness	Profile						Expansion Gap			
	a	b	c	N	e	f	f ₁ ^a	g	h	i	k	l	m
	Minimum	Minimum	Minimum	Minimum	Minimum	Minimum	Minimum	Minimum	Minimum	Minimum	Minimum	Minimum	Minimum
	240	90	4	4	45	20	16	4	4	11 ≥ h + 6	20	20	4
320	100	6		25		21	≥ c						
500	120	8		25		21	≥ 0,2 f						
AA 	Width		Thickness	Profile									
	a	b	c	N	e	f	f ₁ ^a	g	h	i			
	Minimum	Minimum	Minimum	Minimum	Minimum	Minimum	Minimum	Minimum	Minimum	Minimum			
	240	80	4	4	45	20	16	4	4	11 ≥ h + 6			
320	100	6		25		21	≥ c						
500	150	8		25		21	≥ 0,2 f						

WATERTIGHT
 AND TERRACE
 EXPANSION
 JOINT PROFILES



» AR605-100

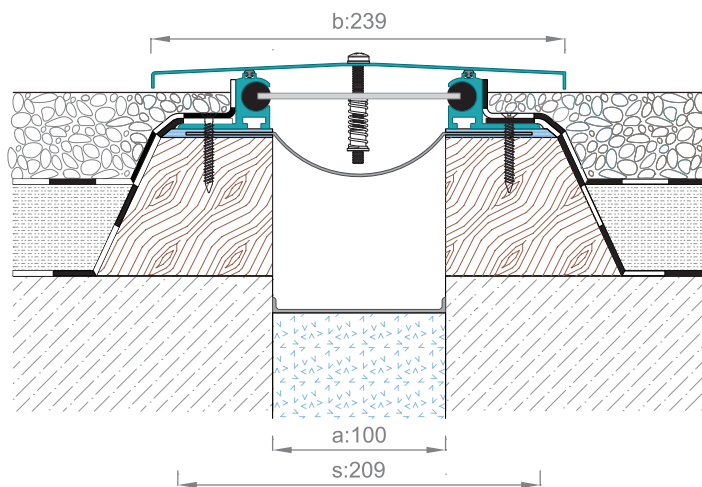

» AR605-100K

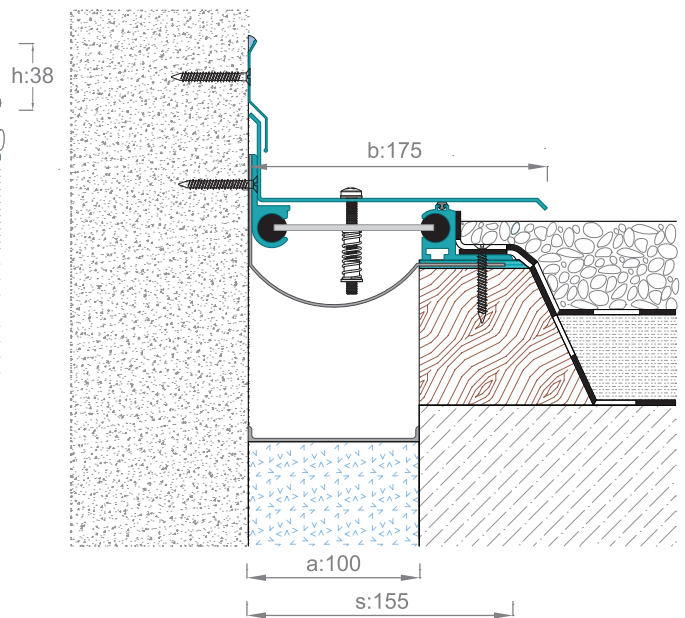

Coping type Terrace Expansion Joint Profiles are used as protectors and isolators in opened terraces. Applied with bitumen absorbed wooden wedges or dilatation concrete. H profiles are fitted in additional places to achieve complete watertightness.



PRODUCT CODE	DESCRIPTION	JOINT WIDTH (a) mm	VISIBLE SURFACE (b) mm	PROFILE HEIGHT (h) mm	TOTAL WIDTH (s) mm	SURFACE	MOVEMENT CAPACITY mm
AR 605 - 050	Coping profiles for terrace applications	50	189	38	189	Anodised Alu./ Powder coated paint	± 25
AR 605 - 100	Coping profiles for terrace applications	100	239	38	239	Anodised Alu./ Powder coated paint	± 50
AR 605 - 150	Coping profiles for terrace applications	150	289	38	289	Anodised Alu./ Powder coated paint	± 75
AR 605 - 200	Coping profiles for terrace applications	200	339	38	339	Anodised Alu./ Powder coated paint	± 100
AR 605 - 250	Coping profiles for terrace applications	250	389	38	389	Anodised Alu./ Powder coated paint	± 100
AR 605 - 300	Coping profiles for terrace applications	300	439	38	439	Anodised Alu./ Powder coated paint	± 100

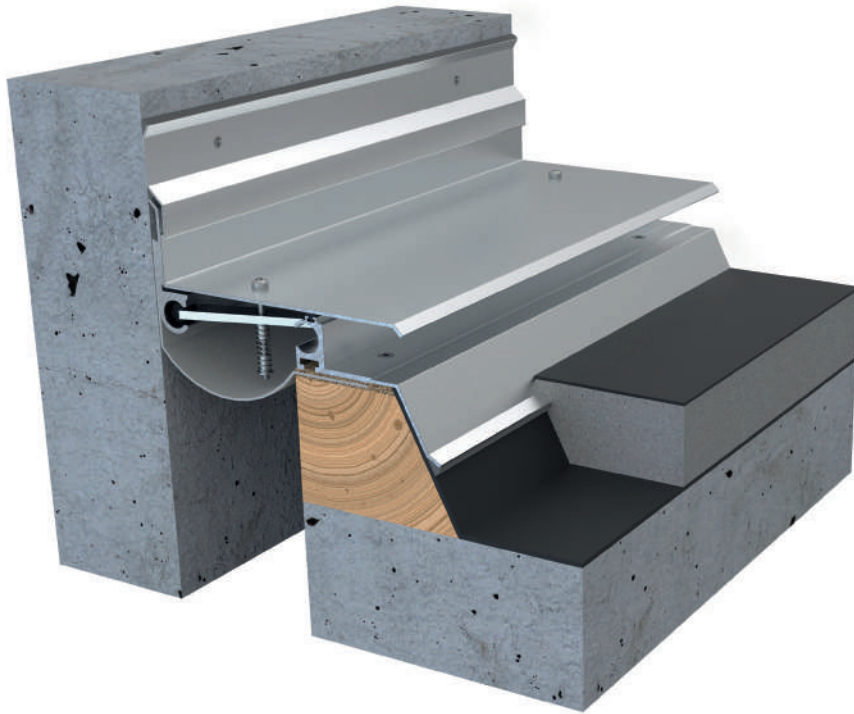

» AR605-101

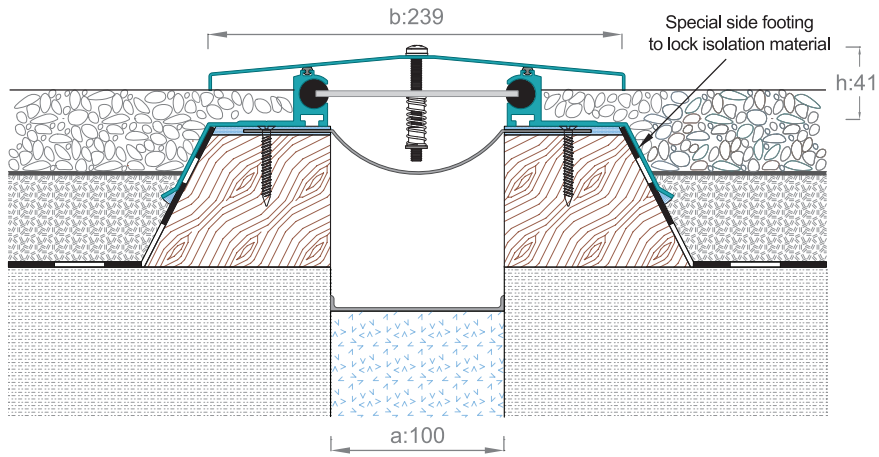

» AR605-101K

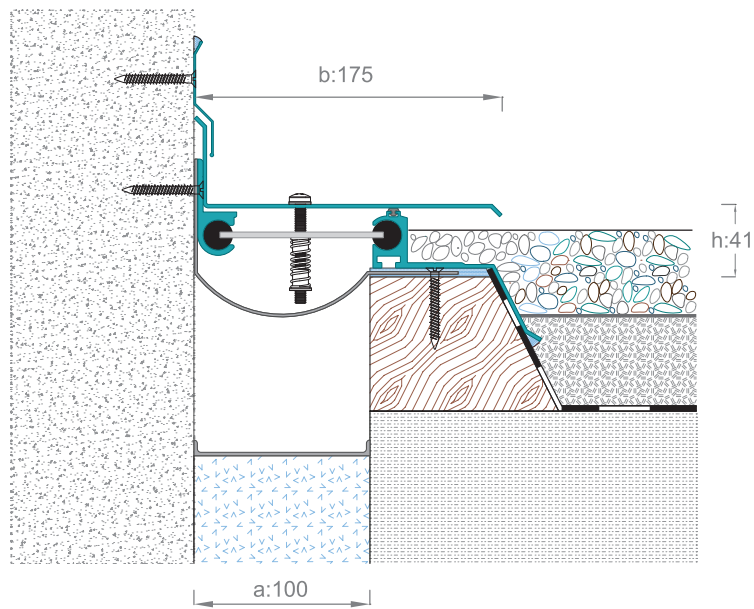

WATERTIGHT
AND TERRACE
EXPANSION
JOINT PROFILES

APPLICATIONS



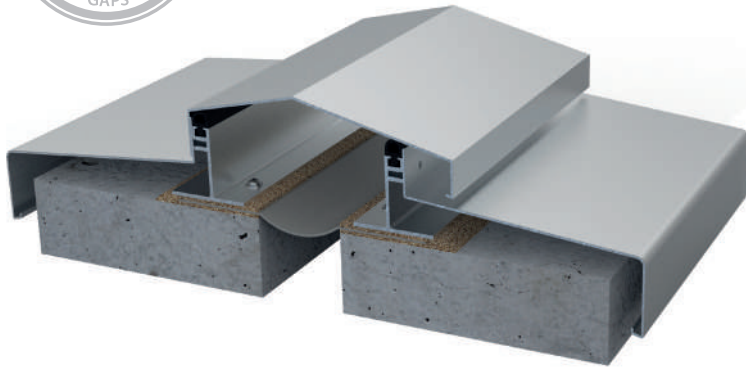

» AR606-050

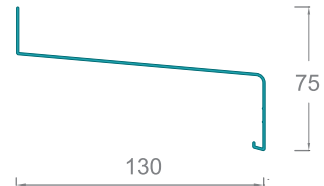
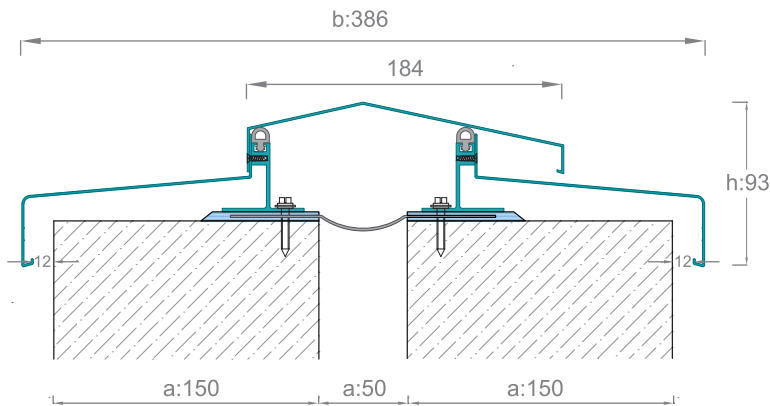

AR 606-050 15 CM PARAPET

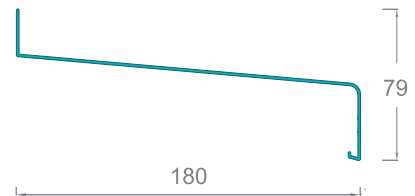

AR 606-051 20 CM PARAPET

» AR606-050K

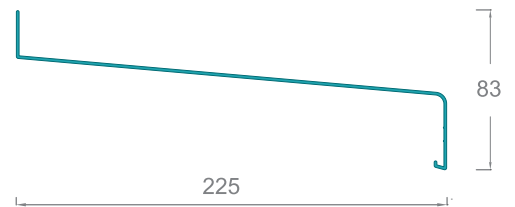
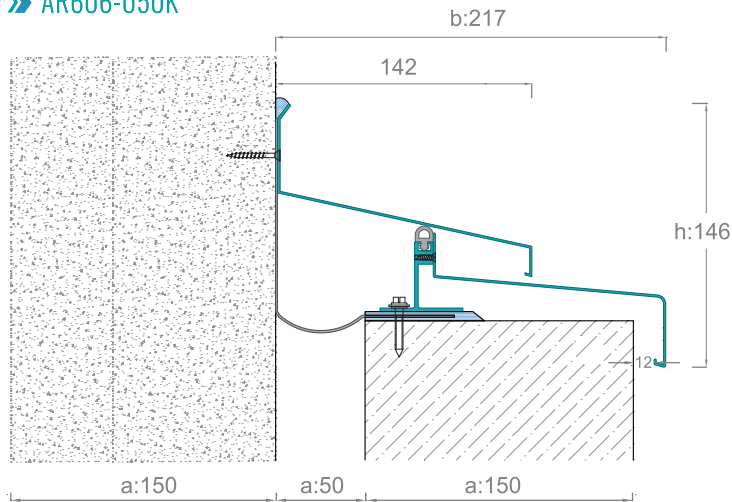

AR 606-052 25 CM PARAPET

Terrace Coping Profiles bottom footing can be produced according to the gap dimensions. Watertightness can be obtained by TPE H profile.

PRODUCT CODE	DESCRIPTION	JOINT WIDTH (a) mm	VISIBLE SURFACE (b) mm	PROFILE HEIGHT (h) mm	TOTAL WIDTH (s) mm	SURFACE	MOVEMENT CAPACITY mm
AR 606 - 050	Coping profiles for terrace applications	50	386	93	386	Anodised Alu./ Powder coated paint	± 25
AR 606 - 100	Coping profiles for terrace applications	100	436	93	436	Anodised Alu./ Powder coated paint	± 50
AR 606 - 150	Coping profiles for terrace applications	150	486	93	486	Anodised Alu./ Powder coated paint	± 50
AR 606 - 200	Coping profiles for terrace applications	200	536	93	536	Anodised Alu./ Powder coated paint	± 50
AR 606 - 250	Coping profiles for terrace applications	250	586	93	586	Anodised Alu./ Powder coated paint	± 50
AR 606 - 300	Coping profiles for terrace applications	300	636	93	636	Anodised Alu./ Powder coated paint	± 50

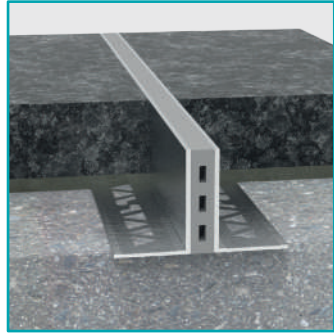
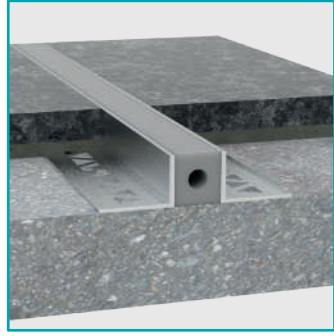
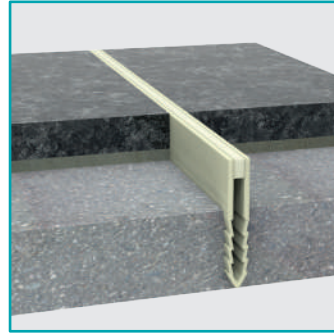
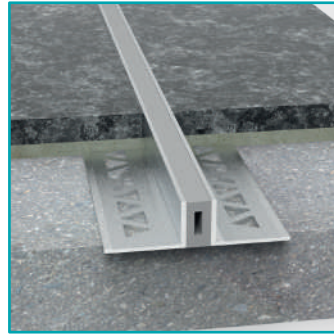

movement joint profiles

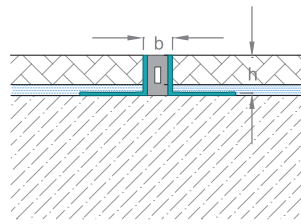
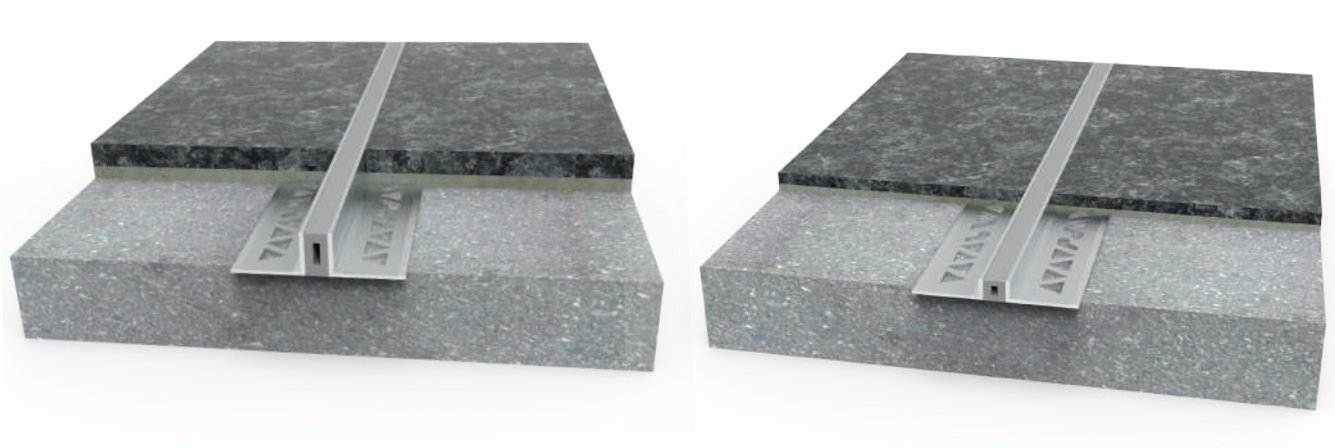

» DP 01-06

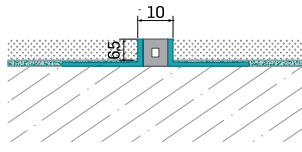

» DP 01-08

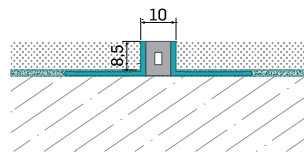

» DP 01-10

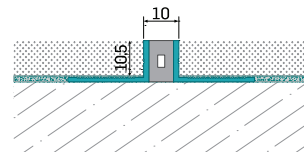

» DP 01-12

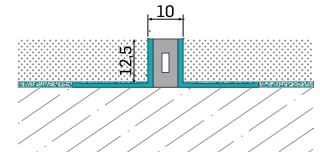

» WHY MOVEMENT JOINT PROFILES ARE USED?

Ceramic, granite, porcelain, stone, glassy ceramics, concrete and marble tiles and terrazzo floor cover applications require thermal expansion joints profiles to absorb natural movements. The temperature difference causes expansion and shrinkage in water or moisture coatings thus, all the tiles shrink with drying and cooling. Another reason, dynamic structural loads cause vibration and large movements in the tile applications. If expansion joint is not used in tile, ceramic, granite or marble applications, internal stresses due to expansion or internal shrinkage can cause many problems such as, obvious cracks and breakage. Therefore, joint design extremely significant for the life of the coatings.

» APPLICATION STANDARDS

Application Area	Minimum Application Area m2	Maximum Application Area m2	Movement Joint Width (Elastomer bit)
Internal Areas	4,80 mt * 4,80 mt	6,00 mt * 6,00 mt	6 mm
Internal Areas (Moist and Sun lighted areas)	3,60 mt * 3,60 mt	4,80 mt * 4,80 mt	6 mm
External Areas	2,40 mt * 2,40 mt	3,60 mt * 3,60 mt	10 mm
External Areas (Hottest and coldest temperature differences ≥ 40 C)	2,40 mt * 2,40 mt	3,60 mt * 3,60 mt	13 mm

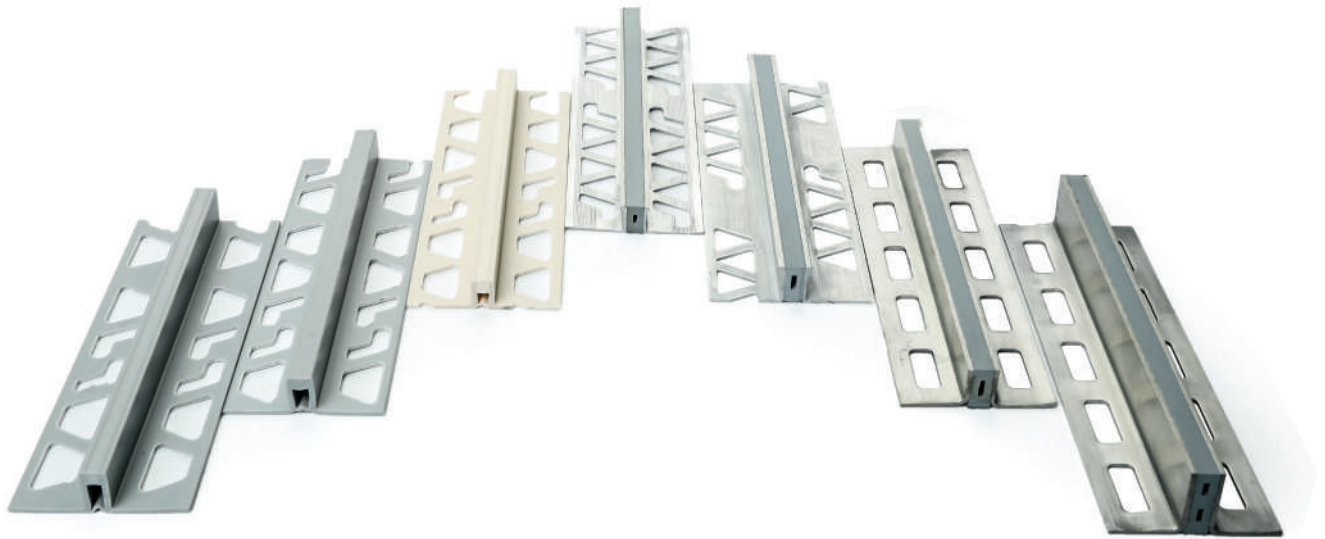

» DP 01-14

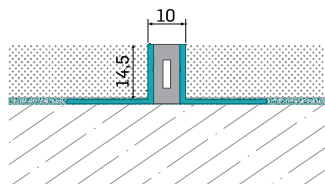

» DP 01-16

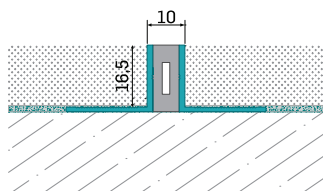

» DP 01-23

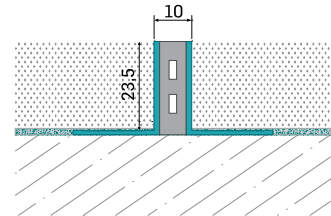

» DP 01-25

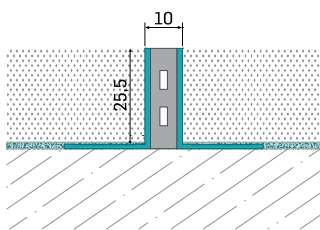

» DP 01-60

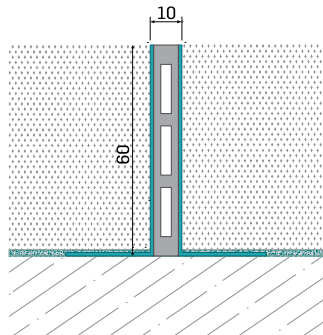

» DP 13-14

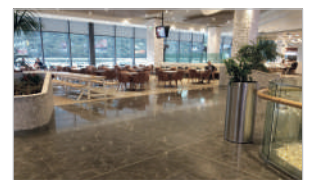
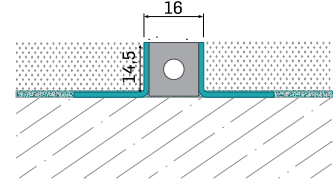

MOVEMENT
JOINT PROFILES

PRODUCT CODE	VISIBLE SURFACE (b) mm	PROFILE HEIGHT (h) mm	LOAD CAPACITY mm
DP 01-06	10	6,5+1,2	+5/-3
DP 01-08	10	8,5+1,2	+5/-3
DP 01-10	10	10,5+1,2	+5/-3
DP 01-12	10	12,5+1,2	+5/-3
DP 01-14	10	14,5+1,2	+5/-3
DP 01-16	10	16,5+1,2	+5/-3
DP 01-23	10	23,5+1,2	+5/-3
DP 01-25	10	25,5+1,2	+5/-3
DP 01-60	10	58,5+1,5	+5/-3
DP 13-14	16	14,5+1,5	±7

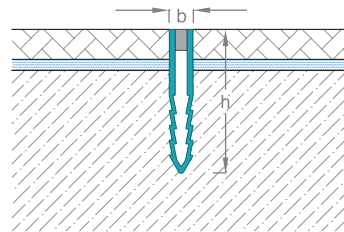
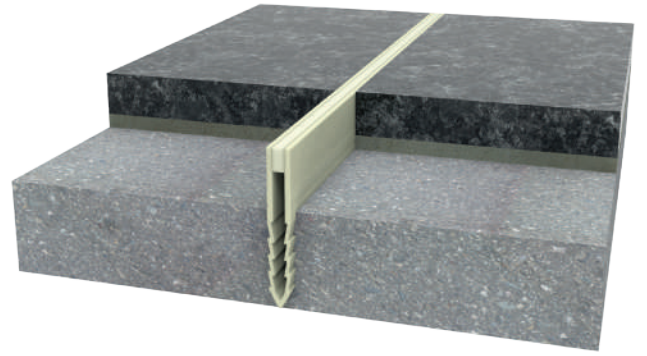
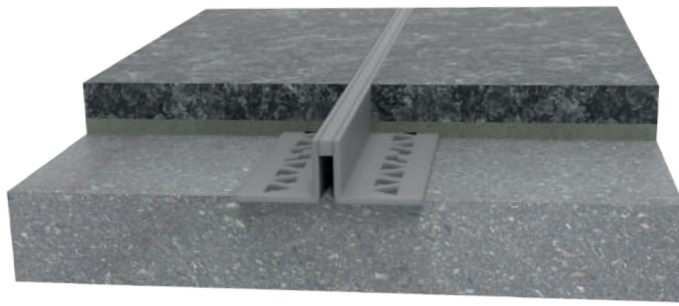

» DP 02-10

» DP 02-12

» DP 02-15

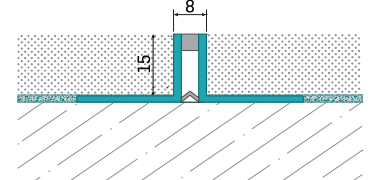
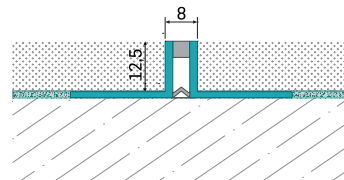
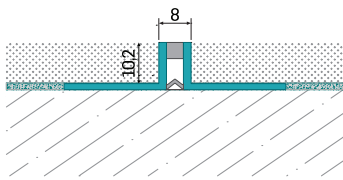

» DP 06

» DP 06-1

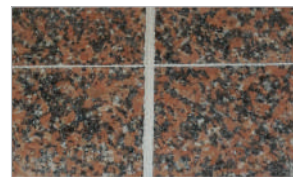
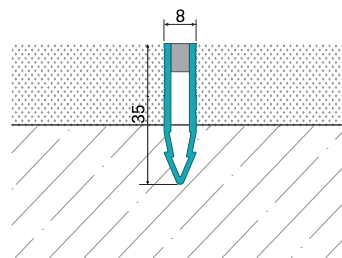
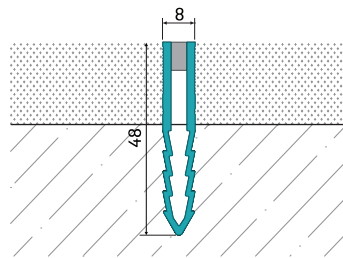

PRODUCT CODE	VISIBLE SURFACE (b) mm	PROFILE HEIGHT (h) mm	LOAD CAPACITY mm
DP 02-10	8	10,5+1,2	±2
DP 02-12	8	12,5+1,2	±2
DP 02-15	8	15+1,2	±2
DP 06	8	48	±2
DP 06-1	8	35	±2

Stainless Steel
304 Quality

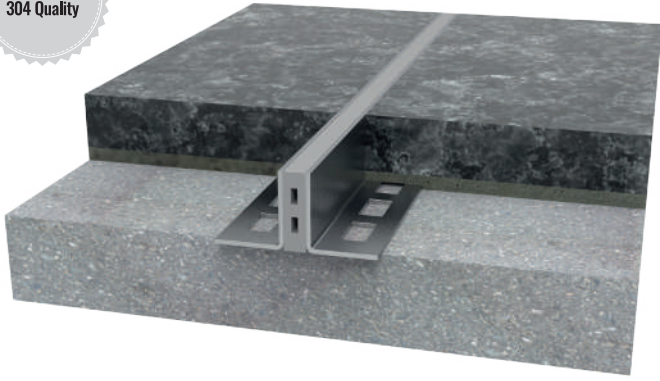

» DP 08-12

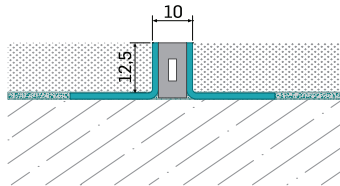

» DP 08-14

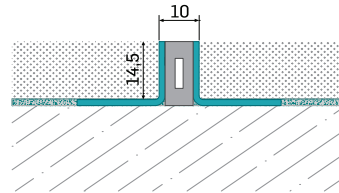

» DP 08-16

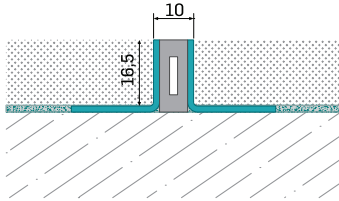

» DP 08-23

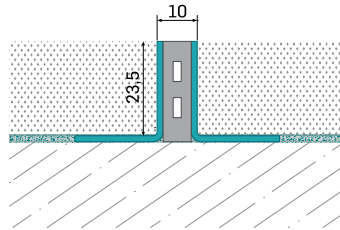

» DP 08-30

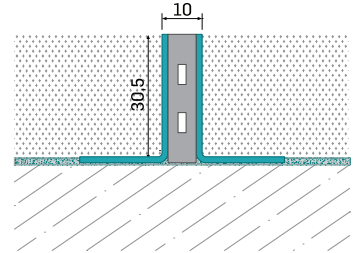

» DP 11

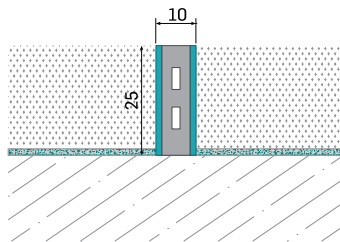

» DP 14-14

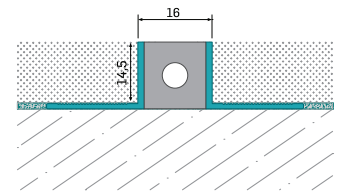

APPLICATIONS

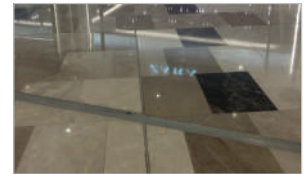

MOVEMENT
JOINT PROFILES

PRODUCT CODE	VISIBLE SURFACE (b) mm	PROFILE HEIGHT (h) mm	LOAD CAPACITY mm
DP 08-12	10	12,5+1,5	+5/-3
DP 08-14	10	14,5+1,5	+5/-3
DP 08-16	10	16,5+1,5	+5/-3
DP 08-23	10	23,5+1,5	+5/-3
DP 08-30	10	30,5+1,5	+5/-3
DP 11	10	25	+5/-3
DP 14-14	16	14,5+1,5	±7

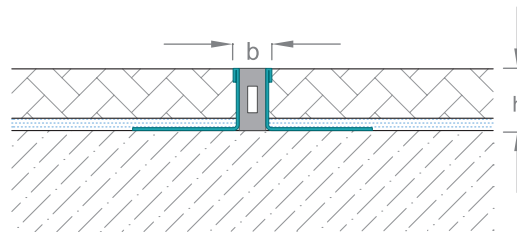
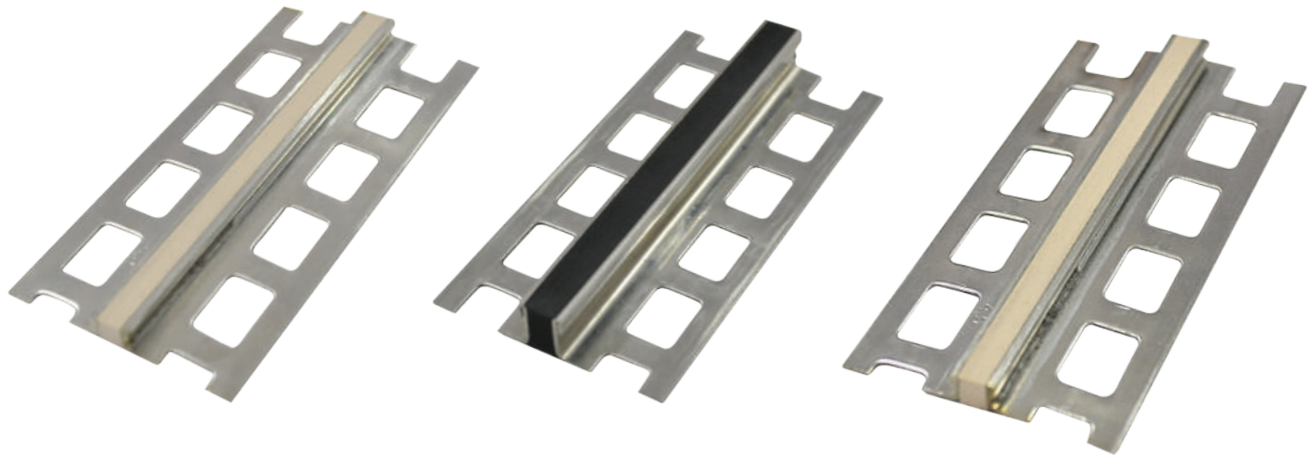

» DP 09-04

» DP 09-06

» DP 09-08

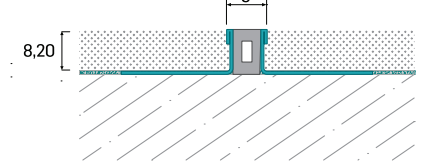
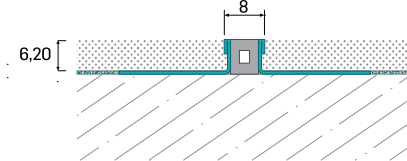
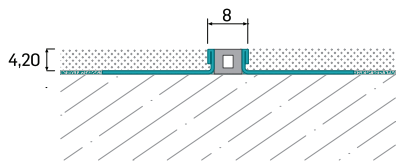

» DP 09-10

» DP 09-12

» DP 09-20

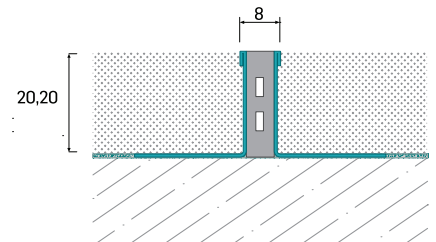
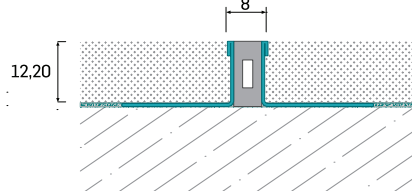
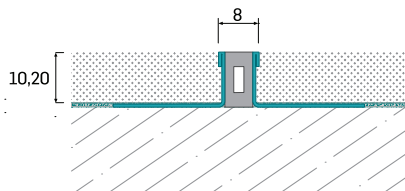

APPLICATIONS

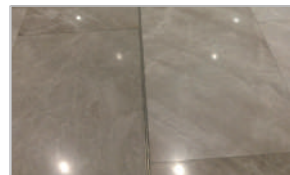
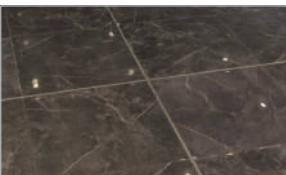

PRODUCT CODE	VISIBLE SURFACE (b) mm	PROFILE HEIGHT (h) mm	LOAD CAPACITY mm
DP 09-04	8	4,20+0,8	+5/-3
DP 09-06	8	6,20+0,8	+5/-3
DP 09-08	8	8,20+0,8	+5/-3
DP 09-10	8	10,20+0,8	+5/-3
DP 09-12	8	12,20+0,8	+5/-3
DP 09-20	8	20,20+0,8	+5/-3



insulation pressure profiles and coping systems

COPPING PROFILES

Anodised or powder coated finishing products that compatible with various exterior cladding materials, terrace parapet applications and assembled through 2 mm or 3 mm carrier pieces.

» ARH-20

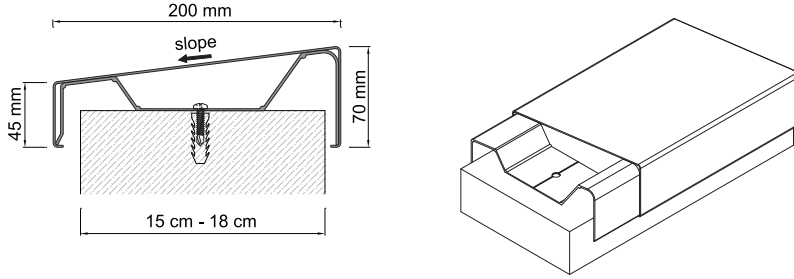

Extruded profiles. One lower carrier piece screwed on the parapet every 50 cm interval. H-section profile or TPE joint seals are installed on the joints

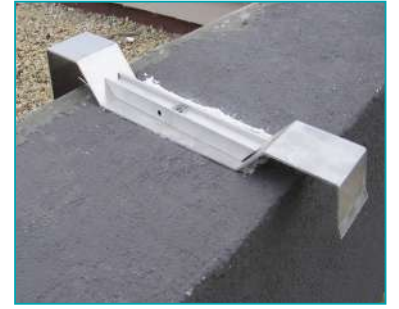

» ARH-22

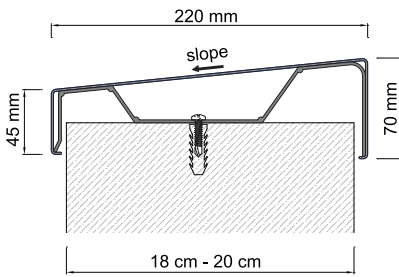

» H BİRLEŞİM FİTİLİ

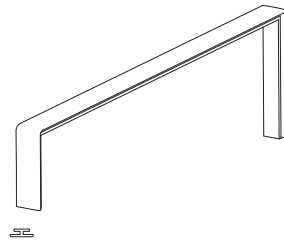

Extruded profiles. Product lengths can be produced up to 6 mt in single piece.

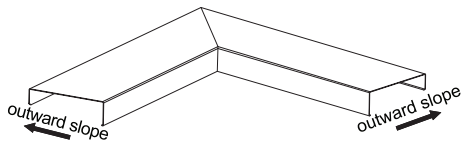

» Internal Corner Detail

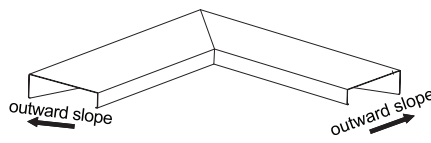

» External Corner Detail



» ARH-25

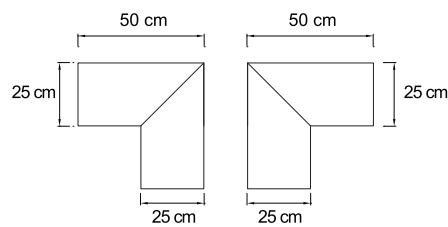
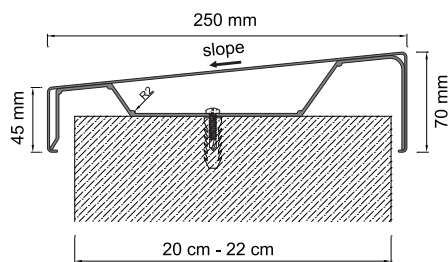

» External Corner Detail

» Internal Corner Detail

Extruded profiles. Lower carrier piece shipped by 7 cm cutted.





» ARH-30

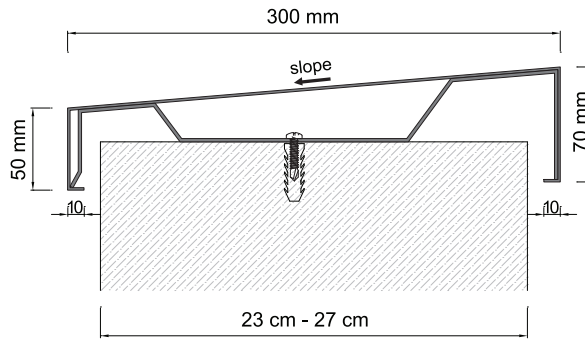

Produced of 1,5 mm aluminum sheet. Carrier pieces produced of 2,00 mm thick hard alloy plate. Production length is 3,00 mt.



» ARH-35

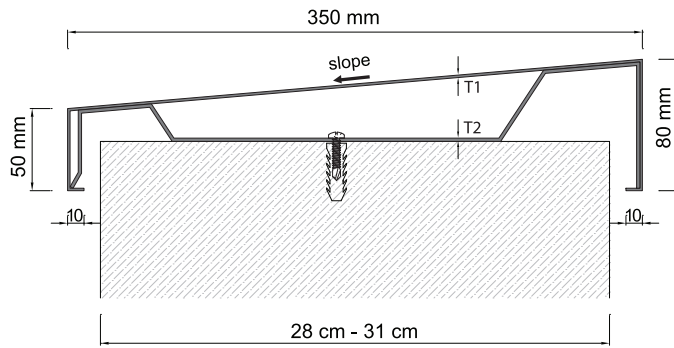

Top width \leq 350 mm if T1=1,5 mm T2=2 mm
 Top width $>$ 350 mm if T1=2 mm T2=3 mm



» ARH-40

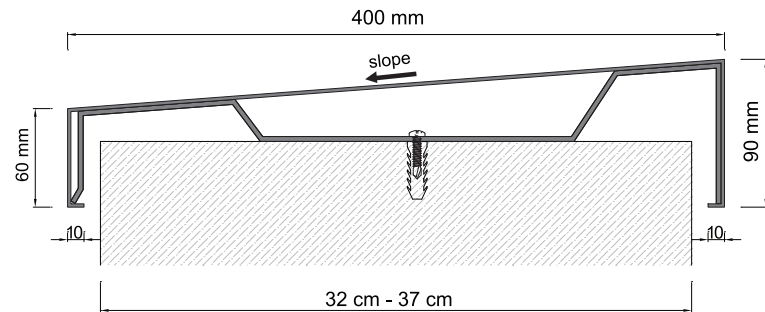

Carrier pieces produced of 3,00 mm thick and coping profiles 2,00mm hard alloy plate.



BALCONY, TERRACE AND PARAPET DRIP PROFILE

Dropper profiles can be applied with all kinds of finishing elements such as ceramic, granite and etc. and applications where open terrace and balconies do not require parapet in applications. In bituminous membrane applications, dropper profiles can be used as a final layer of the top layer slated membrane.

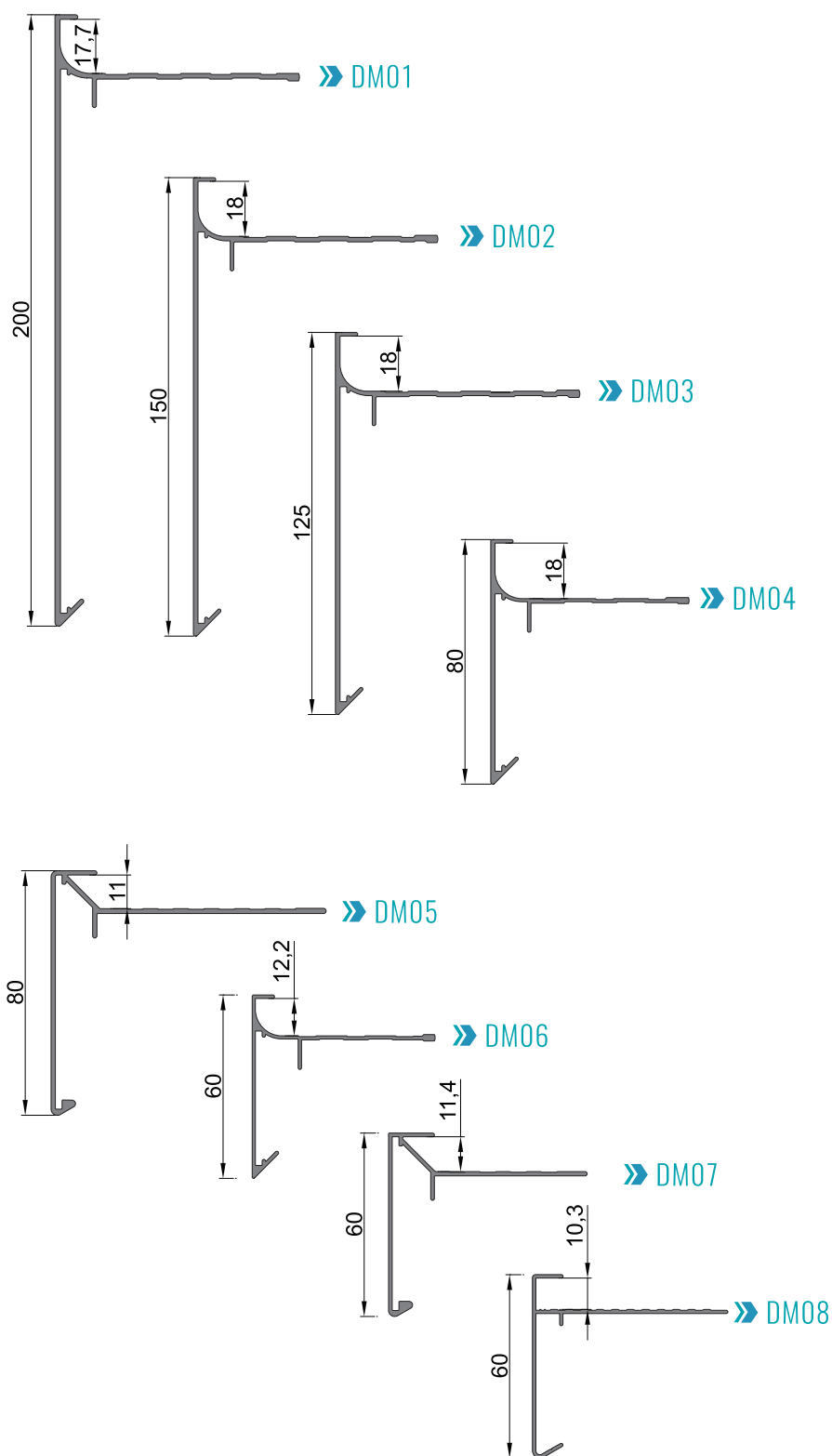



» SLATED MEMBRANE PARAPET FINISHING DETAIL

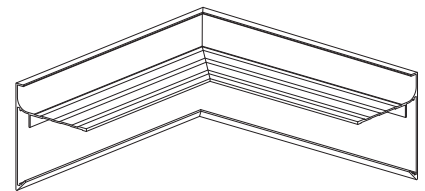
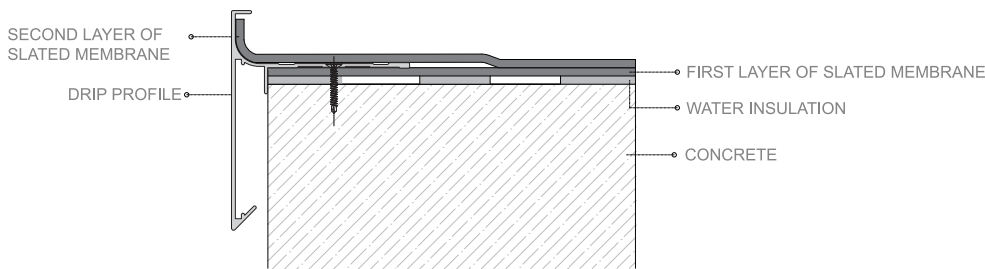

» PARAPET DRIP CORNER DETAIL

» COPPING FINISHING DETAIL

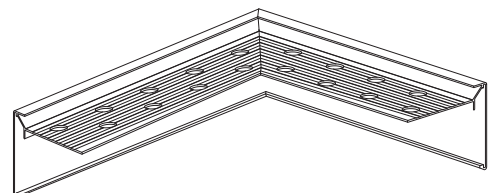
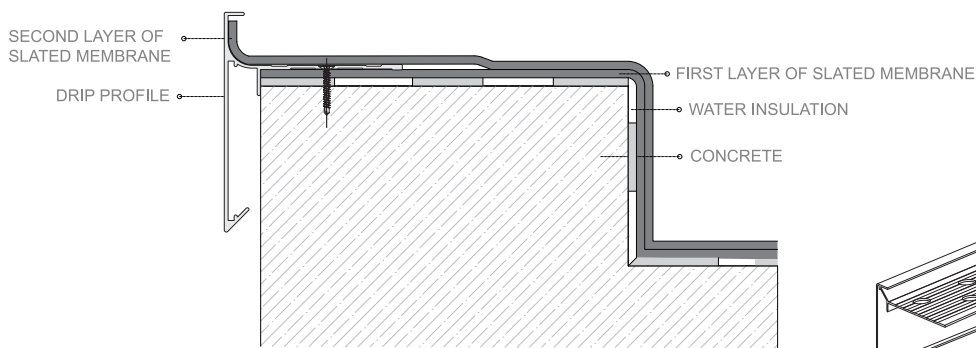

» CONCRETE&TERRACE DRIP CORNER DETAIL

» CERAMIC FINISH BALCONY-TERRACE DETAIL

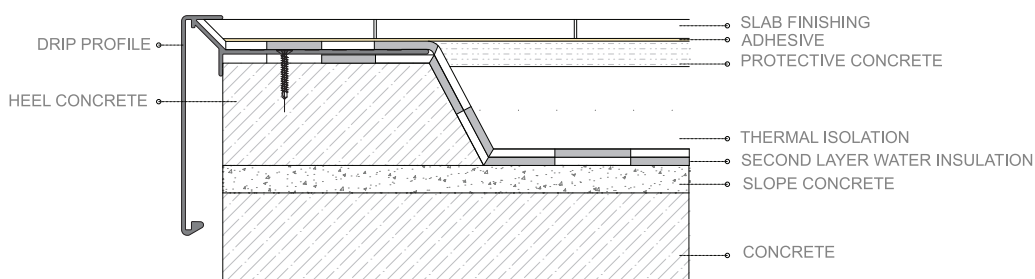

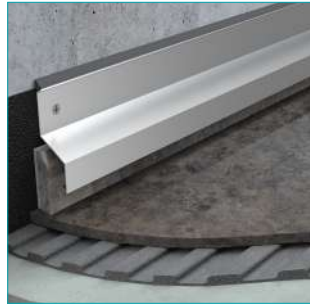

ALUMINIUM INSULATION PRESSURE PROFILES

Aluminum Insulation Pressure Profiles are compatible with all kinds of bitumen, PVC, TPO, TPE membrane applications at the end of the insulation details. Surface mounted, recessed models as well as wide flashing types are available.

» AR2001

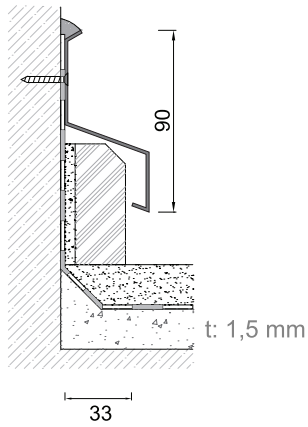

» AR2002

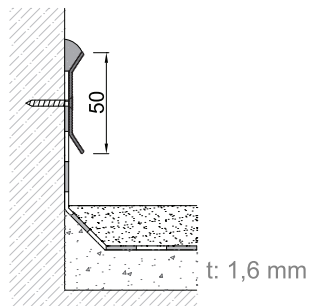

» AR2003

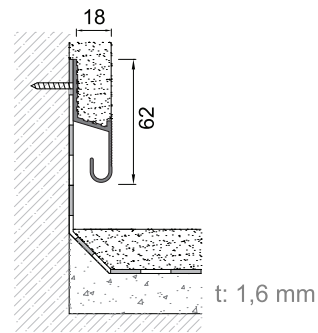

» AR2004

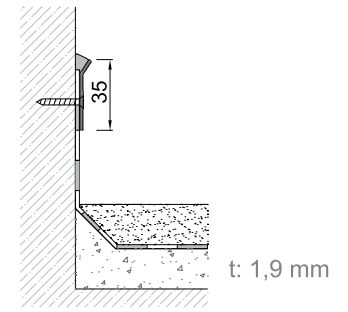

» AR2006

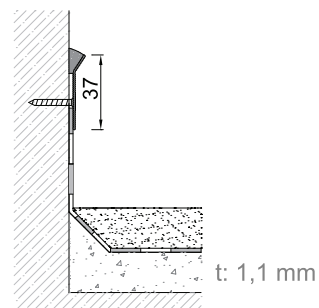

» AR2005

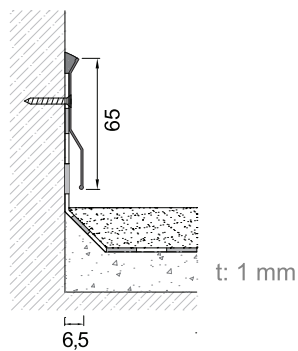

» AR2008

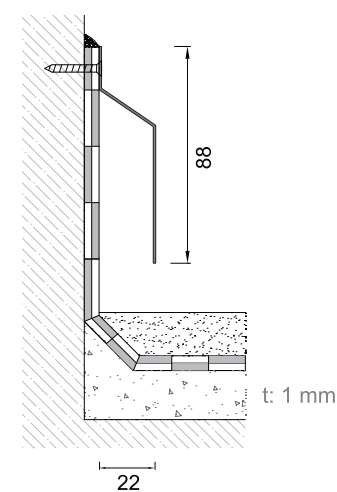

» AR2007

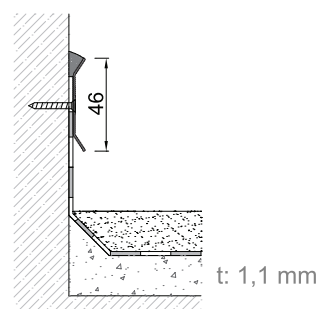

» AR2009

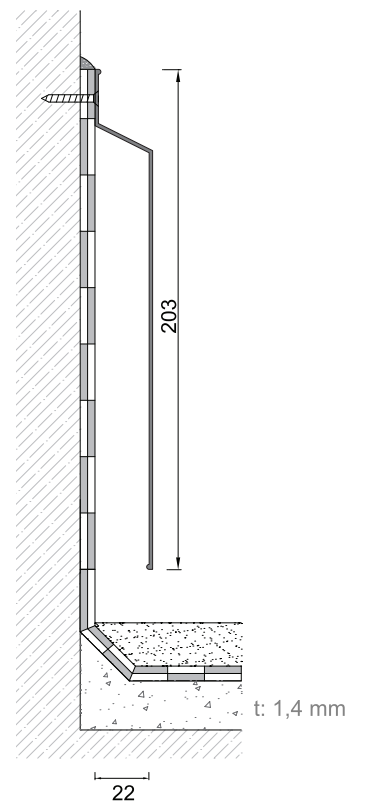

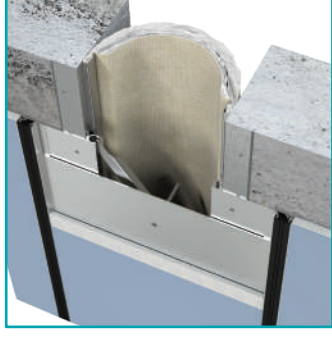
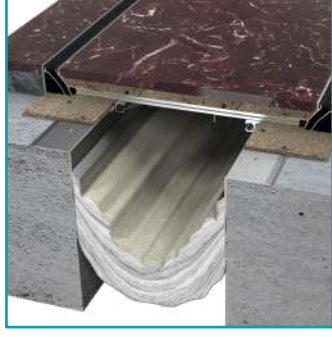
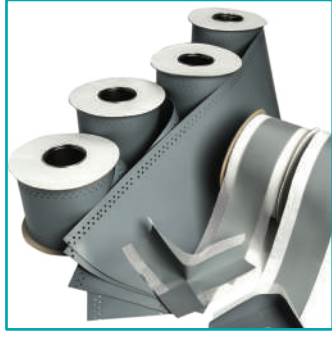
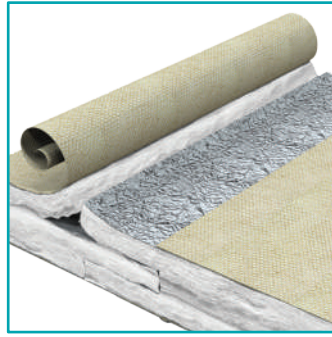

fire and water barriers



ARFEN FIRE BLANKET (HORIZONTAL)

Firestop 120 is a high performance, low weight, 7 layer fiberglass fire blanket that is designed to prevent fire and smoke passage in Expansion Joint gaps and also prevents heat transfer and flame transition to cold side. ARFEN fire barriers can be applied easier and faster than traditional solutions. ARFEN fire barriers have designed and tested to resist fire longest when mounted properly.

Can be used in vertical and horizontal gaps from 100 mm to 300 mm. Suitable for floor applications.

Application areas: Carparks, hospitals, shopping centres, schools, library and etc.

- Horizontal Fire Resistance Time : EI180 (EN 1366-4:2006+A1:2010)
- Fire Resistance Classification: A1
- Product Sizes: 100- 300 MM
- Vertical Use Suitability: NO
- Horizontal Use Suitability: YES

E 180 – EI 60 – H – M50 – B- W100-450 MM

Reference	Initial Gap (mm)	Maximum Gap (mm)	Min. Gap (mm)	Classification
FS100	100	150	40	E180 - EI60 - H - M50 - W100
				E120 - EI20 - V - M50 - W100
FS150	150	225	40	E180 - EI60 - H - M50 - W100
				E120 - EI20 - V - M50 - W100
FS200	200	300	40	E180 - EI60 - H - M50 - W100
				E120 - EI20 - V - M50 - W100
FS250	250	375	40	E180 - EI60 - H - M50 - W100
				E120 - EI20 - V - M50 - W100
FS300	300	450	40	E180 - EI60 - H - M50 - W100
				E120 - EI20 - V - M50 - W100



Fire Blanket Layers

60 MINUTES ISOLATION **180** MINUTES OF INTEGRITY

ARFEN FIRE BLANKET APPLICATION

1st Step

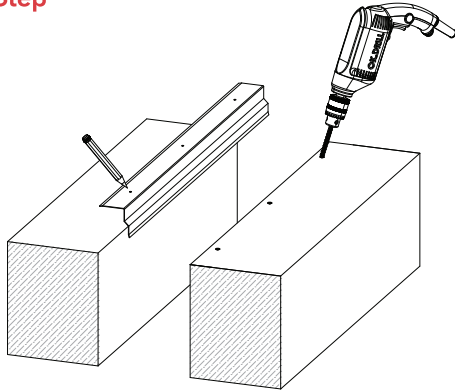

1st Step: The concrete surface and expansion joint gap should be cleaned. The galvanized moutage profiles should be placed on the concrete surface and concrete should be marked through holes on the galvanized profiles, after that fixation holes should be opened with 6,5 mm drill. The holes started from beginning point 150 mm and continue with the interval of 300 mm

2nd Step

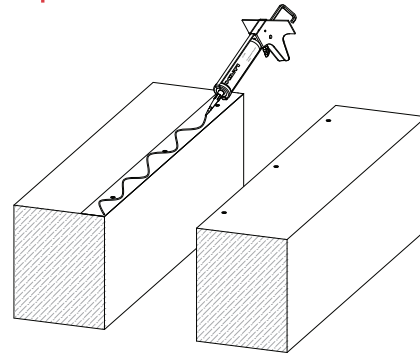

2nd Step: Sealant should be applied on the concrete surface and the layer should be 70 mm

3rd Step

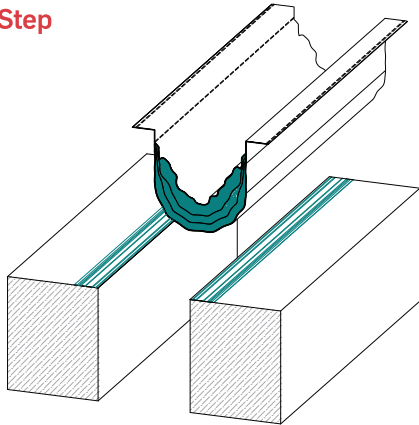

3rd Step: Fire barrier should be placed on the sealant layer. Wait for a while to get efficient bonding with sealant and barrier. After this process, fire barrier could be fixed with nails on the surface optionally

4th Step

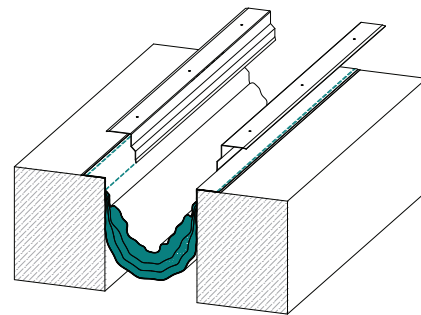

4th Step: Galvanized moutage profiles should be placed on the fire barrier which is already bonded with concrete surface.

5th Step

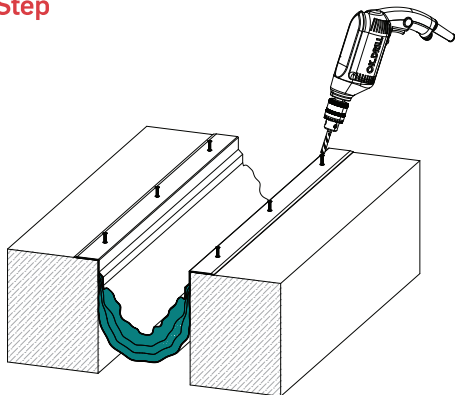

5th Step: Application should be done by E 8,0x80 Buldex Screw through the opened holes on galvanized moutage profiles.

6th Step

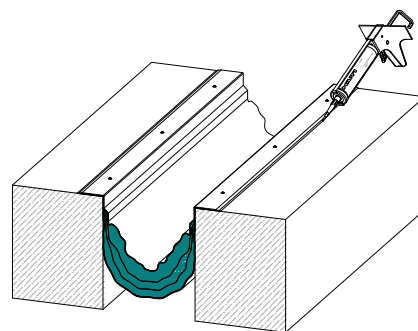

6th Step: The application will be completed with sealant to prevent any leakage between galvanized moutage profiles and concrete surface.

ARFEN FIRE BLANKET (VERTICAL)

Firestop 120 is a high performance, low weight, 7 layer fiberglass fire blanket that is designed to prevent fire and smoke passage in Expansion Joint gaps and also prevents heat transfer and flame transition to cold side. ARFEN fire barriers can be applied easier and faster than traditional solutions. ARFEN fire barriers have designed and tested to resist fire longest when mounted properly. Can be used in vertical and horizontal gaps from 100 mm to 300 mm. Suitable for floor and wall applications. Application areas: Carparks, hospitals, shopping centres, schools, library and etc.

- Vertical Fire Resistance Time: EI120 (EN 13501-2:2016)
- Fire Resistance Classification: EN1366-4:2006 + A1:2010
- Product Sizes: 100- 300 mm
- Vertical Use Suitability: Yes
- Horizontal Use Suitability: No

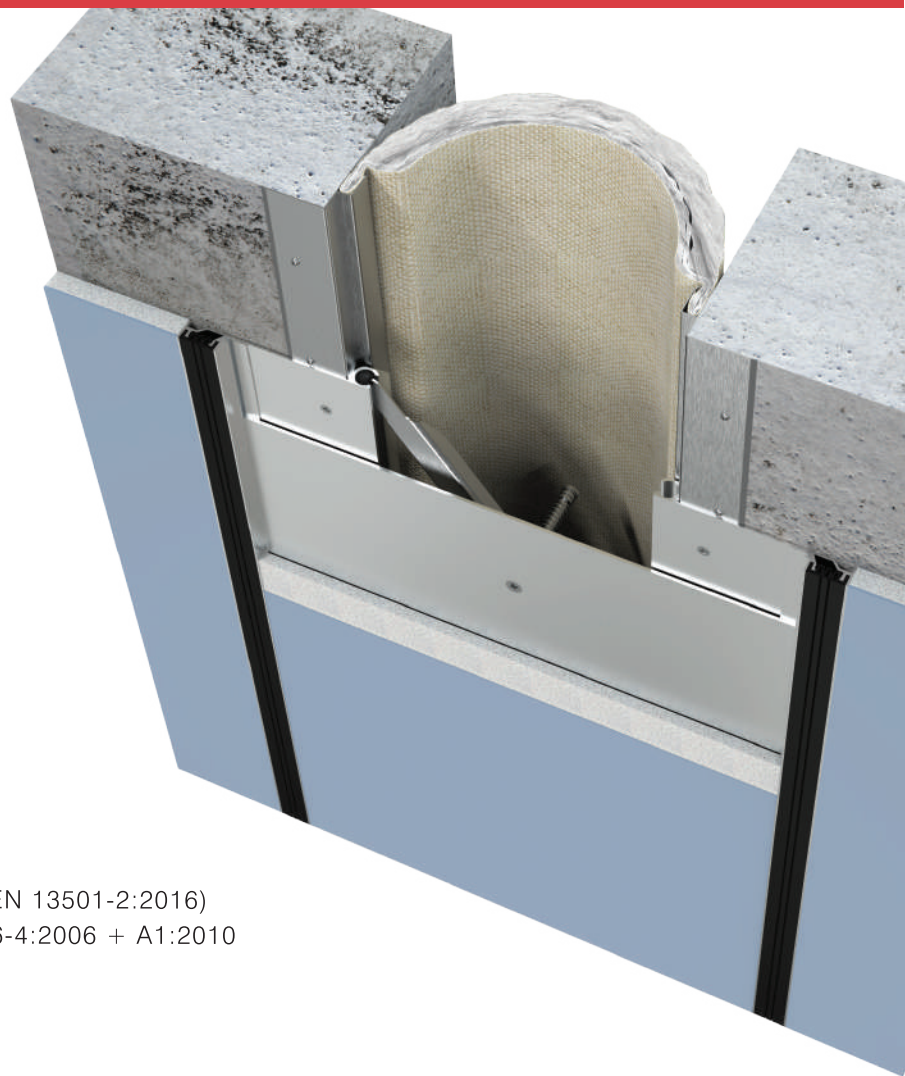

EI20 –EI 20- V- M050 – F – W 100 MM – 300 MM

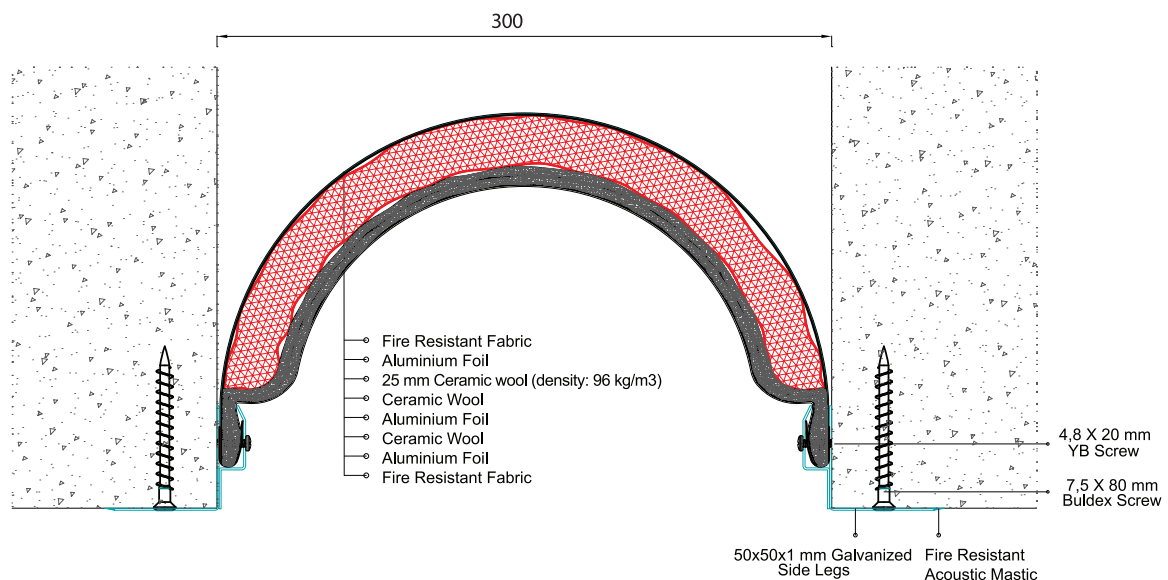

20 MINUTES ISOLATION **120** MINUTES OF INTEGRITY

ARFEN FIRE BLANKET APPLICATION

1st Step

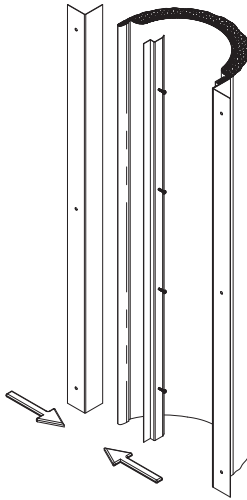

1st Step: The Vertical Fire Barrier detail which is 7 mt long prepared and assemble with galvanized mountage profiles in ARFEN facility and dispatch to the site

2nd Step

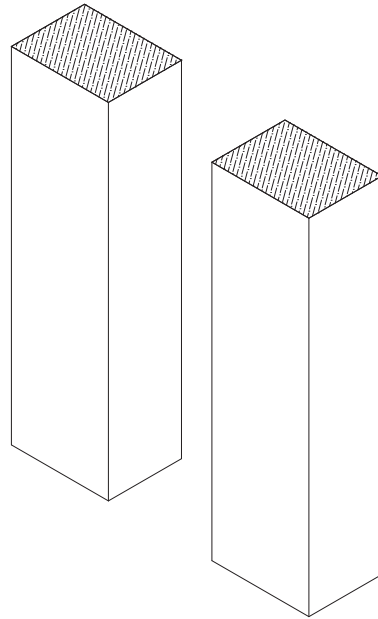

2nd Step: Concrete surface should be cleaned and should be prepared to application

3rd Step

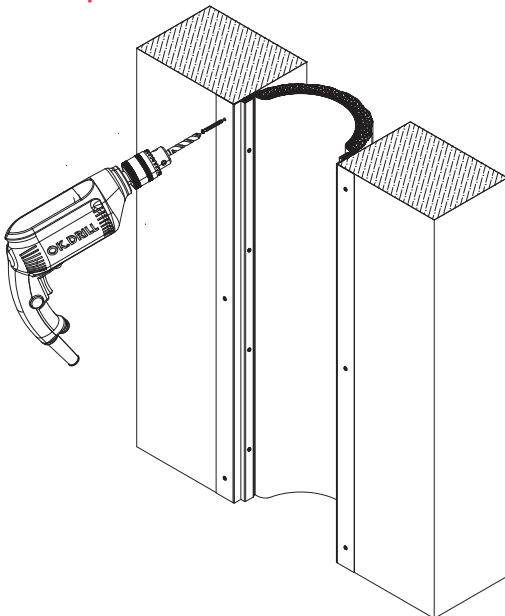

3rd Step: The Vertical Fire Barrier should be placed on the wall and immobilized with 7,5 x 80 mm buldex screw.

4th Step

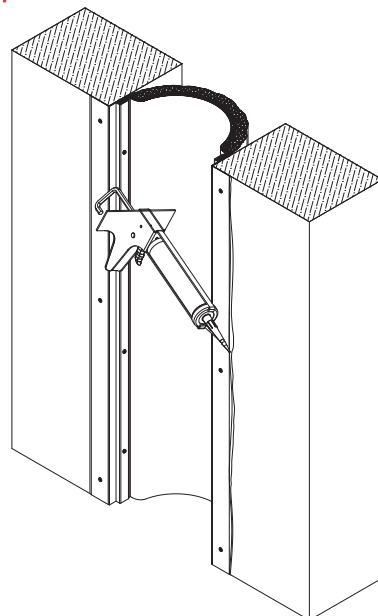

4th Step: The application will be completed with Fire resistant sealant to prevent any leakage between galvanized mountage profiles and concrete surface

ARFEN **ROCK WOOL FIRE ROPE**

Arfen fire insulation rope can be easily applied because of type used as Glass yarn weaving on rock wool. Should be placed in the expansion joint gap by compression of at least 33%

Arfen fire insulation rope diameter to be selected according to the application area,

- Horizontal - Vertical Fire Resistance Time: EI240 (SIST EN 13501-2)
- Fire Resistance Classification: A1
- Product Sizes: 20 - 180 mm
- Product Density: 240 +/-20 Kg / m³
- Horizontal And Vertical Use Suitability: Yes
- ETA 17/0061

EI240 – H – X – F – W 10 MM – 150 MM

Expansion Joint Gap Dimension (mm)	<10	11-15	16-20	21-30	31-40	41-50	51-60	61-70	71-80	81-90	91-100	101-110	111-120	121-130	131-140	141-150
Material Diameter to be applied (mm)	20	25	30	40	50	60	70	80	90	100	120	130	140	150	160	170

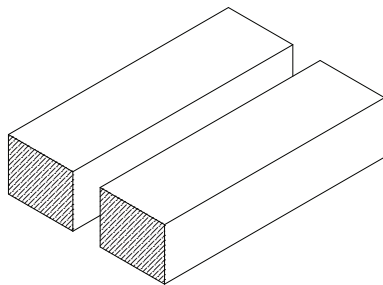

1st step
Concrete surface area and expansion joint gap should be cleaned and prepared to be suitable for application

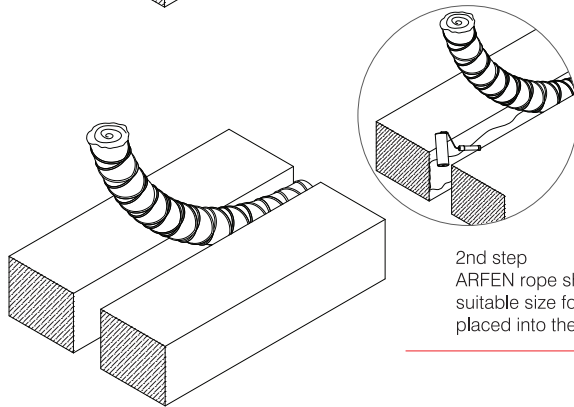

2nd step
ARFEN rope should be selected according to suitable size for the expansion joint gap and placed into the gap with squeeze

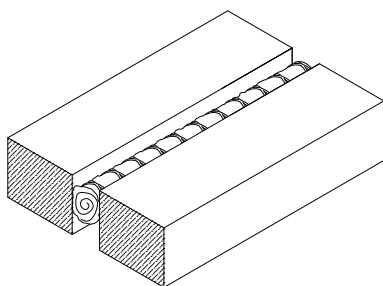

3rd step
If required, the rope can be fixed with suitable sealant or adhesive on the edge of concrete surface

ARFEN FIRE MULTICOATED FIRE STOPPING GAP FILLER

This product is multicoated water based acrylic fire stopping gap filler. Applied on rock wool by a roll or spray internally or externally. ARFEN's fire stopping gap filler has 25% movement capacity of the gap applied in and can resist to fire up to 2 hours.

- Produced in buckets of 5 litre and 15 litre
- Density 1.35 kg/dm³
- Ideal storage temperature: 5.30 C, minimum shelf life is 1 year
- Application Temperature: 5.30 C
- Drying Time: 2-4 hours
- Recommended thickness: Wet sheet thickness 2mm, Dry sheet thickness 1 mm.
- Usage: 1.4 Lt/m²
- Colour: White
- Waterproof. (Limited to 25% movement capacity)
- Note: Rockwool needs to be compressed 33% before fitting in to Expansion Joint Gap.

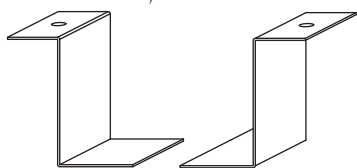
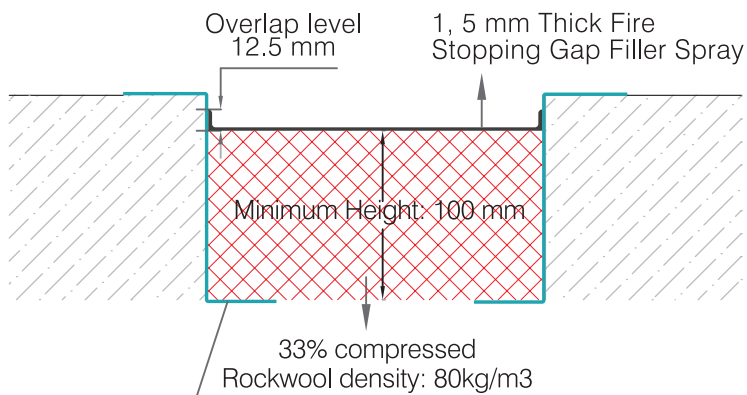

Galvanized bracket used in wide Expansion Joint gaps.

OPTIONAL

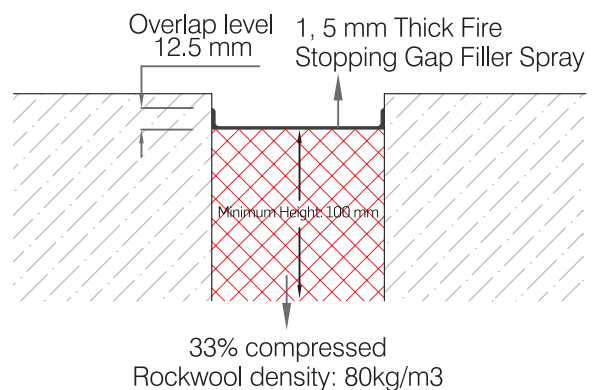



ARFEN **CONSUMABLES** **FIRE-RESISTANT ACOUSTIC MASTIC**

An acrylic based firestop sealant that provides movement capability in fire rated joints and seals through-penetrations applications

- Silicone free
- Halogen, asbestos and solvent free
- Paintable
- Tested up to %33 movement with 500 cycles in accordance to UL 2079 and ASTM 1966
- Smoke and fume resistant
- Easy clean up with water
- Single component systems available
- Meets LEED requirements for indoor environmental quality credit 4.1 Low Emitting Materials, Sealants and Adhesives and 4.2 Paints and Coatings



Technical Data	Acoustic Mastic
Chemical basis	Acrylic based firestop sealant
Color	Available in red, white and gray
Application temperature	40°F to 104°F (5°C to 40°C)
Skin-forming time	Approx 15 min
Curing time	Approx 3 mm / 3 days
Average volume shrinkage (ASTM C1241)	22.2%
Movement capability	Approx 10%
Temperature resistance	-22 F to 176 F (-30°C to 80°C)
Surface burning characteristics (ASTM E 84-96)	Flame Spread: 10 Smoke Development: 0
Sound transmission classification (ASTM E 90-99)	56 (Relates to specific construction)

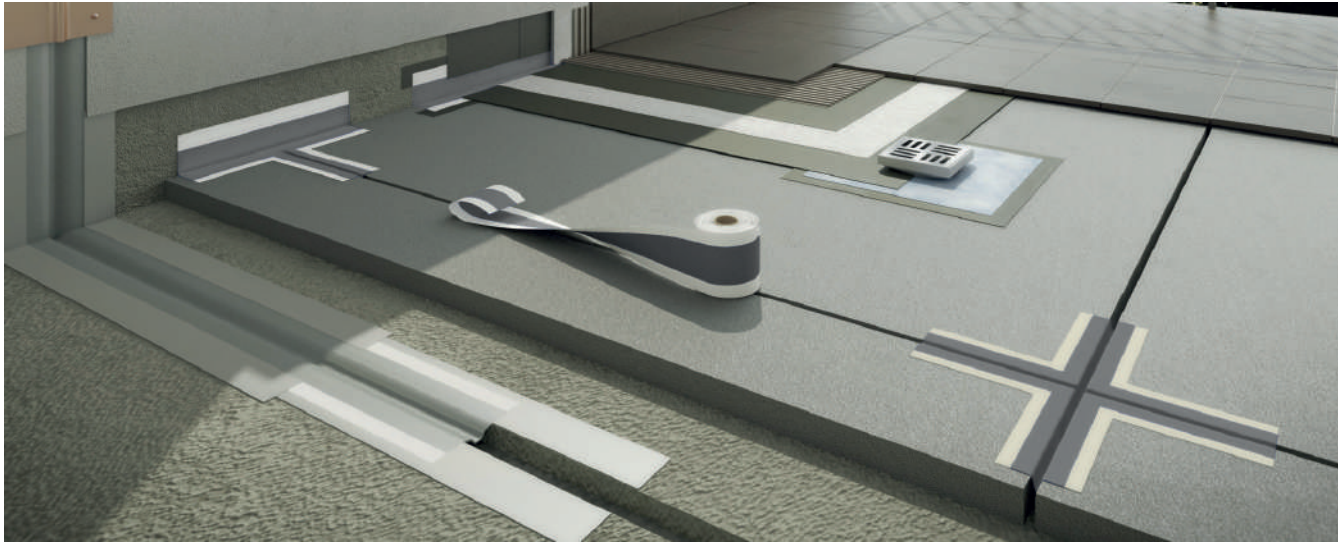

Highly elastic HYDROFLEX expansion joint tape is used for every type of buildings in isolating expansion joint gaps, thermal gaps and cracks. Alternative options are available for without holes or with holes at 150 mm, 200 mm, 250 mm, 300 mm, 400 mm width and 1 mm, 1,5 mm thickness.

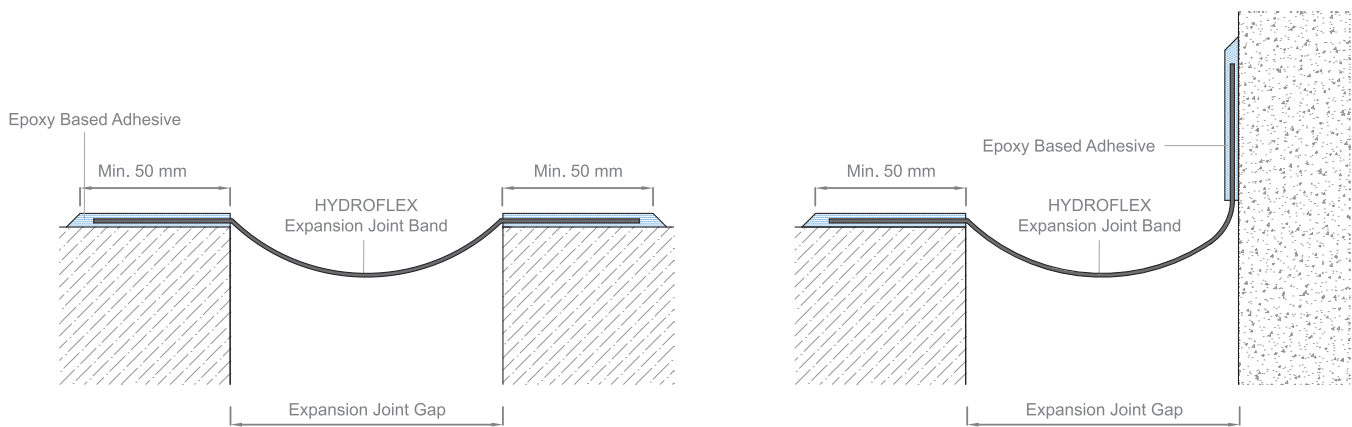

» SPECIFICATIONS AND ADVANTAGES

- Easy application with epoxy adhesive.
- Highly elastic characteristic (600%).
- Strong adhesion to concrete, steel and many other building materials.
- Resistant to plant roots.
- Uv and oil resistant.
- Good performance between wide temperature values.
- Easy to cut, weld (hot air) and joint.

» HYDROFLEX USAGE AREAS

- Horizontal and vertical application on all type of buildings
- Foundations and curtain walls.
- Waste water treatment plants, potable water plants, water tanks pools.
- Tunnels and concrete pipes and boxes.
- Between foundation and curtain wall connection lines.

HYDROFLEX TECHNICAL SPECIFICATIONS

Chemical composition	TPE (Thermoplastic Elastomer)
Colour	Grey
Hardness level	80
Serving temperature value	-40 °C / +90 °C
Thermal Temperature value	270 °C
Elongation at break	%600
Tear strength	> 600N/cm
Water Pressure resistant value	> 8 Bar
Tensile strength	> 6 Mpa
UV resistance value	> 7500 h
Bitumen resistance	Good
Sulfuric acid resistance	Good
Alcohol resistance	Good
Detergent resistance	Good

PRODUCT CODE	WIDTH	THICKNESS	LENGTH
HYDROFLEX 150	150	1 mm & 1,5 mm	25 mt / rulo
HYDROFLEX 200	200	1 mm & 1,5 mm	25 mt / rulo
HYDROFLEX 250	250	1 mm & 1,5 mm	25 mt / rulo
HYDROFLEX 300	300	1 mm & 1,5 mm	25 mt / rulo
HYDROFLEX 400	400	1 mm & 1,5 mm	25 mt / rulo

APPLICATION STEPS

1ST STEP



2ND STEP

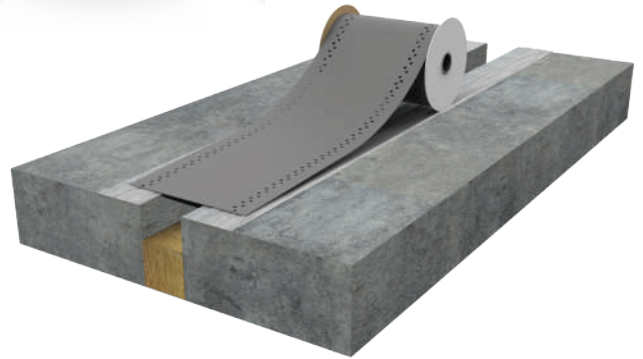

3RD STEP

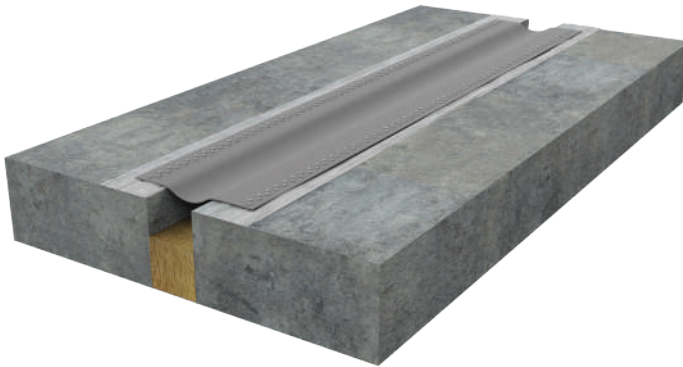

4TH STEP



» APPLICATION AREA

Bonding of expansion joint tape anchoring the rods and bars to the concrete, stone or brick.
Repair and isolating of wide cracks

» SPECIFICATION AND ADVANTAGES

Perfect adhesion to the concrete and steel. Resistant to chemicals
Solvent free, It can be applied all types of expansion joint gap,
Water and gas impermeable, Perfect adhesion to the damp surfaces on concrete,
Easy to apply, It doesn't need any primer before application.

HYDROFLEX 21 is a composition of 2 epoxy based material. Used for fixing, anchoring and sticking purposes.



TECHNICAL SPECIFICATIONS OF EPOXY BASED DILATATION ADHESIVE

Number of components	2 Components A and B
Chemical Specifications	A Component: Epoxy Resin B Component: Epoxy Hardener
Mixed Rate - Weight A/B	3,75 kg / 1,25 kg
Mixed Density	1,7 kg / lt
Fully Cured	Pedestrian usage 24 hours Fully Cured and Open Service : 7 days
Pot Life	40 dk (20 C)
Curing Time	Recoatible after : 8-10 hours Fully Cured : 7 days



ARFEN CHAMPER & CRACK TAPE

HYDROFLEX 120 is used for isolation of critical point on wet area corners and isolating required areas. HYDROFLEX 120 is suitable with many kind of materials.

- ✓ It doesn't need any extra adhesive usage as it is compatible with any kind of isolation materials
- ✓ Easy installation
- ✓ High elasticity capacity
- ✓ %100 water proof
- ✓ Resistant to many kind or chemicals
- ✓ Good resistant to Ozone and UV
- ✓ High performance for wide temperature range (-40 ,+90 °C).

Note: Our new felt version band is also available under HYDROFLEX 121 product code.



SODIUM BENTONITE BASED WATER SWELLING BAND

ARFEN's water swelling band designed to fill gaps or crack in concrete by swelling in contact with water.

- ✓ Easy to apply.
- ✓ Easy application even with huge amount of rebar.
- ✓ Placing in right position and pressing are only the steps for mounting to connection areas.
- ✓ Safely swelling feature does not allow it to get swollen in pouring concrete cases.
- ✓ Can be used in drinking water as it doesn't get mixed with water.
- ✓ Can be used in Swimming pools, tunnels, subways, retaining walls, curtain walls.
- ✓ Can be used in Water tanks, sewage systems, and water purification facilities.
- ✓ Concrete joints, dams, road and intersections of old and new concretes.



ACRYLIC BASED WATER SWELLING BAND

Acrylic based water stop band gets swollen when in contact with water. Application areas are: swimming pools, water tanks, sewage plants, and construction joints. Also applicable in cold joints where curtains are connected with foundations, and steel profile and pipe's contact areas with concrete. It can be used to provide seals in areas exposed to sea water as well.

- ✓ Easy to apply.
- ✓ Can be used in various surfaces
- ✓ Easy application even with huge amount of rebar.
- ✓ Safely swelling feature does not allow it to get swollen in pouring concrete cases.
- ✓ Fills possible gaps and cracks by swelling and acts as a water barrier in the reinforced concrete structure.
- ✓ Resistant to highly salted water content and various chemicals.

REFERENCES

EUROPE & NORTH ASIA

QEBELE CONVENTION CENTER, AZERBAIJAN
SHAHDAG TOURISM COMPOUND, AZERBAIJAN
AXIS TOWER – TBILISI / GEORGIA
ORBI GROUP – BATUM ORBI CITY
DEKON TAAH. – BATUM LE MERIDIEN OTEL
ÇALIK HOLDİNG – TURKMENISTAN BURN TREATMENT CENTER
SUMMA İNŞAAT – NIGER MINISTRY OF FINANCE
SUMMA İNŞAAT – MOLDOVA ARENA
SUMMA İNŞAAT – NIGER AIRPORT
PALVAN İNŞAAT – UZBEKISTAN TASHKENT CITY
GEMİKAYA HOLDİNG – NAHCHIVAN / AZERBAIJAN PROJECTS
OLD BAKU CONSTRUCTION – BAKU IBIS OTEL
NORTH WEST CONSTRUCTION – BAKU WATER FRONT MALL

NORTH AFRICA

SHARM EL SHEIKH INTERNATIONAL AIRPORT, EGYPT
HURGADA INTERNATIONAL AIRPORT, EGYPT
BURJ AL ARAB AIRPORT, EGYPT
HSBC OFFICE BUILDING, EGYPT
CIB OFFICE BUILDING-SMART VILLAGE, EGYPT
SAUDI ARABIA NEW EMBASSY BUILDINGS, DUBAI
FOUR SEASONS HOTEL IN CAIRO, EGYPT
FOUR SEASONS HOTEL IN SHARM EL SHEIKH, EGYPT
SAN STEFANO HOTEL IN ALEXANDRIA, EGYPT
BANEASA SHOPPING MALL, ROMANIA
JUMBO SHOPS, ROMANIA
NERVOLOGICAL HOSPITAL, ROMANIA
KRASNODAR REGIONAL HOSPITAL, RUSSIA
BELOYARSK HOSPITAL, RUSSIA
VOLKSWAGEN FACTORY / SAMARA, RUSSIA
BAKU FLAME TOWERS, AZERBAIJAN
BAKU TRUMP TOWER AZERBAIJAN

MIDDLE EAST

STAR HOTEL, DUBAI
MERCEDES-BENZ SERVICE CENTER, DUBAI
G+4+R LABOUR ACCOMMODATION, DUBAI
ADNOC MUBADALA SCHOOL, ABU DHABI
DRAGON MALL EXTENSION, DUBAI
HOTEL ROUNDABOUT, DUBAI
MBR MULBERRY HILLS, DUBAI
ABRAJ QUARTIER, QATAR
EXPO 2020 DEVELOPMENT PROJECT, DUBAI

NORTH AFRICA

SMART VILLAGE OFFICE BUILDINGS, EGYPT
HOLIDAY INN CAIRO, EGYPT
INTER CONTINENTAL CAIRO, EGYPT
UPTOWN PROJECT – EMAAR, EGYPT
LNG PROJECT - DAMIETTA PORT, EGYPT
CARREFOUR PROJECT-MAADI CITY CENTRE, EGYPT
CARREFOUR PROJECT-ALEXANDRIA CITY CENTRE, EGYPT
CARREFOUR PROJECT-DANDY MALL, EGYPT
VODAFONE PROJECT-SMART VILLAGE, EGYPT
LOCAL MOSQUE-SMART VILLAGE, EGYPT
CALL CENTRE PROJECT-SMART VILLAGE, EGYPT
MICROSOT BUILDING-SMART VILLAGE, EGYPT
PYRAMIDS HEIGHTS OFFICE BUILDINGS, EGYPT
EL REHAB CITY MALL, EGYPT
GREEN PLAZA COMPOUND-SHARM EL SHEIKH, EGYPT
CIB - CREDIT AGRICOLE - HSBC BANK BRANCHES, EGYPT
MADINATI SPORTS & SOCIAL CLUB, EGYPT
EUROPE & NORTH ASIA
TALLAGHT UNIVERSITY HOSPITAL, DUBLIN -IRELAND
LUKA KOPER- SLOVENIA
ERTELE MALL – HUNGARY
KOTKA HOSPITAL - FINLAND
PORTONOVİ RESORT AND VILLAGE - MONTENGRO
DOM POMOCY, POLAND
VITAL HOSPITAL, POLAND
SZPITAL UNİVERSİTESİ, POLAND
PLAZA MALL, ROMANIA
CARREFOUR PROJECTS, ROMANIA
MUNICIPAL HOSPITAL BUKRES, ROMANIA
ASGABAT AIRPORT, TURKMENISTAN
HEALTH COMPLEX SBUILDING, TURKMENISTAN
CARDIOLOGY HOSPITAL, TURKMENISTAN
WOMEN-MATERNITY HOSPITAL, TURKMENISTAN
MILITARY HOSPITAL, TURKMENISTAN
TRAUMATOLOGY HOSPITAL, TURKMENISTAN
DOM POMOCY, POLAND
VITAL HOSPITAL, POLAND
SZPITAL UNİVERSİTESİ, POLAND
PLAZA MALL, ROMANIA
CARREFOUR PROJECTS, ROMANIA
MUNICIPAL HOSPITAL BUKRES, ROMANIA

MIDDLE EAST

TENBEK HOSPITAL, QATAR
MALL of OMAN, OMAN
DUBAI METRO STATION & CAR PARK, DUBAI
PRIVATE & GOVERNMENT HOSPITALS, ABU DHABI
SHERATON HOTEL, DUBAI
SEA PORT PASSENGER TERMINAL, DUBAI
AJMAN TOWER AJMAN PALM JUMERIAH, DUBAI
MASDAR CAR PARK, ABU DHABI
ABU DHABI FINANCIAL CENTRE-SOWWAH SQUARE, ABU DHABI
LLH HOSPITAL, ABU DHABI
KINGS COLLEGE HOSPITAL, ABU DHABI
POWER STATION SADIYATH ISLAND, ABU DHABI
SOBHA HARTLAND SCHOOL, ABU DHABI
DRAGON MALL, DUBAI
AJMAN TOWER, DUBAI
KING ABDULLAH FINANCIAL DISTRICT, SAUDI ARABIA
SHARJAH CITY CENTRE, DUBAI
JVC CIRCLE MALL, DUBAI
TOWN SQUARE- ZAHRA APARTMENT, DUBAI
TOWN SQUARE- SAFI APARTMENT, DUBAI
TOWN SQUARE- HAYAT APARTMENT, DUBAI
TOWN SQUARE -HAYAT BOULEVARD, DUBAI
DEWA ACCOMODATION BUILDINGS, DUBAI
THE HILLS, DUBAI
HAMENI TOWER, DUBAI
AL MESSILA RESORT and VIP, QATAR
BAHRAIN INTERNATIONAL AIRPORT, BAHRAIN
KING SAUD UNIVERSITY, KSA

OTHERS

BASRA MUNICIPALITY HOSPITAL, IRAQ
HUMUS UNIVERSITY HOSPITAL, SYRIA
SANJHONS HOSPITAL, PALESTINE
MOSQUE AND COMMUNITY FACILITIE, ALGERIA
RES&COMM TOWER, DOHA QATAR
NOUAKSHOTT AIRPORT, MAURITANIA
NAZERBAYAV ÜNİVERSİTESİ, KAZAKHSTAN
DEBRECEN UNIVERSITY HOSPITAL, HUNGARY
HUALING OTEL, GEORGIA
LARA PARK OTEL, CYPRUS



SAMPLE OF APPLICATIONS

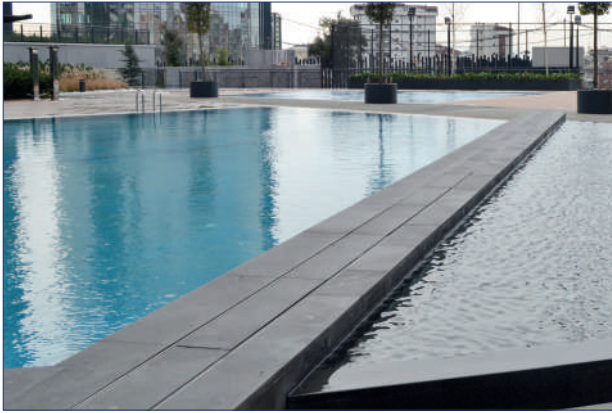

QUALITY CERTIFICATES



ZAG Fire Rope Test Certificate



Factory Production Control Certificate of Conformity



Efectis Fire Resistance Certificate



TSE Certificate



TSE Certificate

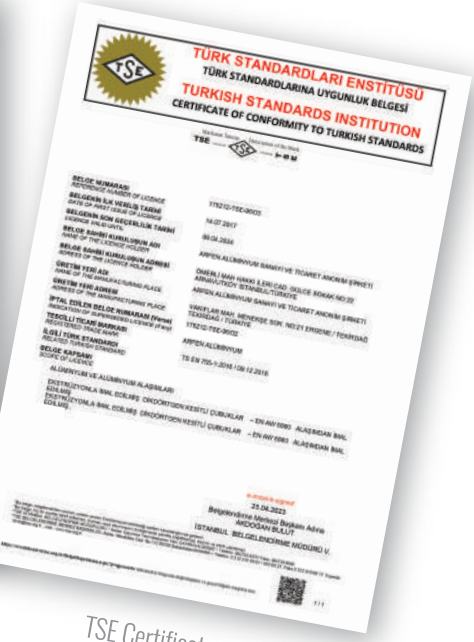

TSE Certificate



ISO 45001 Certificate



ISO 9001:2015 Certificate



ISO 14001:2015 Certificate



QUALICOAT SEASIDE Certificate



Factory Production Control Certificate



Brand Registration Certificate

we
build
solutions



ARFEN CONSTRUCTION MATERIALS COMPANY

Head Office: Atatürk San. Bölgesi Ömerli Mah. Hakkı İleri Cad.
Gülce Sk. No:22 Hadımköy - Arnavutköy / İSTANBUL
Tel: +90 212 485 16 15 - Fax: +90 212 771 25 79 - www.arfen.com

ARFEN ALUMINIUM COMPANY

Ergene / TEKİRDAĞ - www.arfenaluminium.com.tr

ARFEN BUILDING AND BRIDGE TECHNOLOGY

Dilovası / Kocaeli - www.arfen.com.tr
TURKEY

For information

